

1. MECHANICAL & ASSEMBLY :

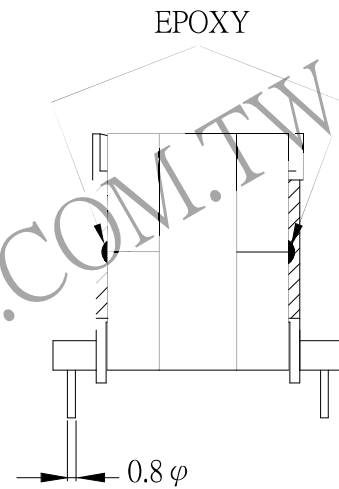
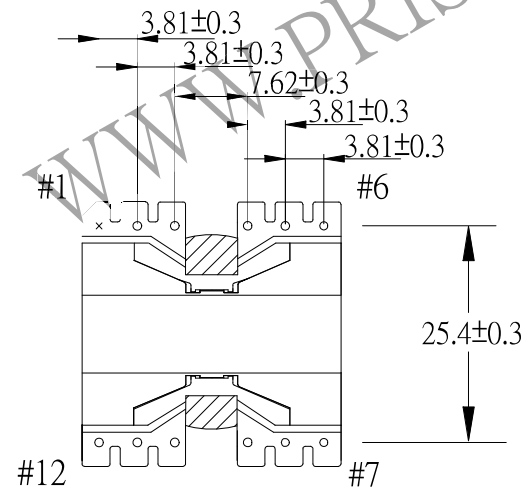
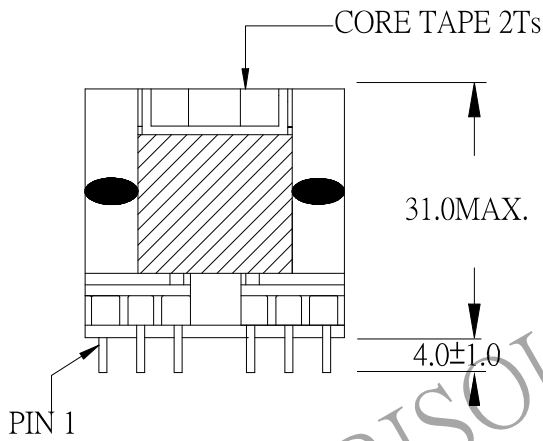
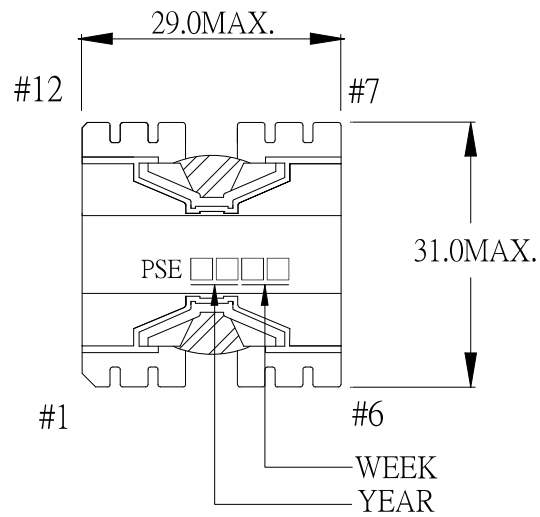

NOTE:

1. EPOXY FIXED BETWEEN CORE & CORE (TTL:4 POINTS). EPOXY FIXED TOP OF BOBBIN & CORE.(ONE POINT).
2. PIN 1 NO

UNIT : mm

REPORT BY	CHECK BY	APPROVED BY	CUSTOMER :	DATE	
			PART NO : 83P-15012	REV NO.	
			ISSUE NO :	PAGE	4 - 1

2. WINDING CONFIGURATION:

STEP	WINDING	MARGIN TAPE	START-FINISH	COPPER WIRE	TURNS	LAYER TAPE	METHOD
1	W1		2 - 4	0.10 ϕ /100C	8	2Ts	CLOSE
2	W2		10,11 - 8,9	0.65 ϕ ×2	9	2Ts	CLOSE
3	W3		3 - 5	0.10 ϕ /100C	8	2Ts	CLOSE

NOTE:

3. ELECTRICAL CHARACTERISTICS:

PIN NO.	INDUCTANCE 1.0 KHz, 0.3Vrms	LEAKAGE INDUCTANCE KHz, Vrms	VOLTAGE RATIO(V) f= 20KHz	DCR MAX AT 25°C
2,3 - 4,5	30.0uH±7.0%		0.0884Vrms±5.0%	7.0 m Ω
10,11 - 8,9			INPUT 1Vrms	20.0 m Ω

HI-POT TEST : (AT 1 mA, 2 SEC)

PRI TO SEC. 600 VAC

PRI, SEC TO CORE. 600 VAC

INSULATION RESISTANCE: (AT DC 500V)

PRI TO SEC. 100 M Ω MIN.

PRI, SEC TO CORE. 100 M Ω MIN.

REPORT BY	CHECK BY	APPROVED BY	CUSTOMER :	DATE	
			PART NO : 83P-15012	REV NO.	
			ISSUE NO :	PAGE	4 - 2

4. WINDING SEQUENCE:

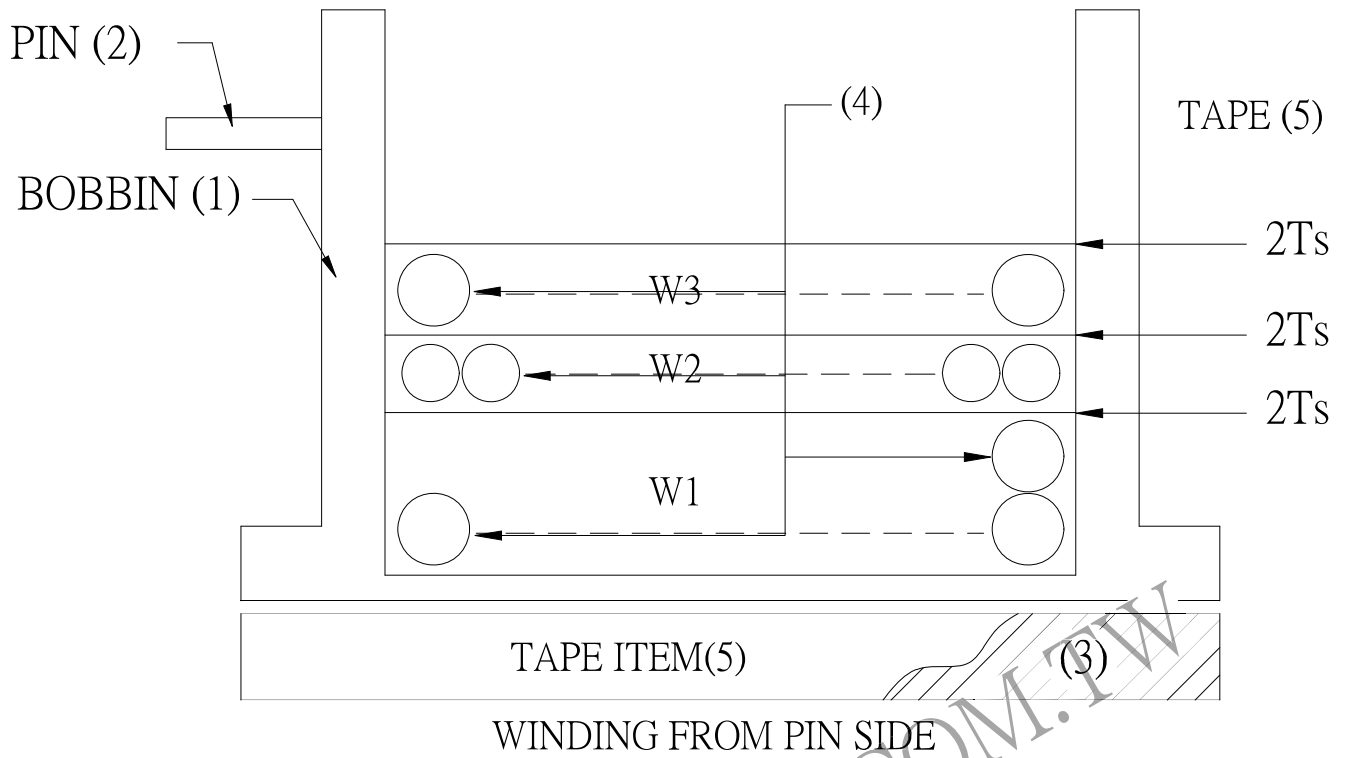

5. SCHEMATIC:

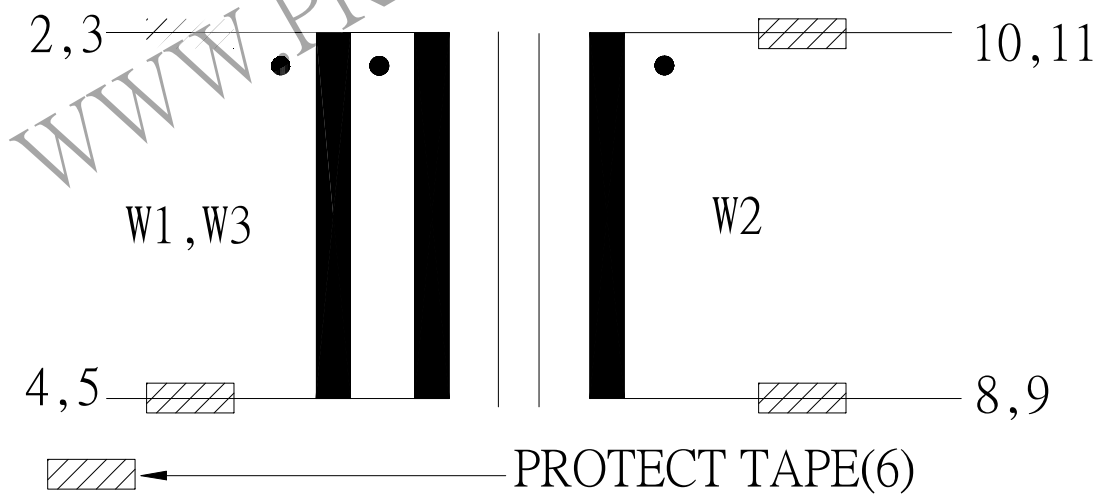

REPORT	BY	CHECK	APPROVED BY	CUSTOMER :	DATE	
				PART NO : 83P-15012	REV NO.	
				ISSUE NO :	PAGE	4 - 3