

1. MECHANICAL & ASSEMBLY :

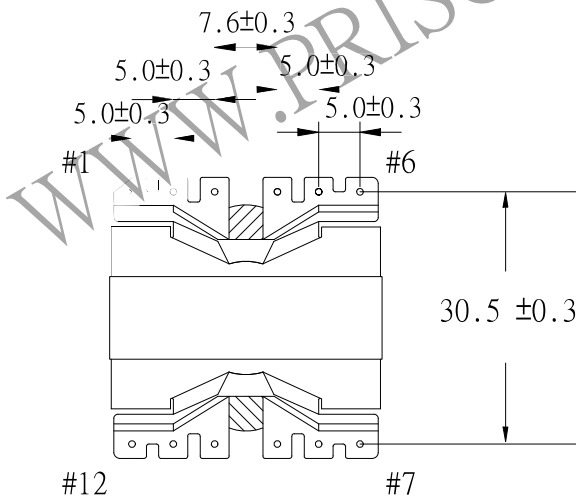
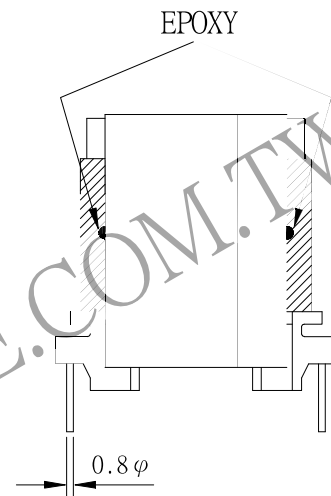
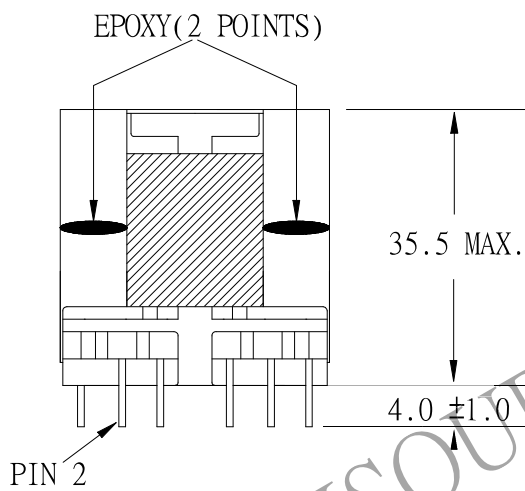
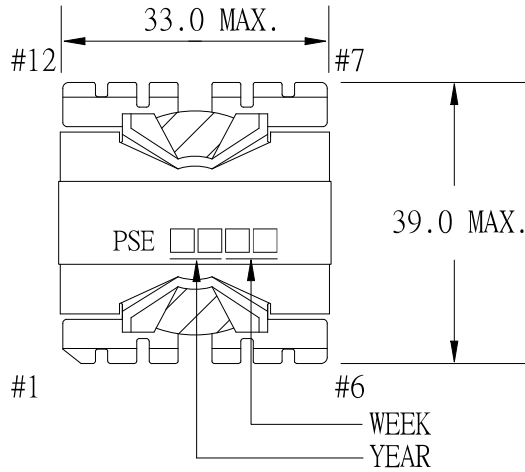

NOTE:

1. EPOXY FIXED BETWEEN CORE & CORE (TTL:4 POINTS)
2. EPOXY FIXED TOP OF BOBBIN & CORE.(ONE POINT)
3. PIN 1 NO
4. **SOLDER POINT CAN NOT BE OVER STAND OFF**

UNIT:mm

| | | | | |
|-----------|----------|-------------|---------------------|---------|
| REPORT BY | CHECK BY | APPROVED BY | CUSTOMER : | DATE |
| | | | PART NO : 83P-14003 | REV NO. |
| | | | ISSUE NO : | PAGE |
| | | | | 4 - 1 |

2. WINDING CONFIGURATION:

| STEP | WINDING | MARGIN TAPE | START-FINISH | COPPER WIRE | TURNS | LAYER TAPE | TUBE | METHOD |
|------|---------|-------------|--------------|------------------------------|-------|------------|------|--------|
| 1 | W1 | | 2 - 4 | 0.10 ϕ /100C | 10 | 2Ts | | CLOSE |
| 2 | W2 | | 10 - 8 | 0.10 ϕ /100C \times 2 | 5 | 2Ts | | CLOSE |
| 3 | W3 | | 11 - 9 | 0.10 ϕ /100C \times 2 | 5 | 2Ts | | CLOSE |
| 4 | W4 | | 3 - 5 | 0.10 ϕ /100C | 10 | 2Ts | | CLOSE |
| | | | | | | | | |
| | | | | | | | | |

NOTE:

3. ELECTRICAL CHARACTERISTICS:

| PIN NO. | INDUCTANCE 1.0 KHz, 0.3Vrms | LEAKAGE INDUCTANCE KHz, Vrms | VOLTAGE RATIO(V) F= 20KHz | DCR MAX. AT 25°C |
|-------------|--------------------------------|------------------------------------|------------------------------|---------------------|
| 2,3 - 4,5 | 180.0uH \pm 15% | | INPUT 1Vrms | 10.0m Ω |
| 10,11 - 8,9 | | | 0.5000Vrms \pm 3.0% | 3.0m Ω |
| | | | | |
| | | | | |
| | | | | |
| | | | | |
| | | | | |
| | | | | |

HI-POT TEST:(AT 1 mA, 2SEC.)

PRI TO SEC 600 VAC

PRI, SEC TO CORE 600 VAC

INSULATION RESISTANCE:(AT DC 500V)

PRI TO SEC 100 M Ω MIN.

PRI, SEC TO CORE 100 M Ω MIN.

| REPORT BY | CHECK BY | APPROVED BY | CUSTOMER : | DATE | |
|-----------|----------|-------------|---------------------|---------|-------|
| | | | PART NO : 83P-14003 | REV NO. | |
| | | | ISSUE NO : | PAGE | 4 - 2 |

4. WINDING SEQUENCE:

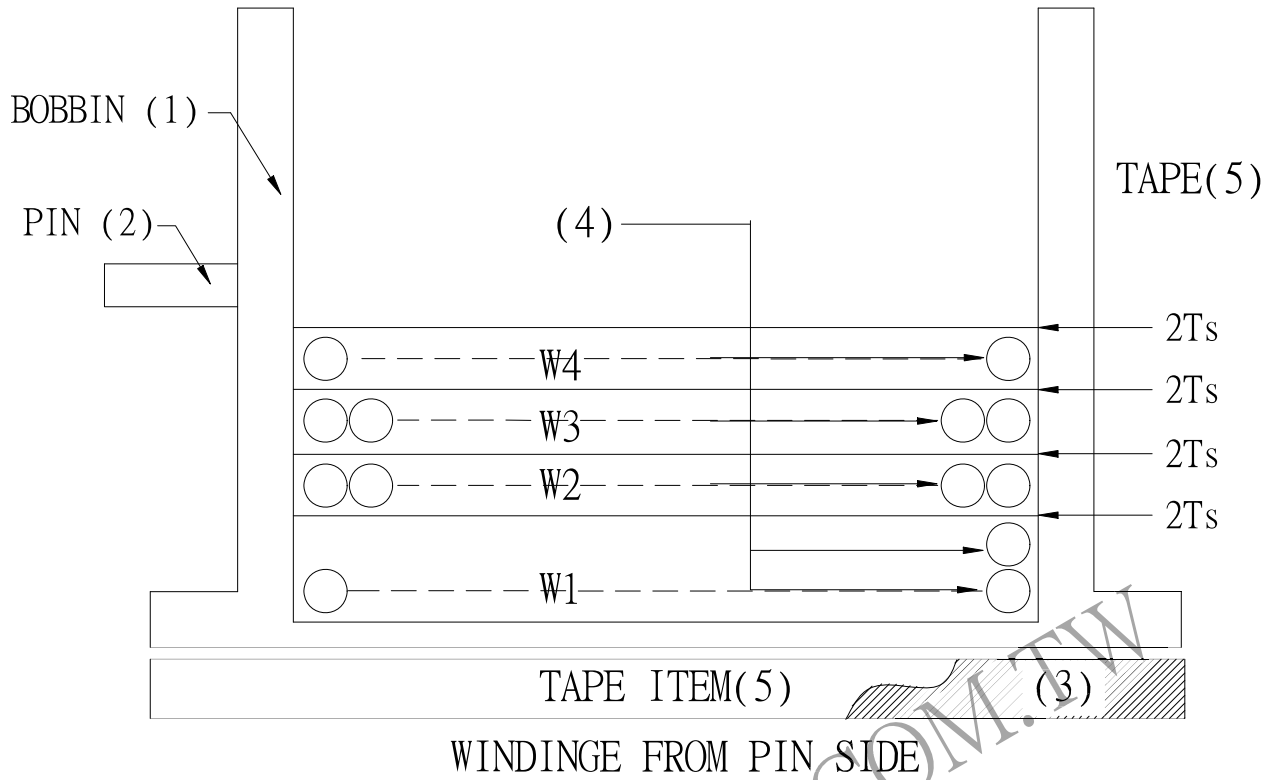

5. SCHEMATIC:

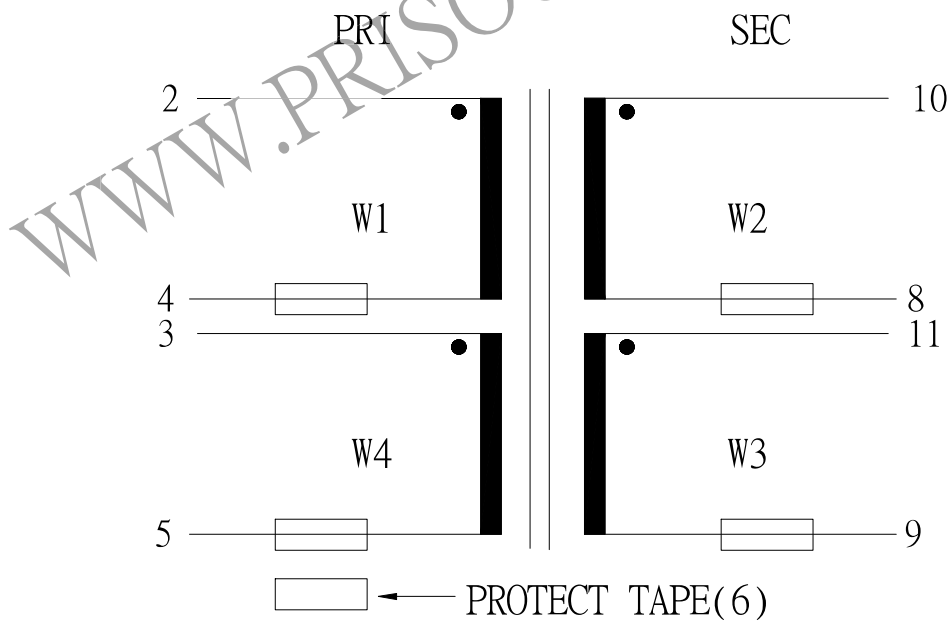

| | | | | | |
|-----------|----------|-------------|---------------------|---------|-------|
| REPORT BY | CHECK BY | APPROVED BY | CUSTOMER : | DATE | |
| | | | PART NO : 83P-14003 | REV NO. | |
| | | | ISSUE NO : | PAGE | 4 - 3 |