

1. MECHANICAL & ASSEMBLY :

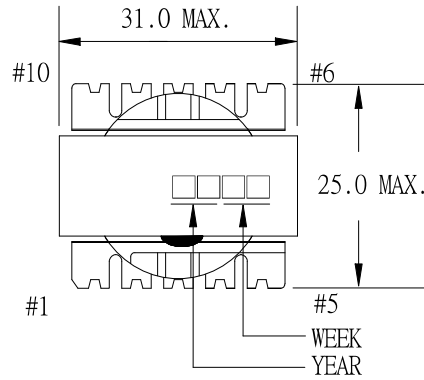

NOTE:

1. EPOXY FIXED BETWEEN CORE & CORE (TTL:4 POINTS), EPOXY FIXED TOP OF BOBBIN & CORE.(ONE POINT AT PIN1-5 SIDE).
2. PIN 6,8 NO.

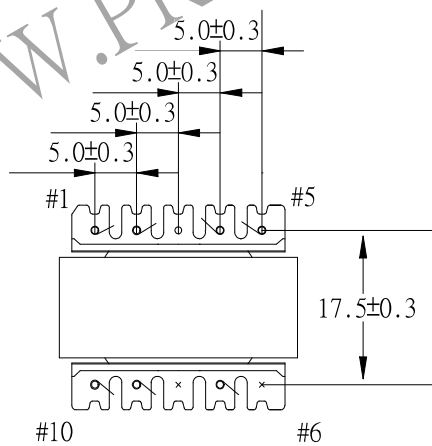
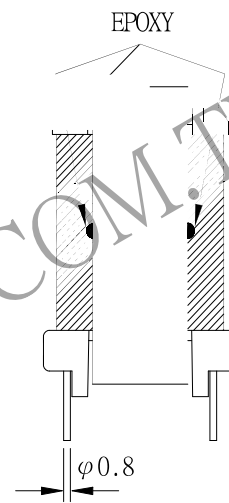
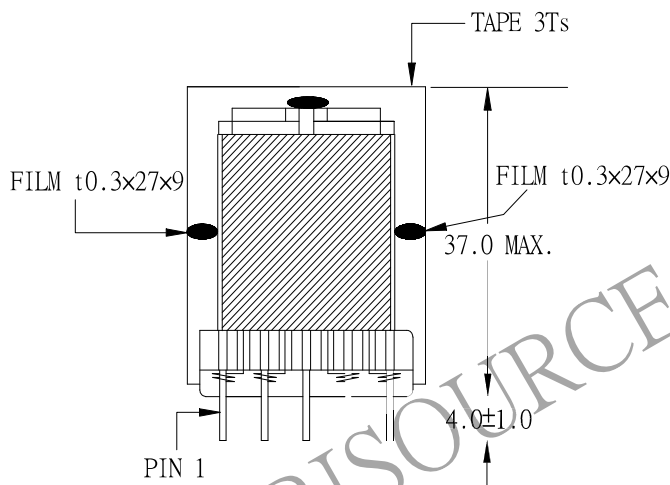

以下の治具に容易に挿入できること。

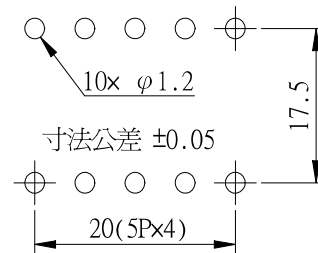

UNIT : mm

REPORT BY	CHECK BY	APPROVED BY	CUSTOMER :	DATE	
			PART NO : 81P-16036	REV NO.	
			ISSUE NO :	PAGE	4 - 1

2. WINDING CONFIGURATION:

STEP	WINDING	MARGIN TAPE	START-FINISH	COPPER WIRE	TURNS	TUBE	LAYER TAPE	METHOD
1	PM1	2.0mm/~x2Ts	2 - 4	0.55 ϕ x4	8		3Ts	CLOSE
2	S1	2.0/2.0mmx4Ts	7 - 9	TEX-E 0.35 ϕ	75		1T/1T/1T	CLOSE
3	S2	2.0/2.0mmx1T	9 - 10	TEX-E 0.35 ϕ	5		3Ts	SPACE
4	PM2	2.0/2.0mmx2Ts	1 - 5	0.50 ϕ x4	8		3Ts	CLOSE

NOTE:

3. ELECTRICAL CHARACTERISTICS:

PIN NO.	INDUCTANCE 100.0 KHz, 1.0Vrms	LEAKAGE INDUCTANCE KHz, Vrms	VOLTAGE RATIO(V) F= 20KHz	DCR MAX. AT 25°C
7 - 9	1.05 mH \pm 15%		INPUT 1 Vrms	0.80 Ω
2 - 4			0.1052 Vrms \pm 4.0%	7.8 m Ω
9 - 10			0.0664 Vrms \pm 5.0%	65.5 m Ω
1 - 5			0.1052 Vrms \pm 4.0%	14.0 m Ω

HI-POT TEST:(AT 1mA,2 SEC)

PRI. TO SEC. 3600 VAC
 PRI. TO CORE. 3600 VAC

INSULATION RESISTANCE:(AT DC 500V)

PRI. TO SEC. 100 M Ω MIN.
 PRI. TO CORE. 100 M Ω MIN.

LY(7 - 9) 1200Vo

REPORT BY	CHECK BY	APPROVED BY	CUSTOMER :	DATE
			PART NO : 81P-16036	REV NO.
			ISSUE NO :	PAGE 4 - 2

4. WINDING SEQUENCE:

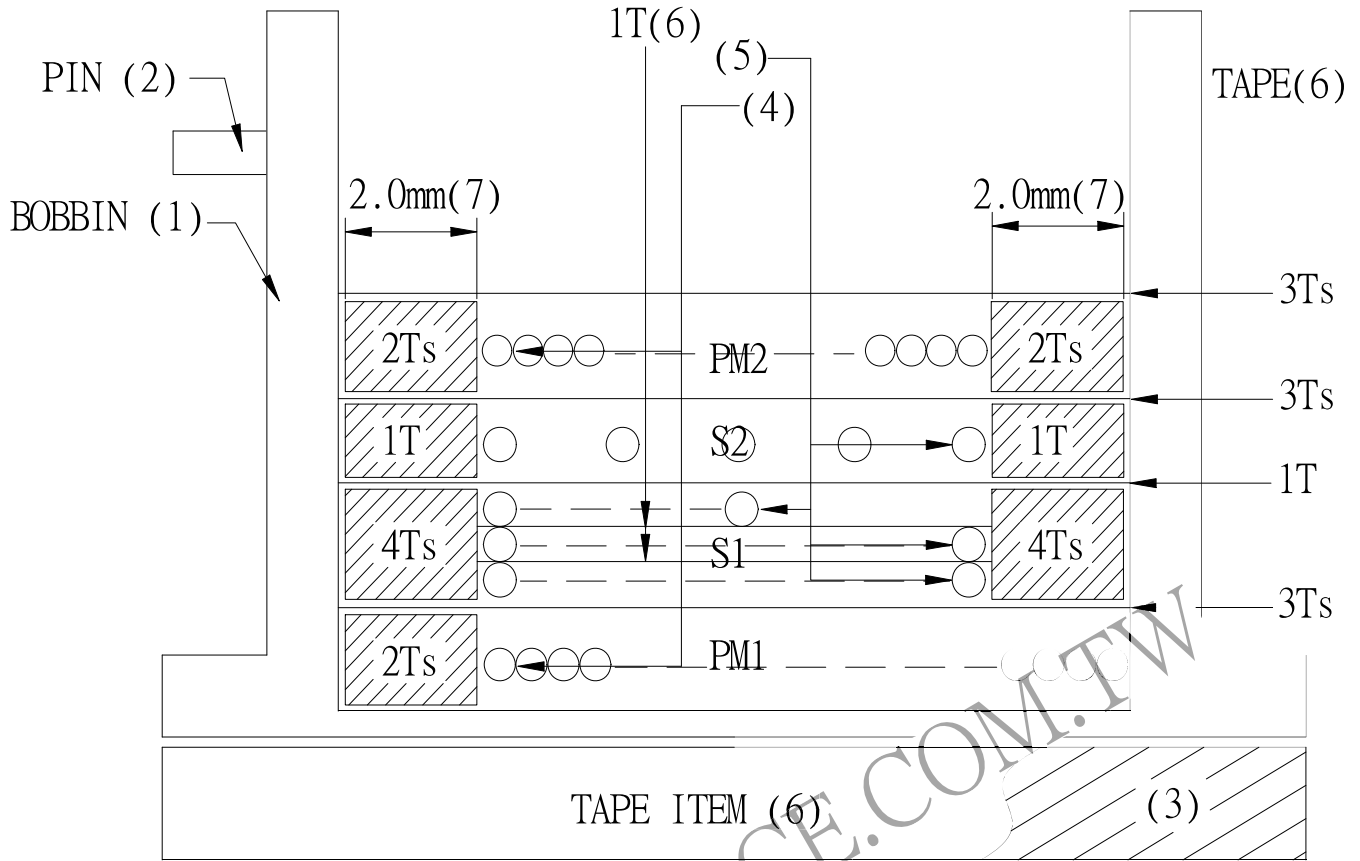

WINDING FROM PIN SIDE

5. SCHEMATIC:

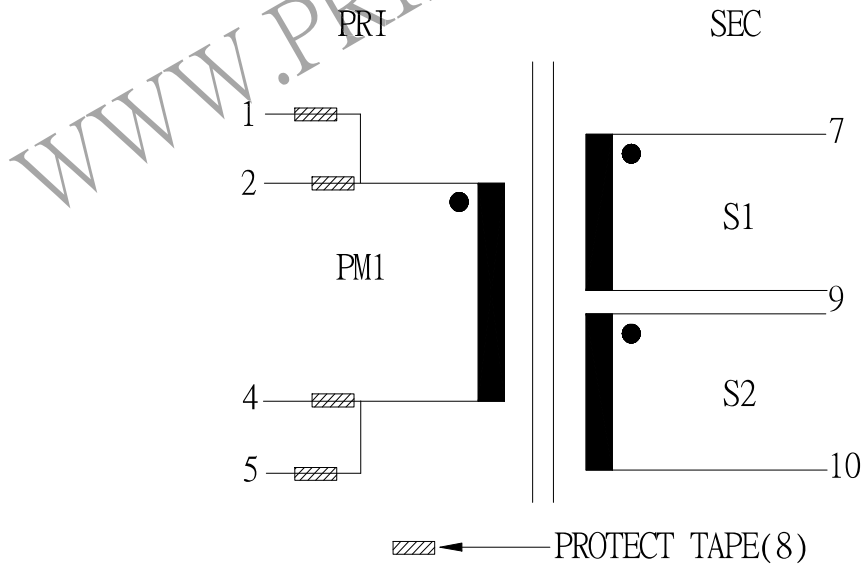

REPORT BY	CHECK BY	APPROVED BY	CUSTOMER :	DATE
			PART NO : 81P-16036	REV NO.
			ISSUE NO :	PAGE 4 - 3