

1. MECHANICAL & ASSEMBLY :

NOTE:

1. EPOXY FIXED BETWEEN CORE & CORE (TTL:4 POINTS).
2. PIN 4,11 NO.
3. ADD ONE DROPS OF GLUE INSIDE OF THE CORE TOP.
4. 飛線焊錫后需互絞 2-3 回

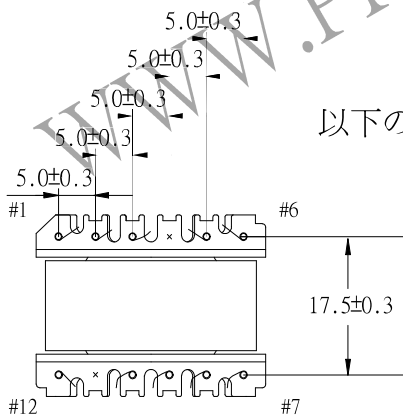
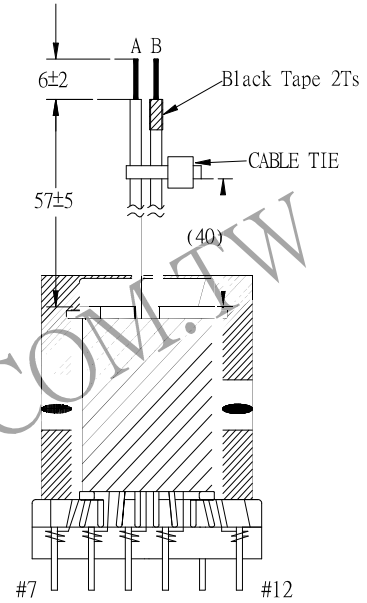
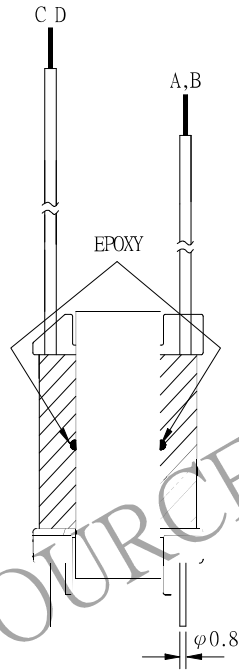
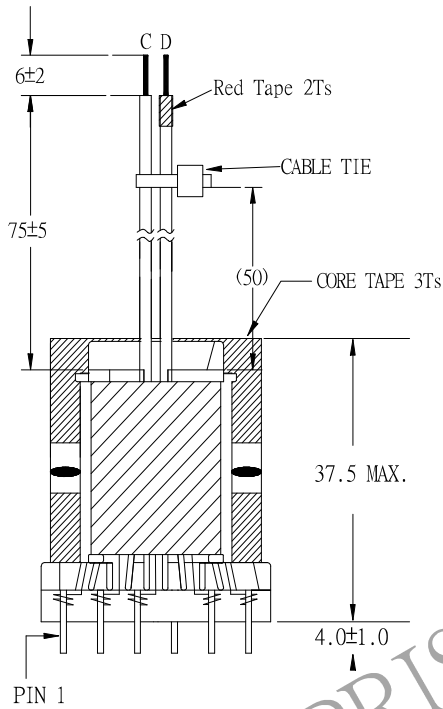
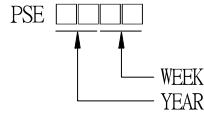
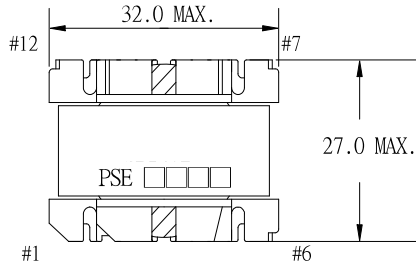

以下の治具に容易に挿入できること。

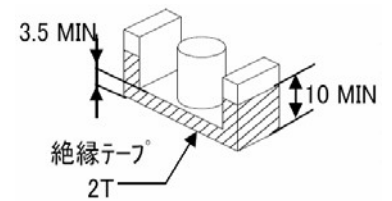
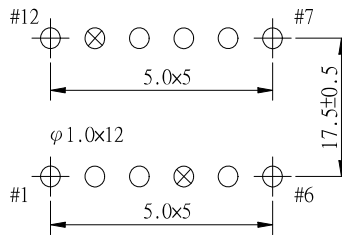

U型膠布上下鐵芯各 2PC

UNIT:mm

REPORT	BY	CHECK	BY	APPROVED	BY	CUSTOMER :	DATE
						PART NO : 81P-16032	REV NO.
						ISSUE NO :	PAGE
							4 - 1

2. WINDING CONFIGURATION :

STEP	WINDING	MARGIN TAPE	START-FINISH	COPPER WIRE	TURNS	LAYER TAPE	TUBE	METHOD
1	NP1	1.5mm/1.5mm×2Ts	1 - 2	TEX-E 0.23φ	80	1T/2Ts		CLOSE
2	NS1	3.5mm/3.5mm×1T	B - A	0.45φ	10	1T	1.0φ	SPACE
3	NS2	3.5mm/3.5mm×1T	D - C	0.45φ	15	2Ts	1.0φ	SPACE
4	NP2	~/1.5mm×1T	6 - 12	TEX-E 0.40φ	18.5	1T		CLOSE
5	NP3	1.5mm/~×1T	12 - 5	TEX-E 0.40φ	2.5	1T		CLOSE
6	NP4	1.5mm/1.5mm×1T	9 - 10	TEX-E 0.2φ×2	20	1T		CLOSE
7	NP5	1.5mm/1.5mm×1T	7 - 8	TEX-E 0.2φ×2	20	1T		CLOSE
8	NP1'	1.5mm/1.5mm×1T	2 - 3	TEX-E 0.23φ	38	2Ts		CLOSE

NOTE:

3. ELECTRICAL CHARACTERISTICS :

PIN NO.	INDUCTANCE 1.0 KHz, 1.0Vrms	LEAKAGE INDUCTANCE KHz, Vrms	VOLTAGE RATIO(V) F= 20KHz INPUT 1Vrms	DCR MAX. AT 25°C
1 - 3	1350uH±15%			3.0 Ω
B - A			0.0825rms±5.0%	97.5 mΩ
D - C			0.1256Vrms±4.0%	134.5 mΩ
6 - 12			0.1527Vrms±4.0%	180.0mΩ
12 - 5			0.0220Vrms±7.0%	33.5mΩ
9 - 10			0.1719Vrms±4.0%	0.40 Ω
7 - 8			0.1729Vrms±4.0%	0.42 Ω
1 - 2			0.6689Vrms±3.0%	1.75 Ω
2 - 3			0.3310Vrms±4.0%	1.32 Ω

HI-POT TEST:(AT 1 mA, 2SEC.)

NP. TO NS. 3600 VAC
NPS TO CORE 3600 VAC

INSULATION RESISTANCE:(AT DC 500V)

NP. TO NS.. 100 MΩ MIN.
NPS TO CORE 100 MΩ MIN.

LY(1-3) 1200Vo

REPORT BY	CHECK BY	APPROVED BY	CUSTOMER :	DATE	
			PART NO : 81P-16032	REV NO.	
			ISSUE NO :	PAGE	4 - 2

4. WINDING SEQUENCE:

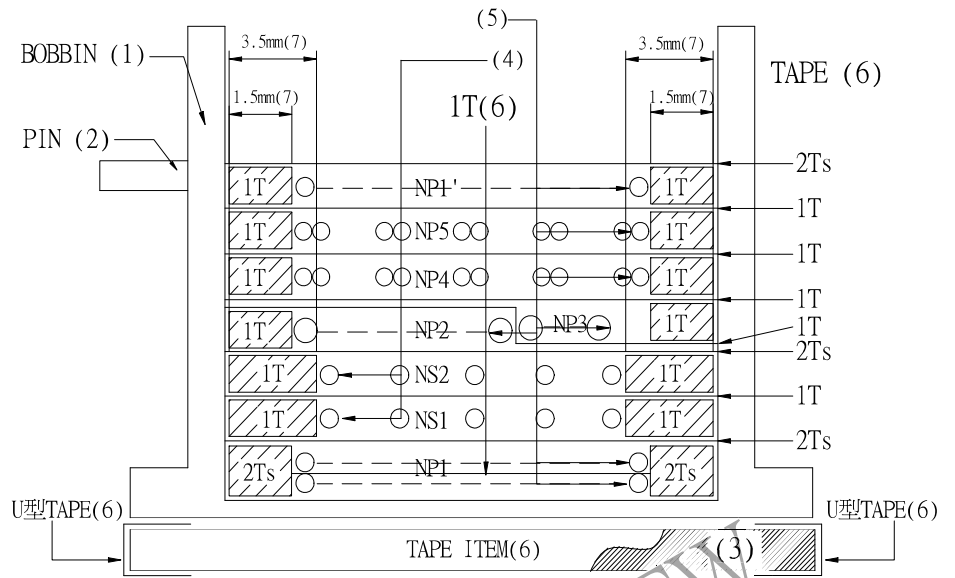
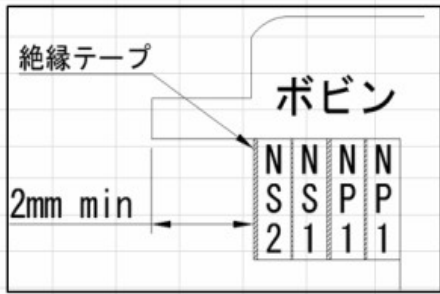

5. SCHEMATIC:

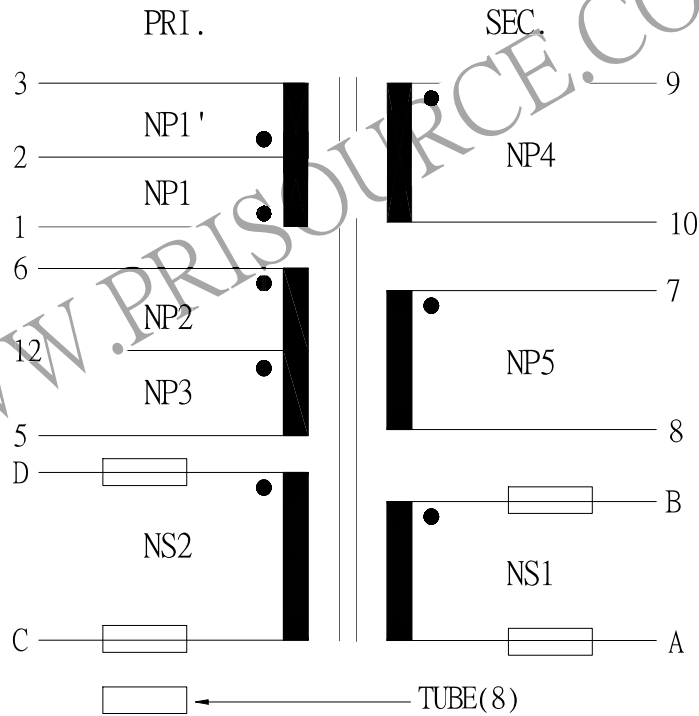

REPORT	BY	CHECK	BY	APPROVED	BY	CUSTOMER :	DATE
						PART NO : 81P-16032	REV NO.
						ISSUE NO :	PAGE
							4 - 3