

1. MECHANICAL & ASSEMBLY :

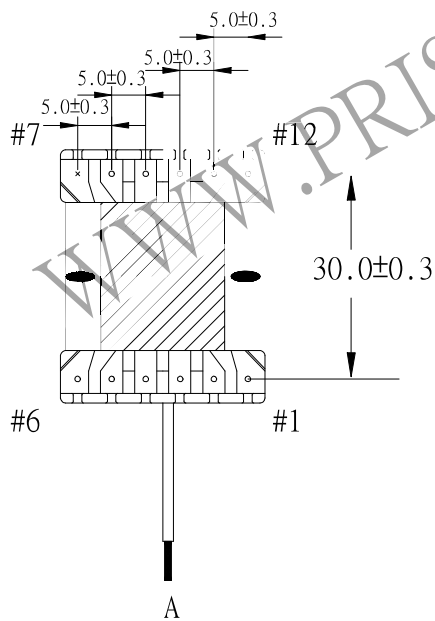
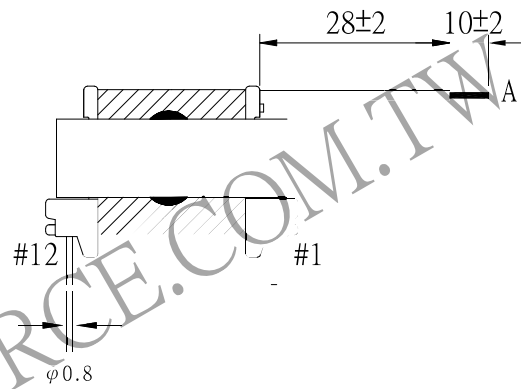
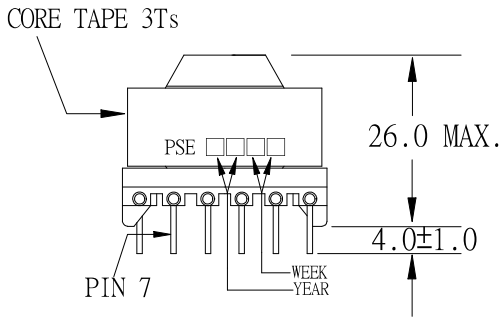
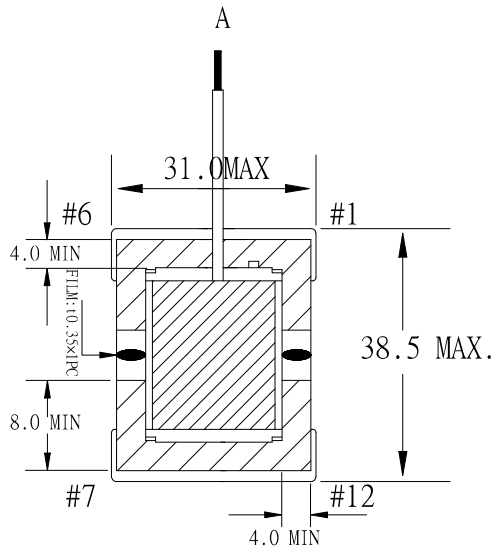

NOTE:

1. EPOXY FIXED BETWEEN CORE & CORE (TTL:4 POINTS), EPOXY FIXED TOP OF BOBBIN & CORE.(ONE POINT AT PIN 1-6 SIDE).
2. PIN 7 NO.

UNIT : m/ m

REPORT BY	CHECK BY	APPROVED BY	CUSTOMER :	DATE	
			PART NO : 81P-12007	REV NO.	
			ISSUE NO :	PAGE	4 - 1

2. WINDING CONFIGURATION :

STEP	WINDING	MARGIN TAPE	START-FINISH	COPPER WIRE	TURN	LAYER TAPE	METHOD	TUBE
1	PM1	3.0/3.0mm×1T	11 - 10	0.40φ	35	3Ts	CLOSE	
2	S1	5.0/5.0mm×2Ts	3 - 1,2	TEX-E 0.45φ×4	4	1T	CLOSE	
3	S2	4.0/4.0mm×2Ts	6 - A	TEX-E 0.60φ	15.5	1T	CLOSE	
4	S3	4.0/4.0mm×2Ts	5 - 4	TEX-E 0.50φ	16	3Ts	CLOSE	
5	PM2	3.0/3.0mm×3Ts	10 - 12	0.40φ	45	1T/1T	CLOSE/SPACE	
6	PVCC	3.0/3.0mm×1T	8 - 9	0.40φ	16	3Ts	SPACE	

NOTE:

3. ELECTRICAL CHARACTERISTICS :

PIN NO.	INDUCTANCE 100 KHz, 0.3V _{rms}	LEAKAGE INDUCTANCE KHz, V _{rms}	VOLTAGE RATIO(V) f= 20KHz	DCR MAX. AT 25°C
11 - 12	1200.0uH±25%		INPUT 1V _{rms}	
11 - 10			0.4339V _{rms} ±4.0%	0.24Ω
10 - 12			0.5658V _{rms} ±3.0%	0.46Ω
1,2 - 3			0.0493V _{rms} ±5.0%	8.0 mΩ
A - 6			0.1929V _{rms} ±4.0%	62.0mΩ
4 - 5			0.1999V _{rms} ±4.0%	100.0mΩ
8 - 9			0.2003V _{rms} ±4.0%	185.0mΩ

HI-POT TEST : (AT 1 mA, 2 SEC)

PRI	TO	SEC	4800 VAC
PRI	TO	CORE	1800 VAC

INSULATION RESISTANCE: (AT DC 500V)

PRI	TO	SEC.	100 MΩ MIN.
PRI	TO	CORE.	100 MΩ MIN.

REPORT	BY	CHECK	BY	APPROVED	CUSTOMER :	DATE	
					PART NO : 81P-12007	REV NO.	
					ISSUE NO :	PAGE	4 - 2

4. WINDING SEQUENCE:

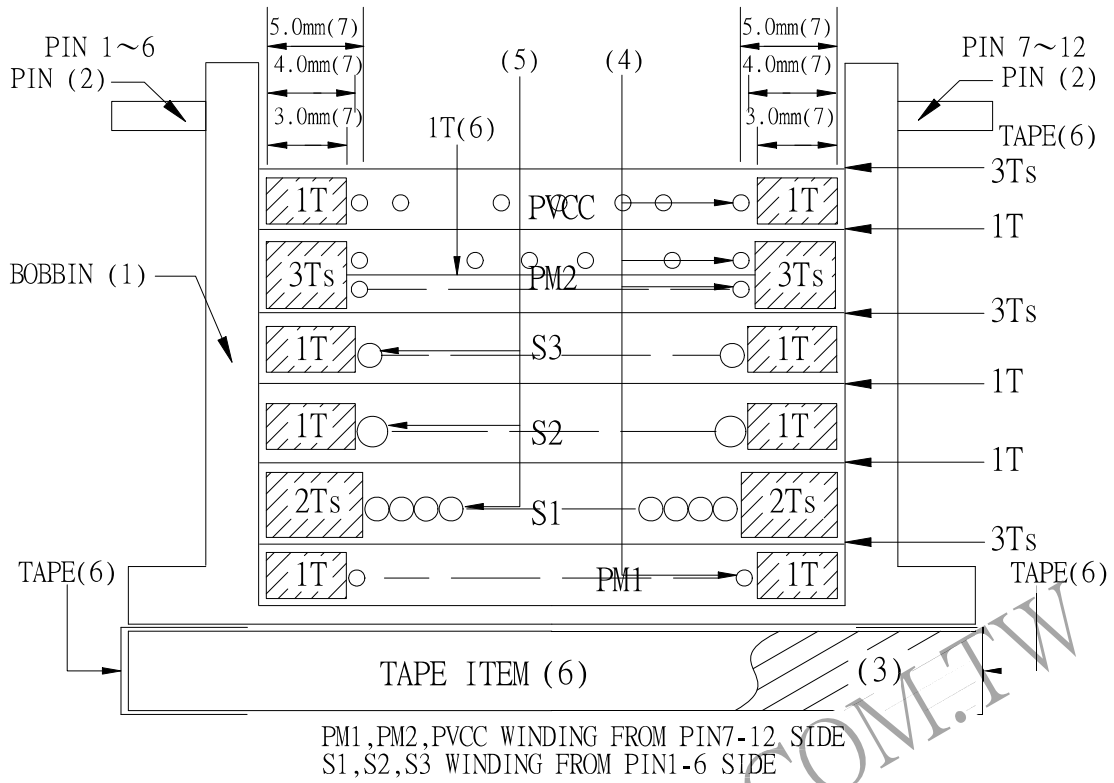

5. SCHEMATIC:

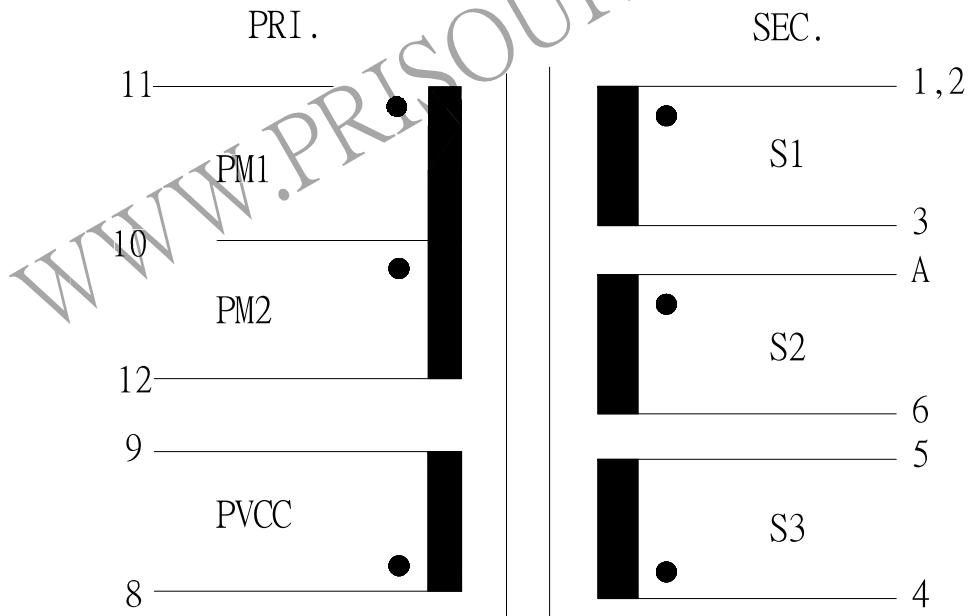

REPORT BY	CHECK BY	APPROVED BY	CUSTOMER :	DATE
			PART NO : 81P-12007	REV NO.
			ISSUE NO :	PAGE 4 - 3