

1. MECHANICAL & ASSEMBLY :

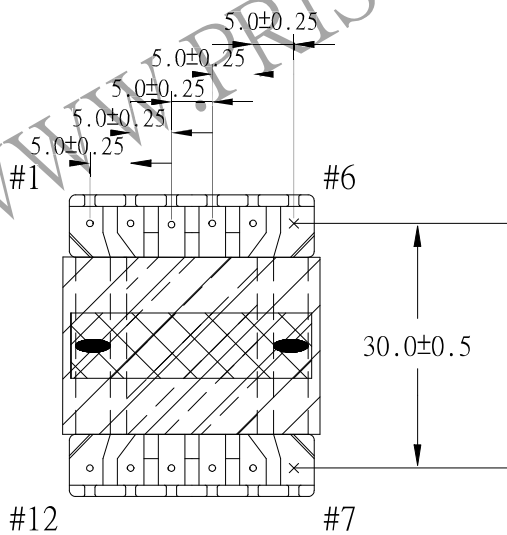
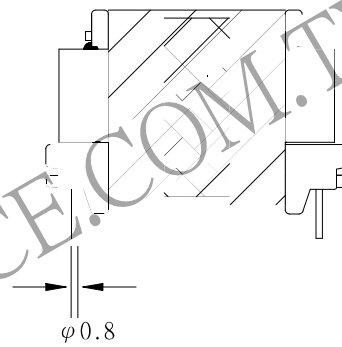
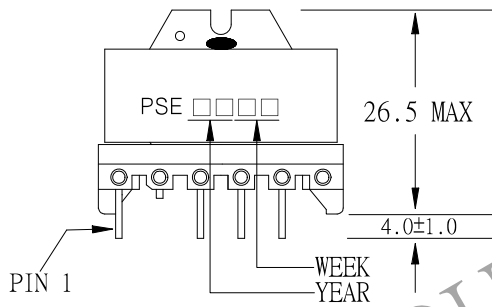
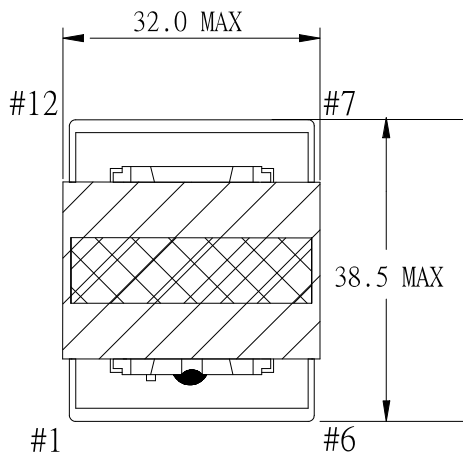

NOTE:

1. EPOXY FIXED BETWEEN CORE & CORE (TTL:4 POINTS)
2. EPOXY FIXED TOP OF BOBBIN & CORE.(ONE POINT AT PIN1-6 SIDE).
3. PIN,6,7NO
4. PIN 2 CUT SHORTER CAN NOT OVER STOPPER

UNIT : m/m

REPORT BY	CHECK BY	APPROVED BY	CUSTOMER :	DATE	
			PART NO : 66P-14002	REV NO.	
			ISSUE NO :	PAGE	4-1

2. WINDING CONFIGURATION :

STEP	WINDING	MARGIN TAPE	START-FINISH	COPPER WIRE	TURNS	LAYER TAPE	TUBE	METHOD
1	W1	3.0mm/3.0mm×2Ts	2 - 1	0.55φ	25	1T	AWG#20	CLOSE
2	SCREEN 1	3.0mm/3.0mm×1T	5 -	t0.05 x15	1	3Ts	AWG#20	Center
3	W2	3.0mm/3.0mm×2Ts	10 - 12	0.45φ x5	6	1T	AWG#14	CLOSE
4	W3	~ / 3.0mm x2Ts	9 - 8	0.45φ x7	3	1PC	AWG#14	CLOSE
5	W4	3.0mm/~ x2Ts	5 - 4	TEX-E 0.20φ	6	1T	AWG#20	CLOSE
6	W5	3.0mm/3.0mm×2Ts	11 - 10	0.45φ x5	6	3Ts	AWG#14	CLOSE
7	SCREEN 2	3.0mm/3.0mm×1T	5 -	t0.05 x15	1	1T	AWG#20	Center
8	W6	3.0mm/3.0mm×2Ts	3 - 2	0.55φ	25	3Ts	AWG#20	CLOSE
9	SCREEN 3		5 -	t0.05 x10	1	2Ts	AWG#20	

NOTE : SCREEN1~ 3 EACH TERMINATE 0.3φ WIRE TO THE PIN 5

3. ELECTRICAL CHARACTERISTICS :

PIN NO.	INDUCTANCE 100.0 KHz, 1.0Vrms	LEAKAGE INDUCTANCE KHz, Vrms	VOLTAGE RATIO(V) F= 20KHz	DCR MAX. AT 20°C
3 - 1	530.0uH ±10%		INPUT 1.0 Vrms	0.25 Ω
10 - 12			0.1190Vrms±4.0%	9.0 mΩ
9 - 8			0.0597Vrms±5.0%	4.5 mΩ
5 - 4			0.1208Vrms±4.0%	0.22 Ω
11 - 10			0.1205Vrms±4.0%	11.0 mΩ
3 - 2			0.5087Vrms±3.0%	0.15 Ω
2 - 1			0.4912Vrms±4.0%	94.0 mΩ

HI-POT TEST :(AT 1 mA, 5 SEC.)

PRI	TO	SEC	3500 VAC
PRI	TO	CORE	1800 VAC
SEC	TO	CORE	1800 VAC
PRI	TO	PRI	500 VAC
SEC	TO	SEC	500 VAC

INSULATION RESISTANCE:(AT DC 500V)

PRI	TO	SEC	100 MΩ MIN.
PRI	TO	CORE	100 MΩ MIN.
SEC	TO	CORE	100 MΩ MIN.

REPORT BY	CHECK BY	APPROVED BY	CUSTOMER :	DATE	
			PART NO : 66P-14002	REV NO.	
			ISSUE NO :	PAGE	4-2

4. WINDING SEQUENCE

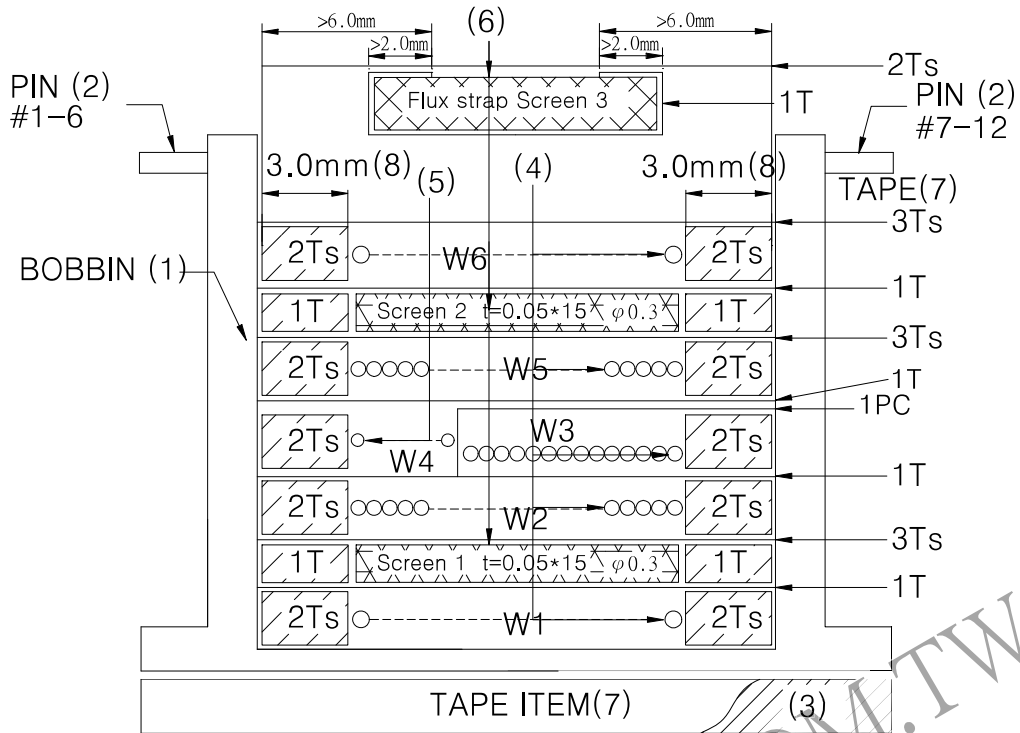

5. SCHEMATIC :

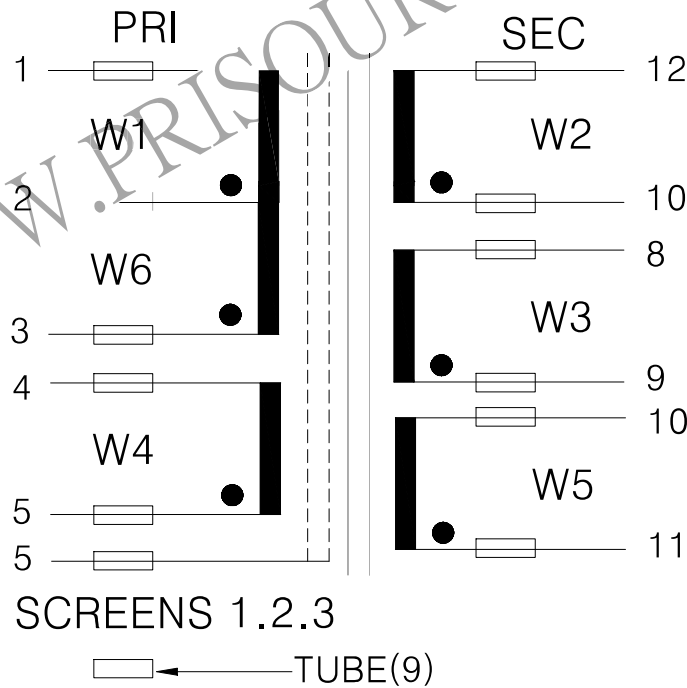

REPORT	BY	CHECK	BY	APPROVED	CUSTOMER :	DATE	
					PART NO : 66P-14002	REV NO.	
					ISSUE NO :	PAGE	4-3