

1. MECHANICAL & ASSEMBLY :

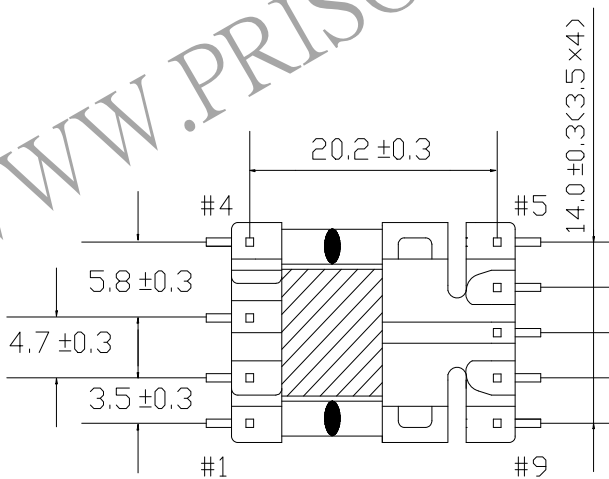
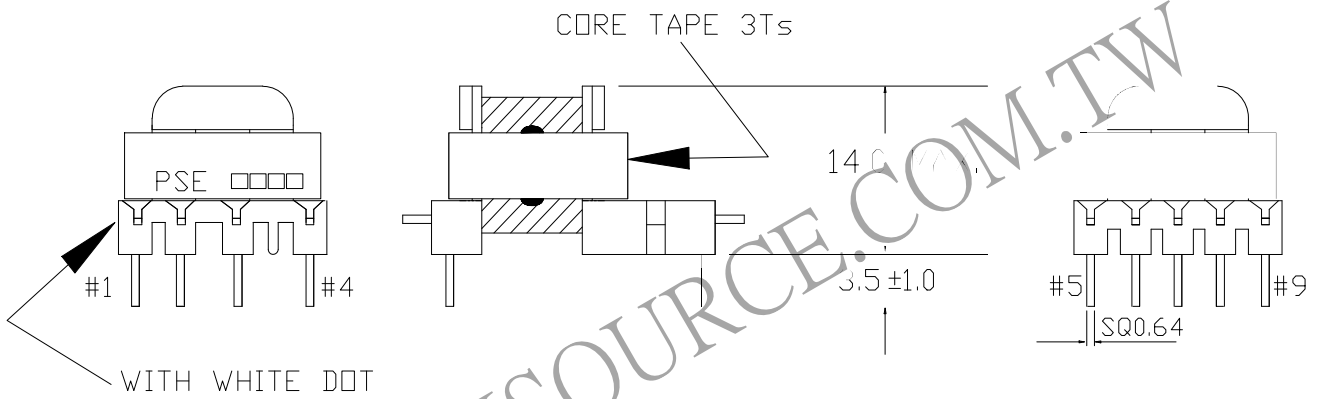
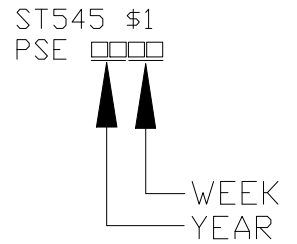
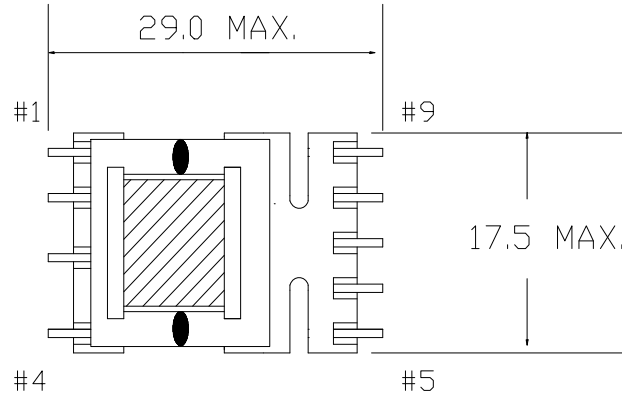

NOTE:

1. EPOXY FIXED BETWEEN CORE & CORE (TTL:4 POINTS). EPOXY FIXED OF BOBBIN & CORE.(ONE POINT AT PIN1-4 SIDE).
2. PIN 1 WITH WHITE DOT

NIT:mm

REPORT BY	CHECK BY	APPROVED BY	CUSTOMER :	DATE
			PART NO : 54P-17056	REV NO.
			ISSUE NO :	PAGE
				4 - 1

2. WINDING CONFIGURATION :

STEP	WINDING	MARGIN TAPE	START-FINISH	COPPER WIRE	TURNS	LAYER TAPE	TUBE	METHOD
1						1T		
2	P3	3.5mm/1.0mm×1T	5 - 9	0.16φ	2	3Ts		SPACE
3	P1	3.5mm/1.0mm×3Ts	6 - 7	0.16φ	20	4Ts	#28	BIFILAR, CLOSE
4	P2		7 - 8	0.16φ	20			
5	S1	1.0mm/3.5mm×1T	3 - 2	0.16φ	9	2Ts		CLOSE
6	S2	1.0mm/3.5mm×1T	2 - 1	0.16φ	9	2Ts	#28	CLOSE

NOTE:

3. ELECTRICAL CHARACTERISTICS :

PIN NO.	INDUCTANCE 1.0 KHz, 1.0Vrms	LEAKAGE INDUCTANCE KHz, Vrms	VOLTAGE RATIO(V) F= 20KHz	DCR MAX. AT 25°C
6 - 8	400.0uH±15%		INPUT 1Vrms	1.30 Ω
5 - 9			0.0490Vrms±7.0%	85.5mΩ
6 - 7			0.5005Vrms±3.0%	0.65 Ω
7 - 8			0.4997Vrms±4.0%	0.65 Ω
3 - 2			0.2185Vrms±4.0%	0.35 Ω
2 - 1			0.2188Vrms±4.0%	0.35 Ω

HI-POT TEST :(AT 1 mA, 1 SEC.)

PRI. TO SEC. 3600 VAC
PRI,SEC TO CORE. 1800 VAC

INSULATION RESISTANCE:

PRI. TO SEC. 100 MΩ ≧ . (AT DC 1000V)
PRI,SEC TO CORE. 100 MΩ ≧ . (AT DC 500V)

REPORT BY	CHECK BY	APPROVED BY	CUSTOMER :	DATE
			PART NO : 54P-17056	REV NO.
			ISSUE NO :	PAGE 4 - 2

4. WINDING SEQUENCE:

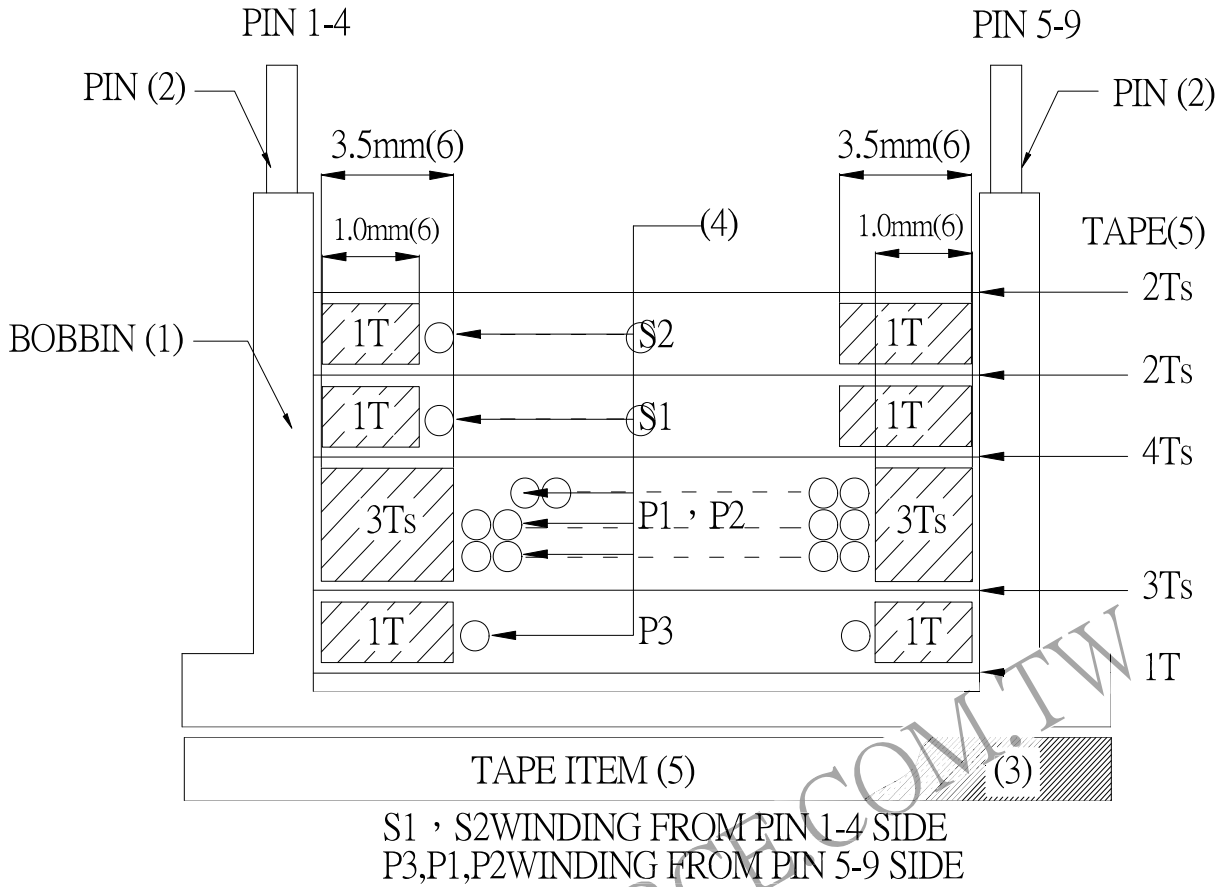

5. SCHEMATIC:

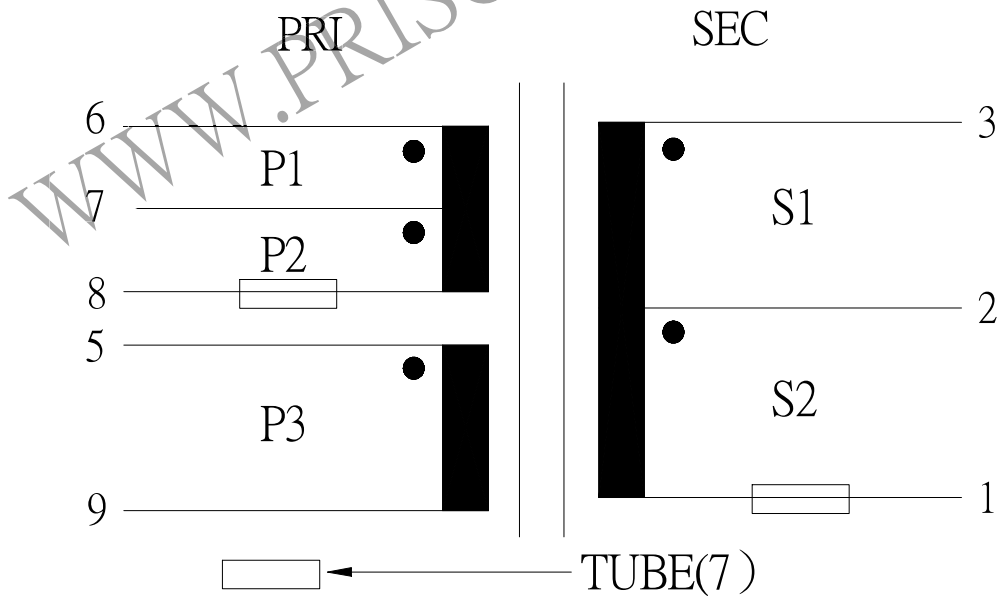

REPORT BY	CHECK BY	APPROVED BY	CUSTOMER :	DATE	
			PART NO : 54P-17056	REV NO.	
			ISSUE NO :	PAGE	4 - 3