

1. MECHANICAL & ASSEMBLY :

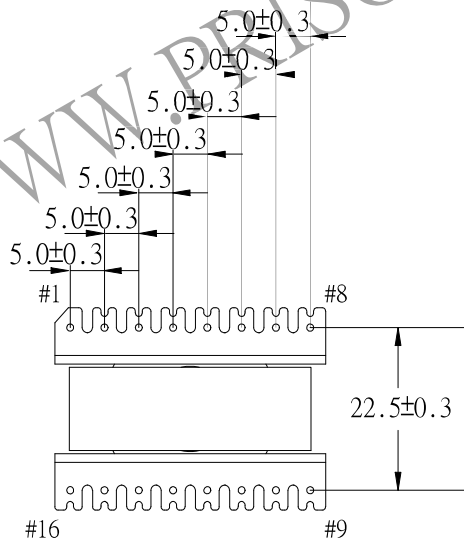
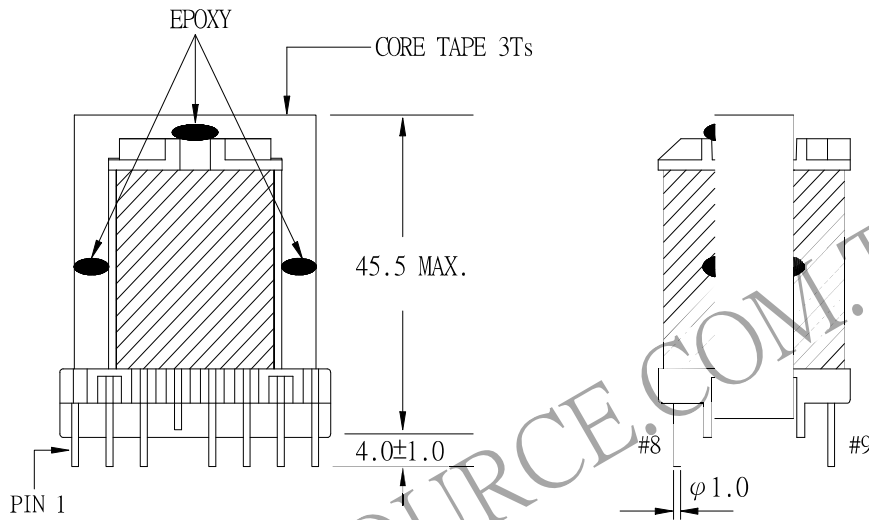
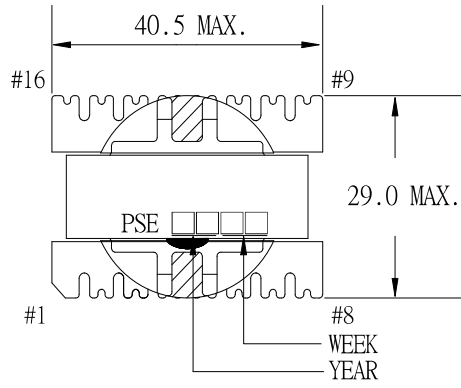

NOTE:

1. EPOXY FIXED BETWEEN CORE & CORE (TTL:4 POINTS) POXY FIXED TOP OF BOBBIN & CORE.(ONE POINT AT PIN1-8 SIDE).
2. PIN 4 CUT SHORTER AFTER SOLDERING

UNIT : m/m

REPORT BY	CHECK BY	APPROVED BY	CUSTOMER :	DATE	
			PART NO : 54P-16109	REV NO.	
			ISSUE NO :	PAGE	4 - 1

2. WINDING CONFIGURATION :

STEP	WINDING	MARGIN TAPE	START-FINISH	COPPER WIRE	TURNS	TUBE	LAYER TAPE	METHOD
1	NP1	4.0mm/4.0mm×1T	3 - 4	0.30 ϕ ×2	25	#20/#20	3Ts	SPACE
2	NS1	4.0mm/4.0mm×2Ts	13,14 - 15,16	0.10 ϕ /80C×2	3	#15/#15	3Ts	SPACE
3	NS2	4.0mm/4.0mm×2Ts	11 - 10,12	0.75 ϕ ×2	9	#15/#18	3Ts	SPACE
4	NS3	4.0mm/4.0mm×2Ts	10,12 - 9	0.75 ϕ ×2	9	#18/#15	3Ts	SPACE
5	NP2	4.0mm/4.0mm×1T	4 - 5	0.30 ϕ ×2	25	#20/#20	3Ts	SPACE
6	NG1	4.0mm/4.0mm×1T	7 - 8	0.10 ϕ	1	#26/#26	3Ts	CLOSE Center
7	NB1	4.0mm/4.0mm×1T	2 - 1	0.10 ϕ	13	#26/#26	3Ts	CLOSE Center

NOTE:

3. ELECTRICAL CHARACTERISTICS :

PIN NO.	INDUCTANCE 1.0 KHz, 1.0Vrms	LEAKAGE INDUCTANCE KHz, Vrms	VOLTAGE RATIO(V) F= 20KHz	DCR MAX. AT 25°C
3 - 5	769.0uH ±10%		INPUT 1-Vrms	0.45 Ω
3 - 4			0.4936 Vrms±4.0%	175.0 m Ω
13,14 - 15,16			0.0593 Vrms±5.0%	4.3 m Ω
11 - 10,12			0.1796 Vrms±4.0%	15.5 m Ω
10,12 - 9			0.1805 Vrms±4.0%	17.2 m Ω
4 - 5			0.5058 Vrms±3.0%	0.27 Ω
7 - 8			0.0201 Vrms±7.0%	0.32 Ω
2 - 1			0.2619 Vrms±4.0%	2.8 Ω

HI-POT TEST :(AT 1 mA ,3 SEC)

PRI.	TO	SEC.	3750 VAC
SEC.	TO	CORE	3750 VAC
PRI.	TO	CORE	3750 VAC

INSULATION RESISTANCE:(AT DC 500V)

PRI.	TO	SEC.	100 M Ω MIN.
SEC.	TO	CORE	100 M Ω MIN.
PRI.	TO	CORE	100 M Ω MIN.

REPORT BY	CHECK BY	APPROVED BY	CUSTOMER :	DATE
			PART NO : 54P-16109	REV NO.
			ISSUE NO :	PAGE
				4 - 2

4. WINDING SEQUENCE:

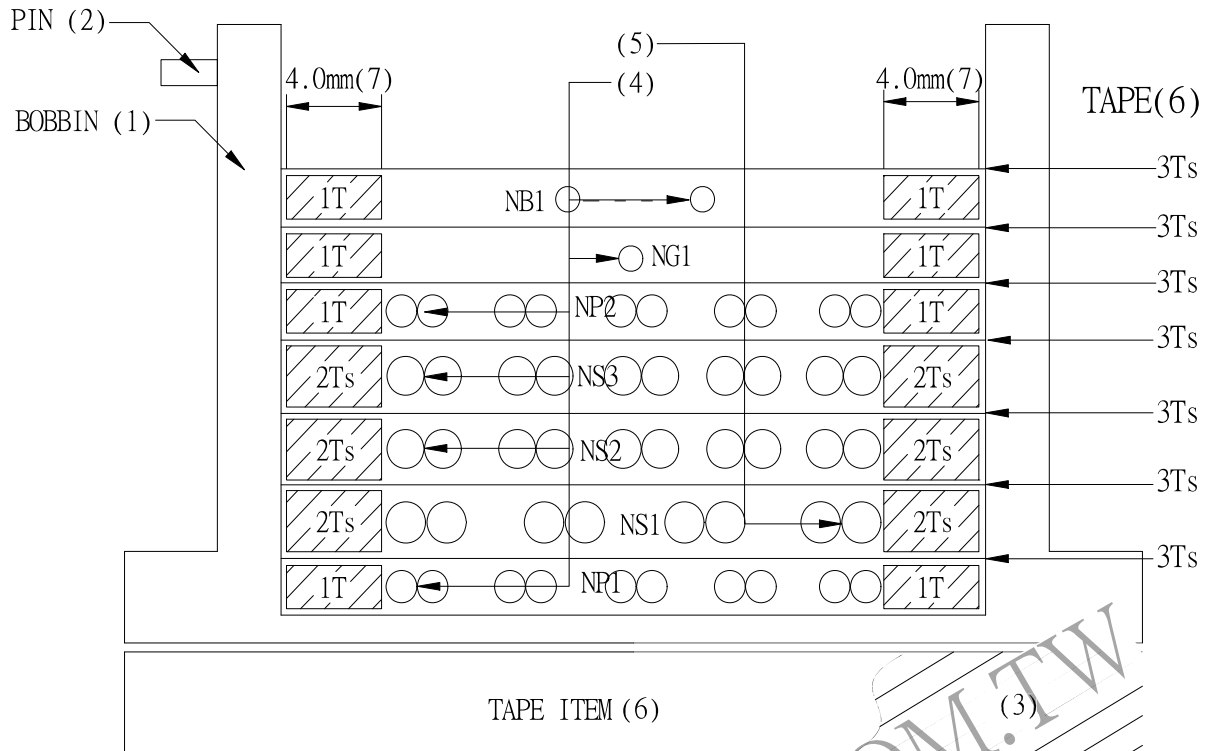

NP1, NP2, NG1, NB1 WINDING FROM PIN 1-8 SIDE
 NS1, NS2, NS3 WINDING FROM PIN 9-16 SIDE

5. SCHEMATIC:

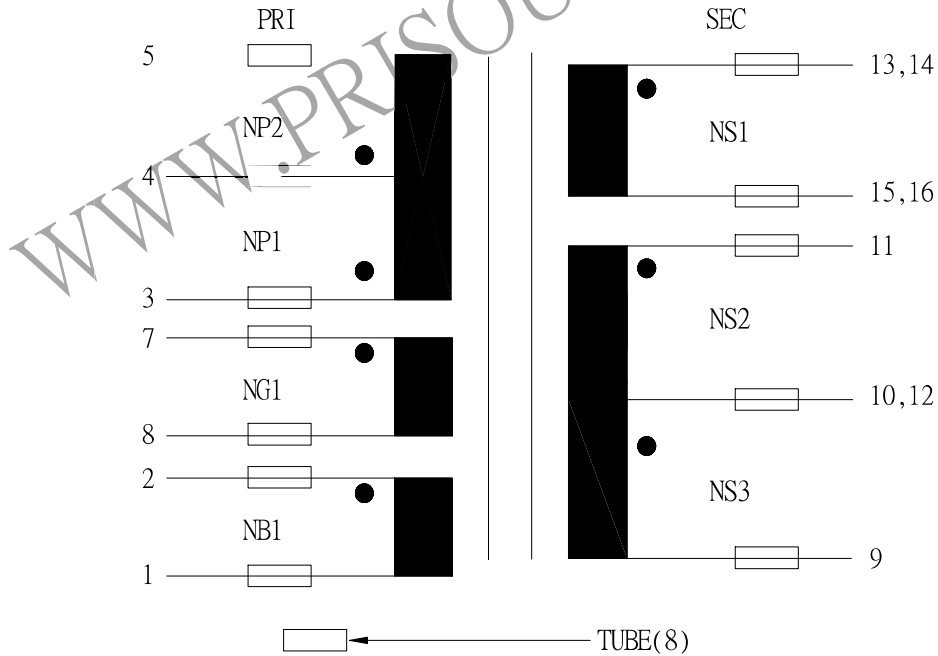

REPORT BY	CHECK BY	APPROVED BY	CUSTOMER :	DATE
			PART NO : 54P-16109	REV NO.
			ISSUE NO :	PAGE
				4 - 3