

1. MECHANICAL & ASSEMBLY :

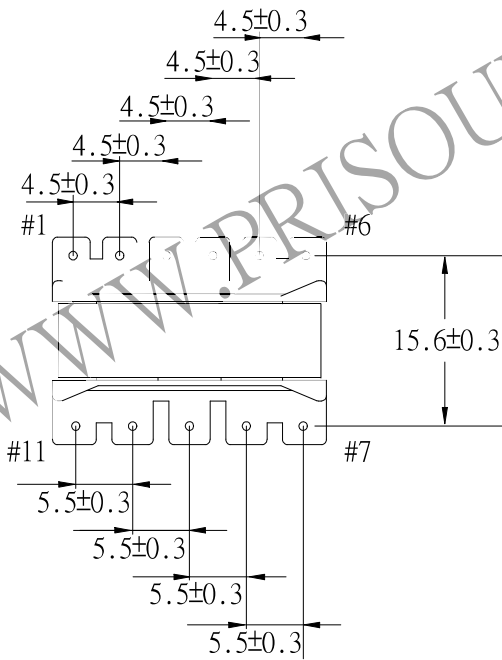
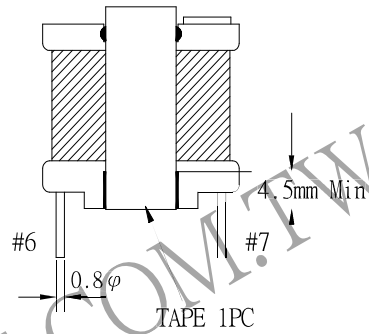
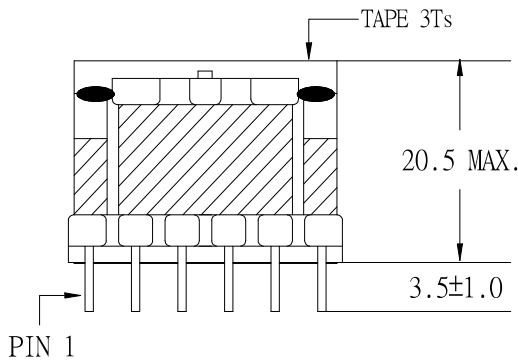
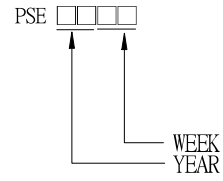
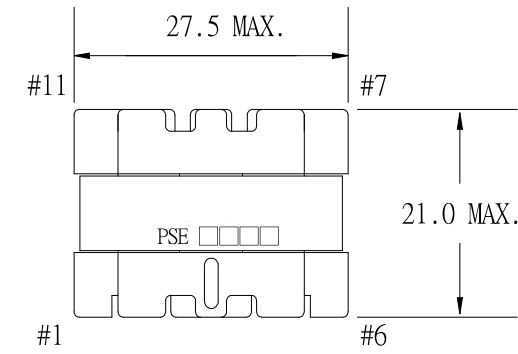

NOTE:

1. EPOXY FIXED BETWEEN CORE & CORE (TTL:4 POINTS)

UNIT : mm

REPORT BY	CHECK BY	APPROVED BY	CUSTOMER :	DATE
			PART NO : 54P-15066	REV NO.
			ISSUE NO :	PAGE
				4 - 1

2. WINDING CONFIGURATION :

STE	WINDING	MARGIN TAPE	START-FINISH	COPPER WIRE	TURNS	LAYER TAPE	TUBE	METHOD
1	NP1	~4.5mm×2Ts	1 - 2	0.22φ	41	3Ts	Φ0.6/Φ0.6	CLOSE
2	NS1		10 - 7	TEX-E 0.55φ	8	3Ts		SPACE
3	NP2	~4.5mm×2Ts	2 - 3	0.22φ	41	3Ts	Φ0.6/Φ0.6	CLOSE
4	NS2		11 - 8	TEX-E 0.55φ	8	3Ts		SPACE
5	NB2	~4.5mm×1T	5 - 4	0.18φ	15	1T	Φ0.6/Φ0.6	SPACE
6	NB1	~4.5mm×1T	4 - 6	0.18φ	35	3Ts	Φ0.6/Φ0.6	CLOSE SPACE

NOTE:

3. ELECTRICAL CHARACTERISTICS :

PIN NO.	INDUCTANCE 1.0 KHz, 1.0Vrms	LEAKAGE INDUCTANCE KHz, Vrms	VOLTAGE RATIO(V) F= 20KHz	DCR MAX. AT 25°C
1 - 3	1.50mH ±10%		INPUT 1 Vrms	1.85 Ω
1 - 2			0.4948Vrms±4.0%	0.80 Ω
10 - 7			0.0983Vrms±4.0%	31.0mΩ
11 - 8			0.0982Vrms±4.0%	38.0mΩ
5 - 4			0.1830Vrms±4.0%	0.68 Ω
4 - 6			0.4250Vrms±4.0%	1.65 Ω

HI-POT TEST :(AT 1mA, 3 SEC.)

PRI.	TO	SEC.	3750 VAC
SEC.	TO	CORE.	3750 VAC
PRI.	TO	CORE.	3750 VAC

INSULATION RESISTANCE:(AT DC 500V)

PRI.	TO	SEC.	50 MΩ MIN.
------	----	------	------------

REPORT BY	CHECK BY	APPROVED BY	CUSTOMER :	DATE
			PART NO : 54P-15066	REV NO.
			ISSUE NO :	PAGE
				4 - 2

4. WINDING SEQUENCE:

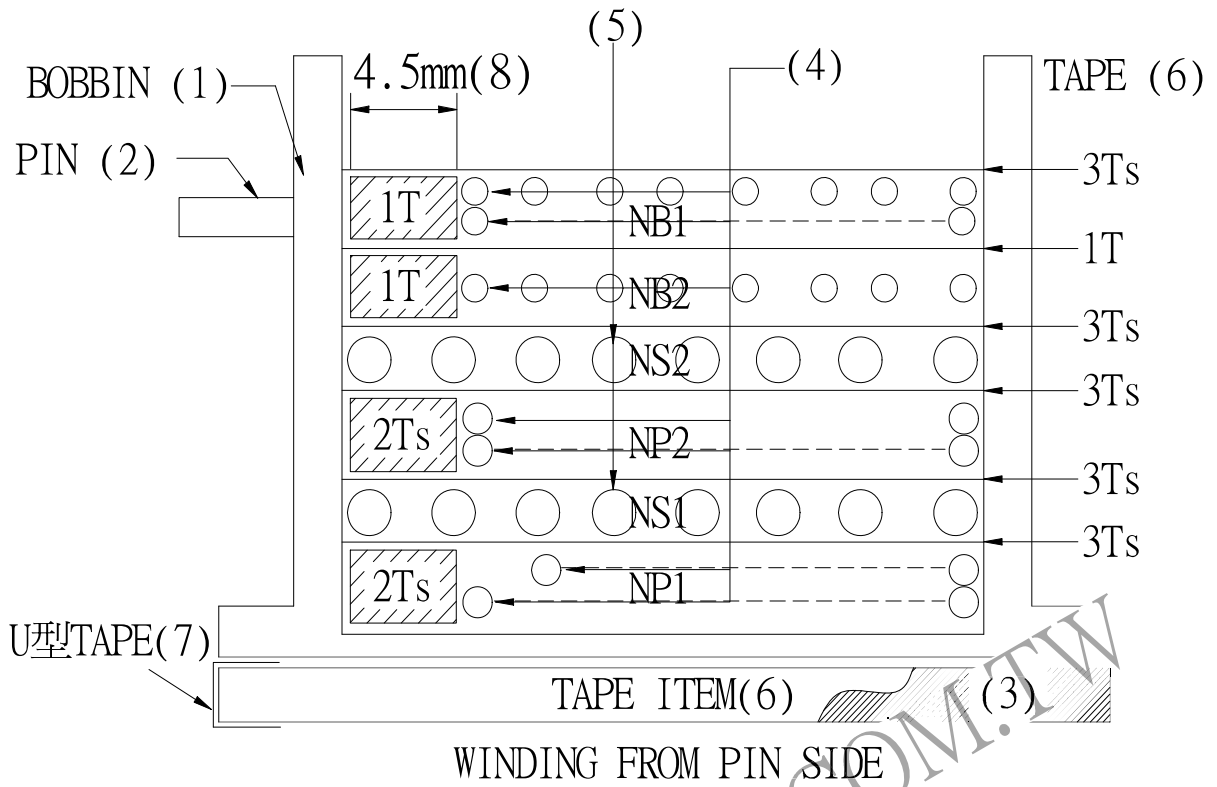

5. SCHEMATIC:

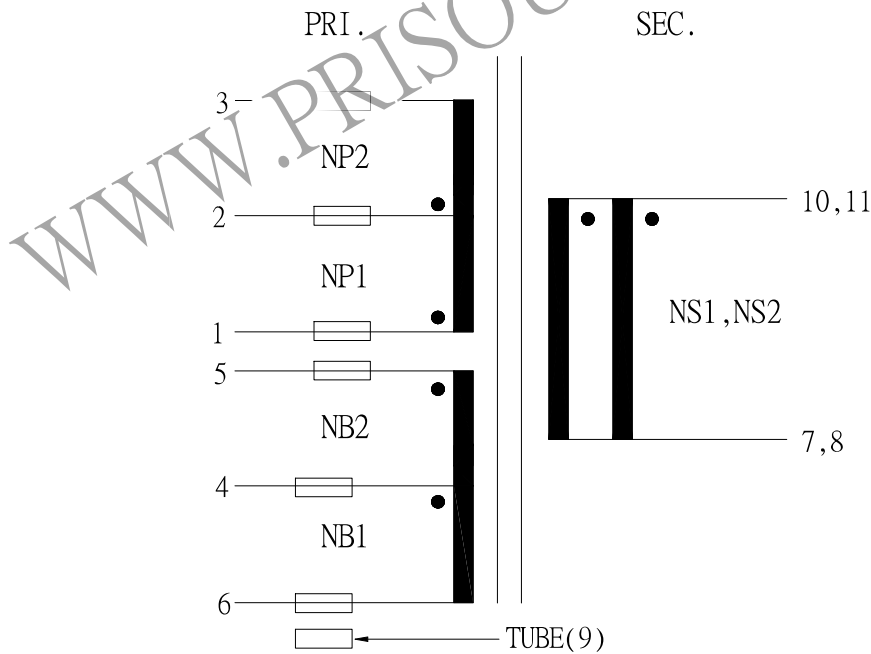

REPORT BY	CHECK BY	APPROVED BY	CUSTOMER :	DATE
			PART NO : 54P-15066	REV NO.
			ISSUE NO :	PAGE
				4 - 3