

# 1. MECHANICAL & ASSEMBLY :

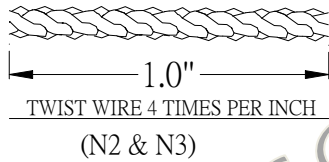

## 2. SCHEMATIC:

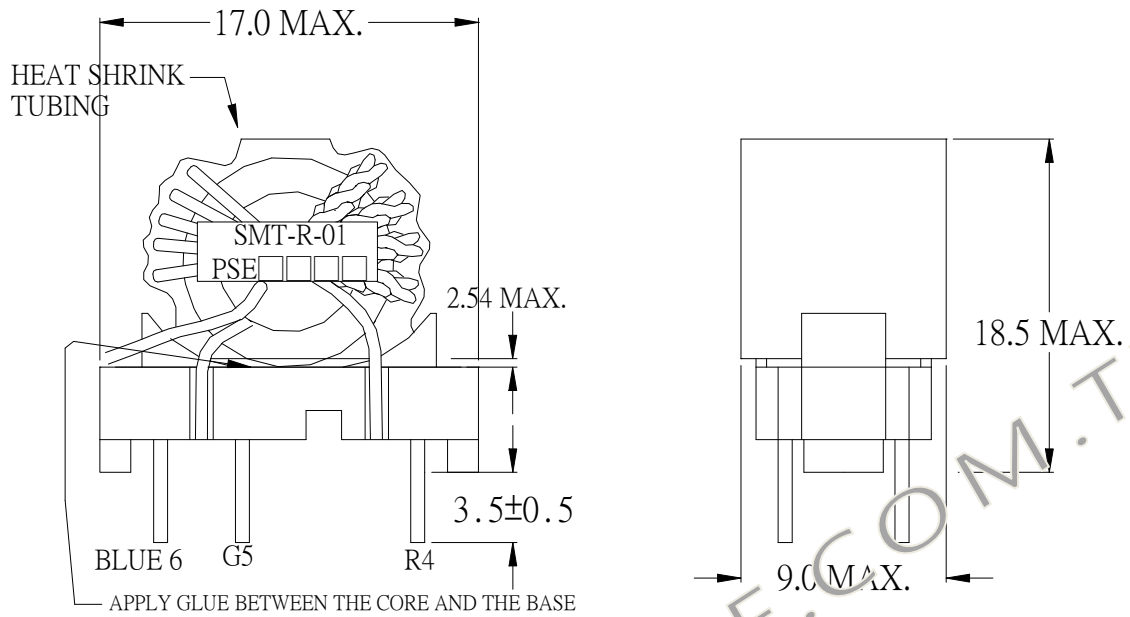
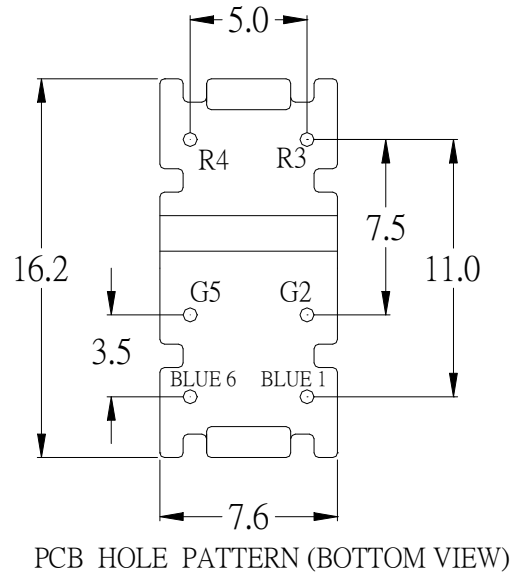
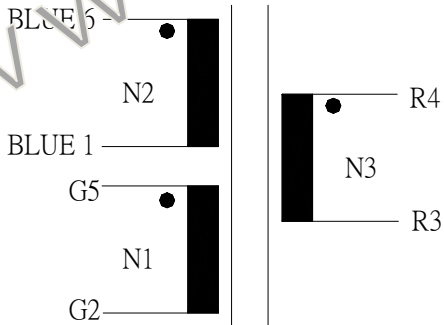

UNIT : mm

REPORT BY	CHECK BY	APPROVED BY	CUSTOMER :	DATE	
			PART NO : SMT-R-01	REV NO.	
			ISSUE NO : 75K-15001	PAGE	3 - 1

# 1. MECHANICAL & ASSEMBLY :

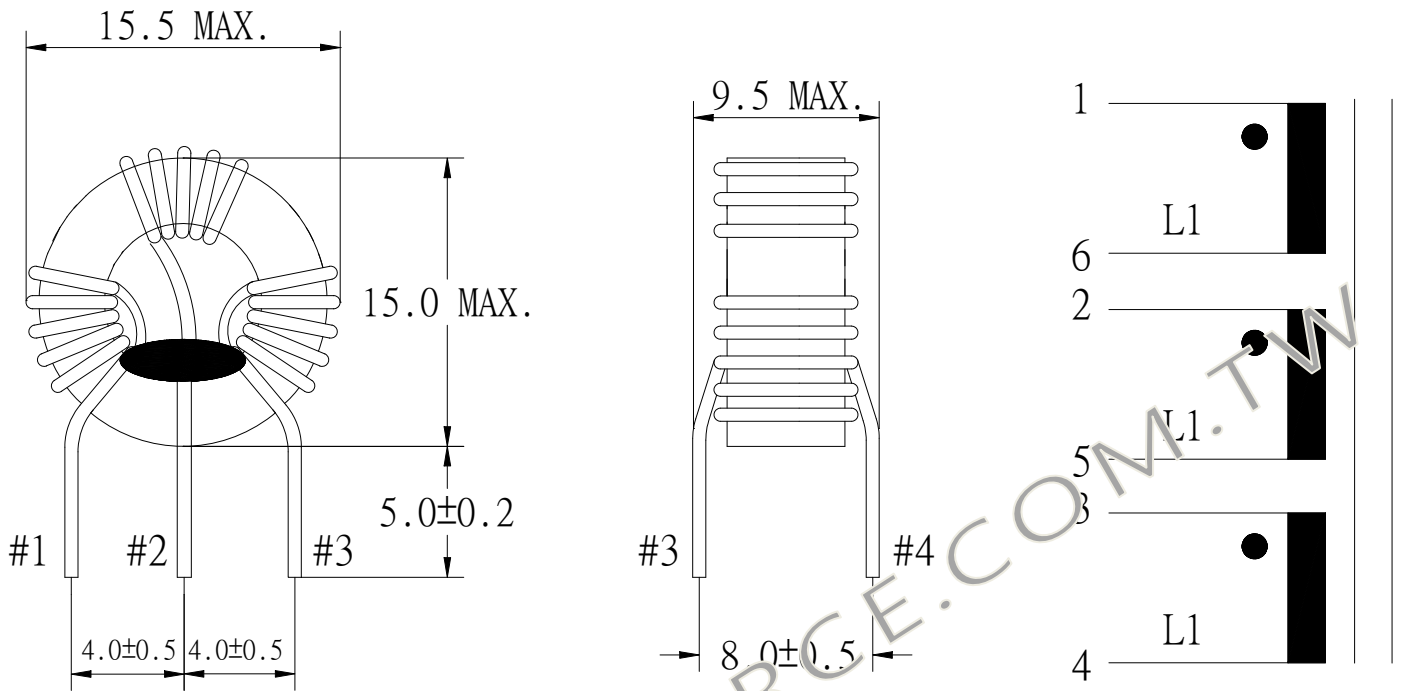

UNIT: m/m

# 2. WINDING CONFIGURATION:

STEP	WINDING	MARGIN TAPE	START-FINISH	COPPER WIRE	TURN	METHOD	TUBE
1	L1		1 - 6	0.65 $\phi$	6Ts REF.	CLOSE	
2	L2		2 - 5	0.65 $\phi$	6Ts REF.	CLOSE	
3	L3		3 - 4	0.65 $\phi$	6Ts REF.	CLOSE	

REPORT BY	CHECK BY	APPROVED BY	CUSTOMER :	DATE	
			PART NO : SMT-R-02	REV NO.	
			ISSUE NO : 82K-14013	PAGE	2 - 1

PRISOURCE ELECTRONICS CO., LTD.