

1. MECHANICAL & ASSEMBLY :

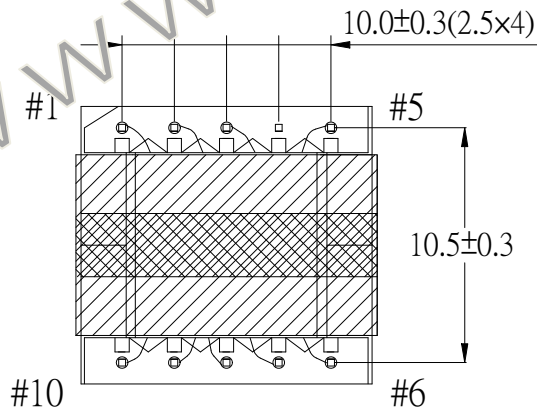
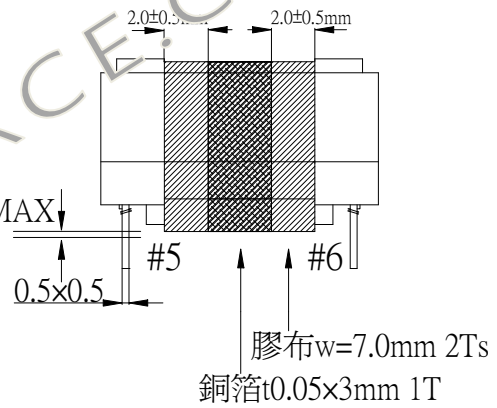
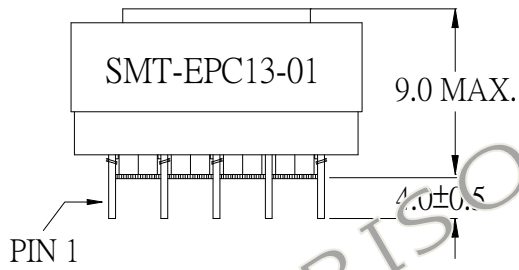
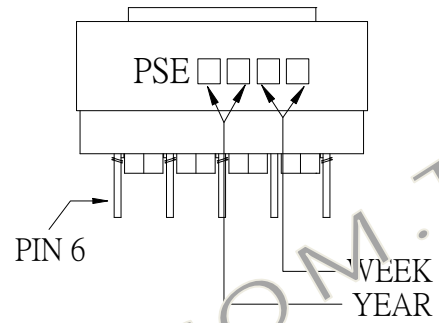
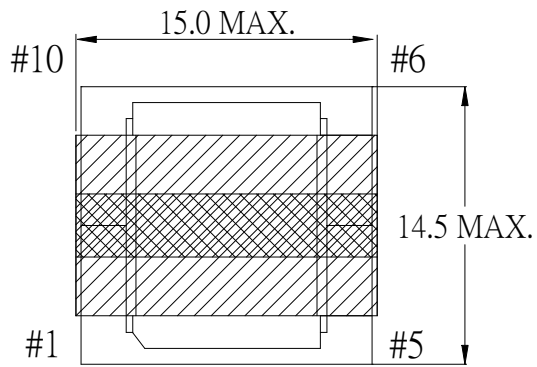

UNIT : m / m

REPORT BY	CHECK BY	APPROVED BY	CUSTOMER :	DATE	'
			PART NO : SMT-EPC13-01	REV NO.	
			ISSUE NO : 54P-2151	PAGE	4-1

1. MECHANICAL & ASSEMBLY :

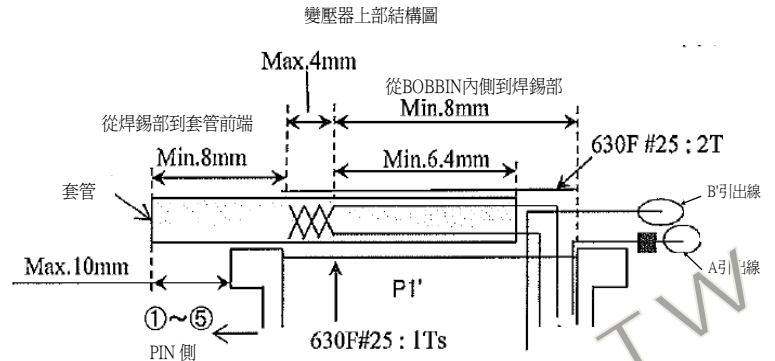
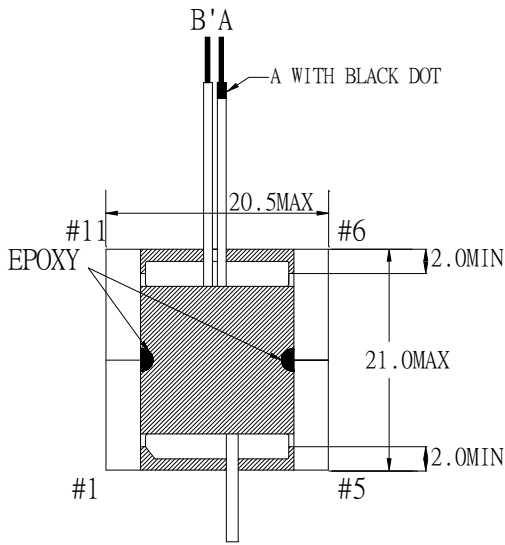
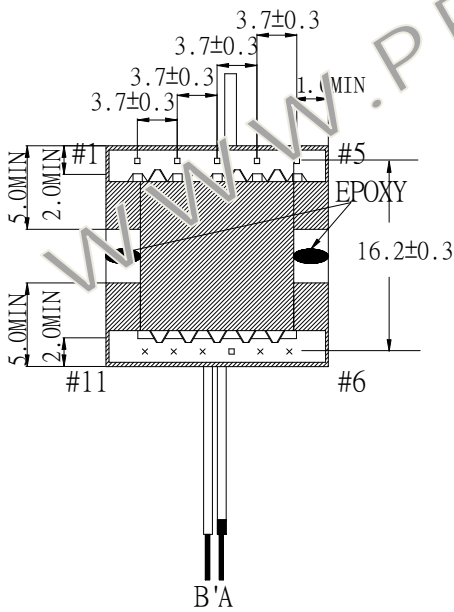
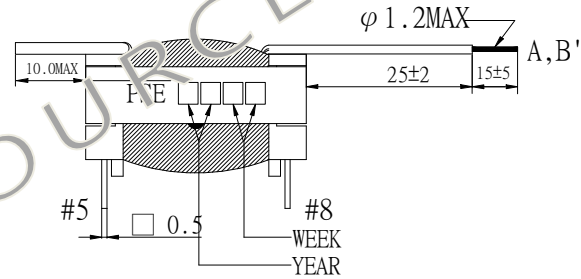
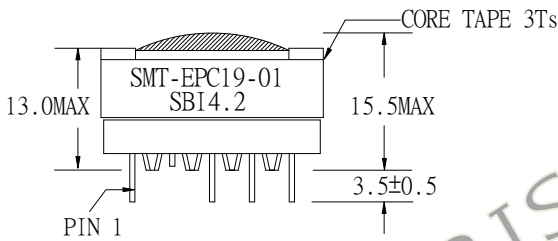

Figure 1



NOTE:

1. EPOXY FIXED BETWEEN CORE & CORE (TTL: 4 POINTS).
2. PIN 2 CUT SHORTER CAN NOT BE OVER STOPPER.
3. PIN 6,7,9,10,11 NO.

UNIT: mm

REPORT BY	CHECK BY	APPROVED BY	CUSTOMER :	DATE	
			PART NO : SMT-EPC19-01	REV NO.	
			ISSUE NO : 81P-12015-1	PAGE	4 - 1

1. MECHANICAL & ASSEMBLY :

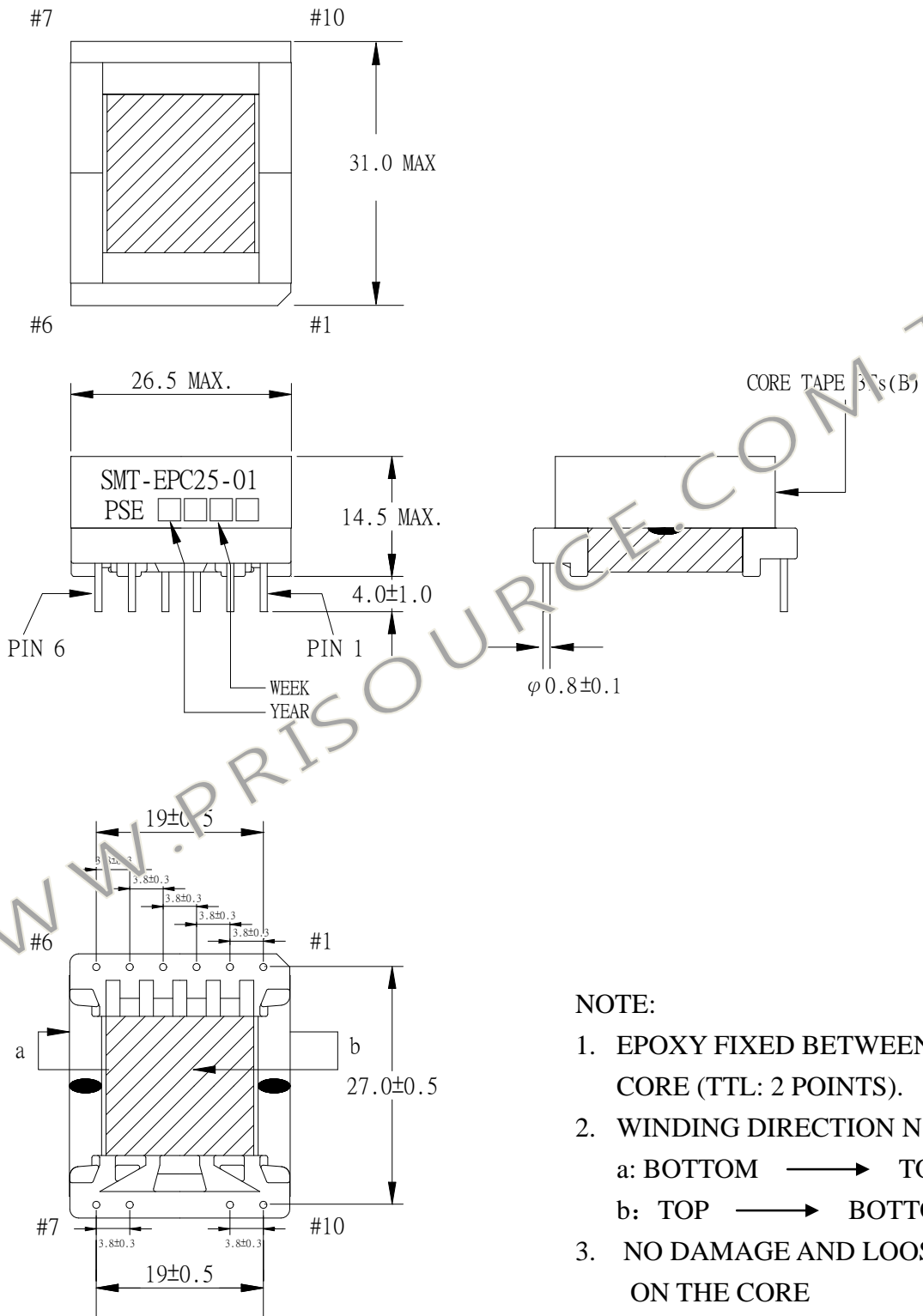

NOTE:

1. EPOXY FIXED BETWEEN CORE & CORE (TTL: 2 POINTS).
2. WINDING DIRECTION N1,N2,N3,N4
 a: BOTTOM → TOP
 b: TOP → BOTTOM
3. NO DAMAGE AND LOOSENING ON THE CORE

UNIT : m/ m

REPORT BY	CHECK BY	APPROVED BY	CUSTOMER :	DATE	'
			PART NO : SMT-EPC25-01	REV NO.	
			ISSUE NO : 54P-14103	PAGE	4 - 1