

1. MECHANICAL & ASSEMBLY :

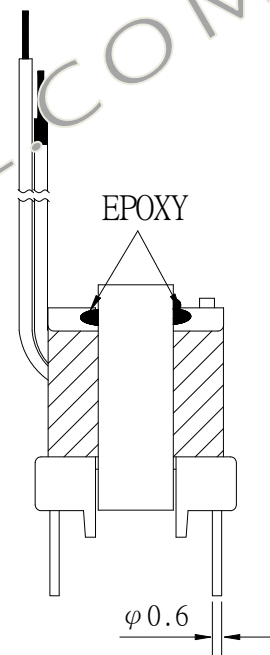
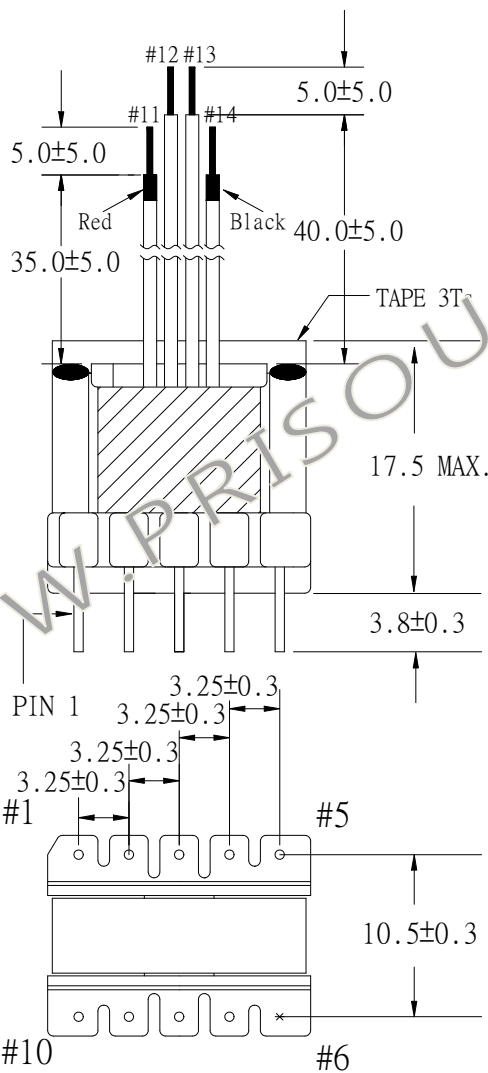
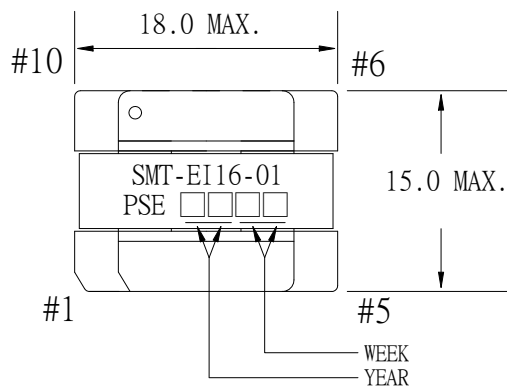

NOTE:

1. PIN 6 NO
2. EPOXY FIXED BETWEEN CORE & CORE (TTL:4 POINTS)

UNIT : m/ m

REPORT BY	CHECK BY	APPROVED BY	CUSTOMER :	DATE	
			PART NO : SMT-EI16-01	REV	
			ISSUE NO : 54P-14095	PAGE	4 - 1

1. MECHANICAL & ASSEMBLY :

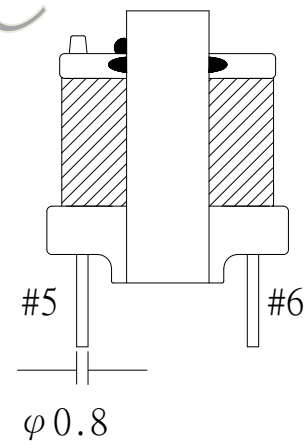
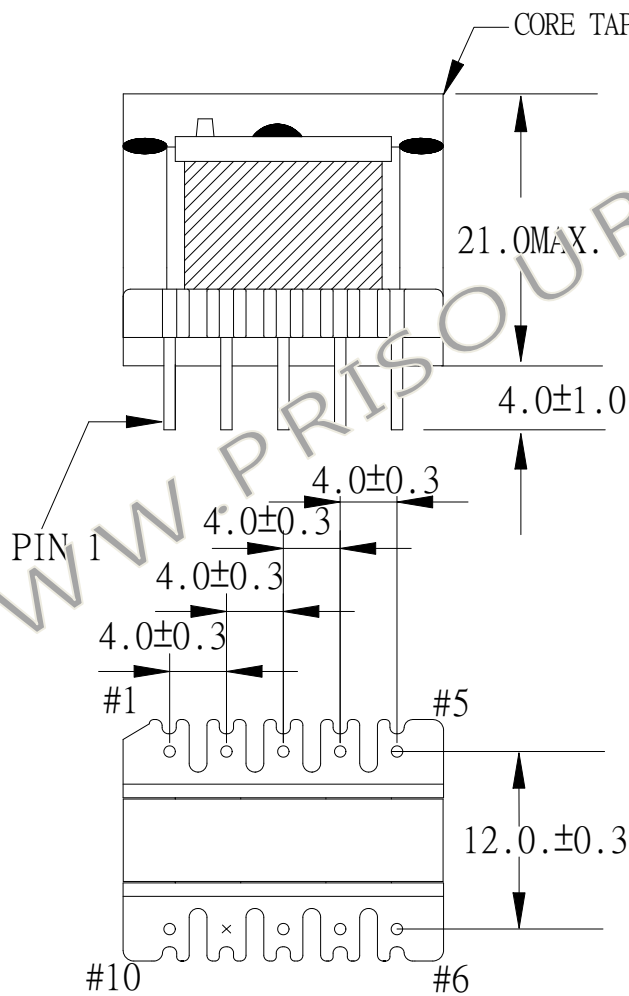
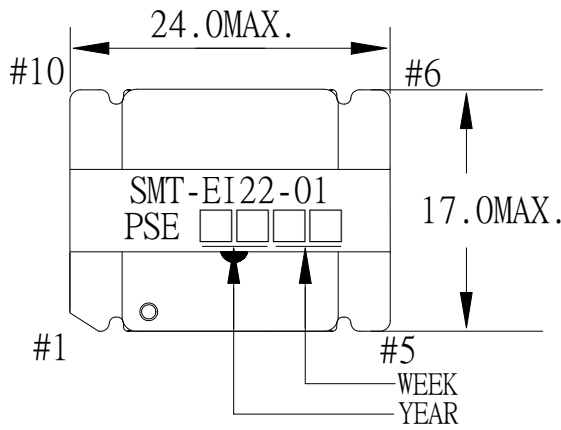

NOTE:

1. EPOXY FIXED BETWEEN E CORE & I CORE (TTL:4 POINTS).EPOXY FIXED BETWEEN I CORE & BOBBIN (AT PIN1-5SIDE).
2. ADHESIVE KE-45W ON CORE CENTER LEG(ONE POINT)
3. PIN 9 NO
4. NOT dipped in varnish

UNIT: m/m

REPORT BY	CHECK BY	APPROVED BY	CUSTOMER :	DATE	
			PART NO : SMT-EI22-01	REV	
			ISSUE NO : 82P-13018	PAGE	4 - 1

1. MECHANICAL & ASSEMBLY :

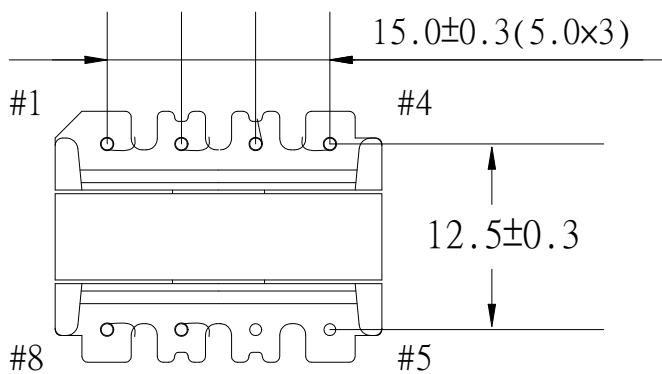
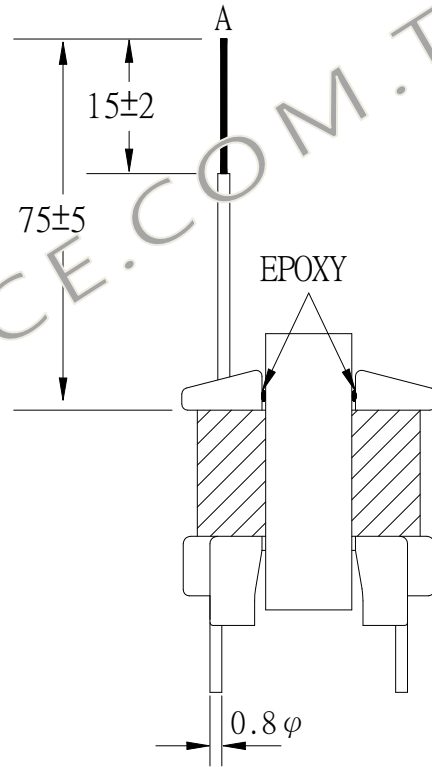
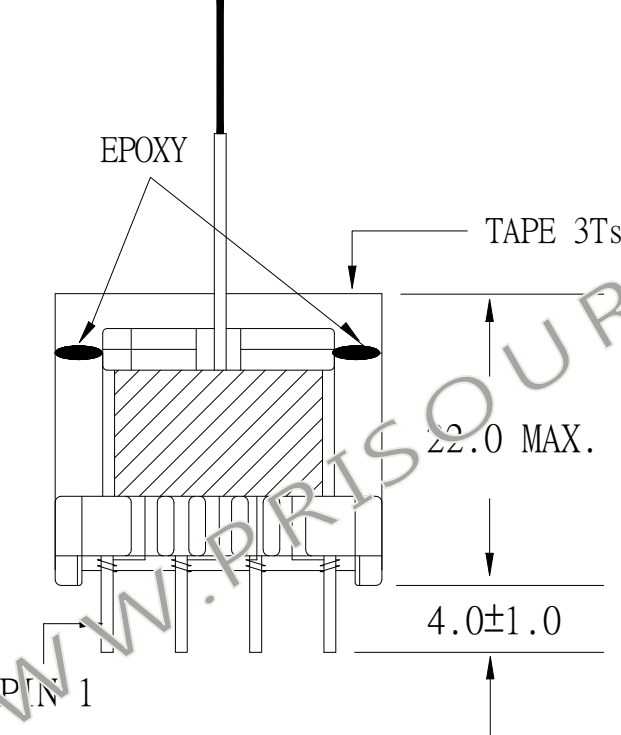
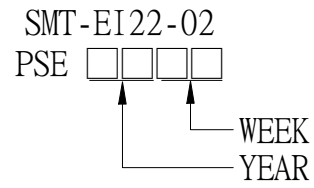
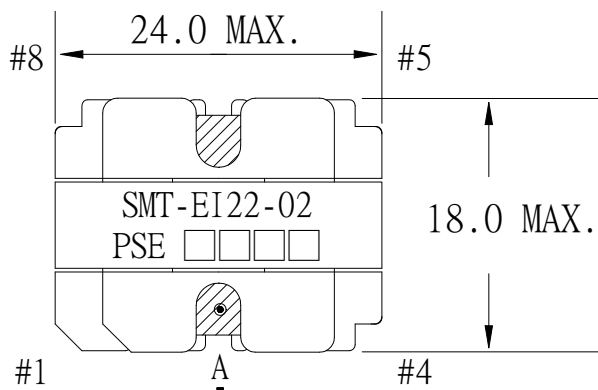

NOTE:

1. EPOXY FIXED BETWEEN E CORE & I CORE (TTL:4 POINTS).

UNIT : m/ m

REPORT BY	CHECK BY	APPROVED BY	CUSTOMER :	DATE	
			PART NO : SMT-EI22-02	REV NO.	
			ISSUE NO : 54P-4057	PAGE	4 - 1

1. MECHANICAL & ASSEMBLY :

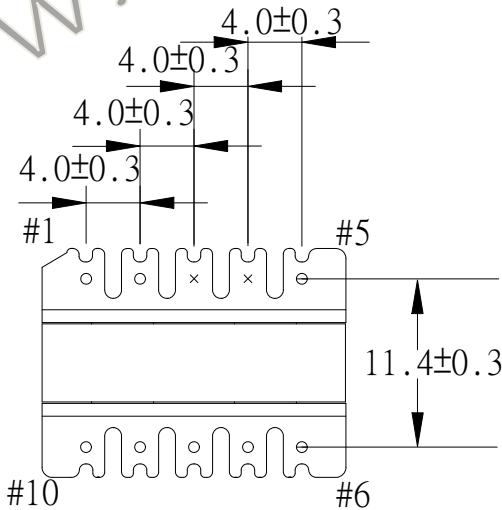
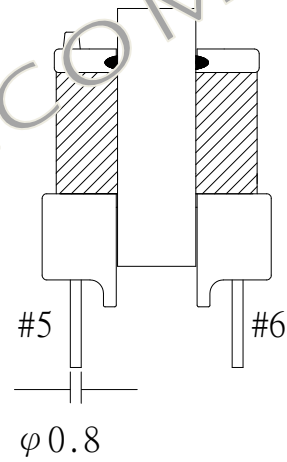
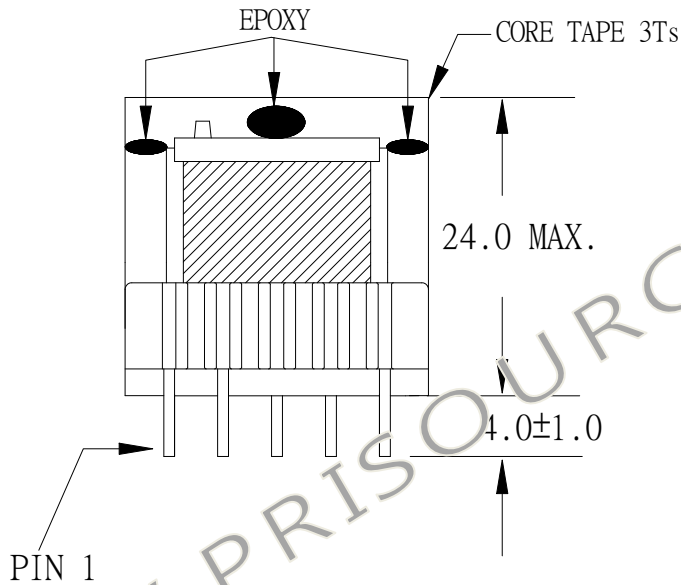
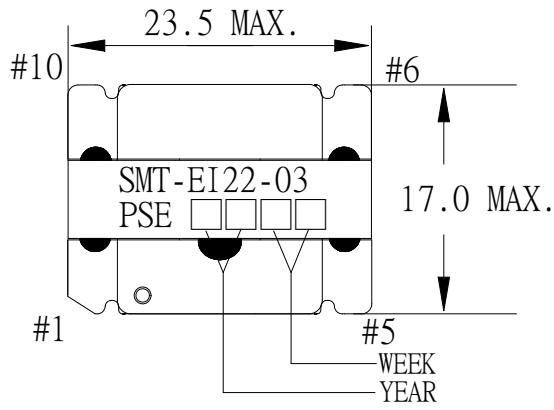

NOTE:

1. EPOXY FIXED BETWEEN CORE & CORE (TTL:4 POINTS) EPOXY FIXED TOP OF BOBBIN & CORE.(ONE POINT AT PIN1-5 SIDE).
2. ADHESIVE KE-45W ON CORE CENTER LEG(ONE POINT)
3. PIN 3,4 NO

UNIT: m/m

REPORT BY	CHECK BY	APPROVED BY	CUSTOMER :	DATE	
			PART NO : SMT-EI22-03	REV NO.	
			ISSUE NO : 82P-14012	PAGE	4 - 1

1. MECHANICAL & ASSEMBLY :

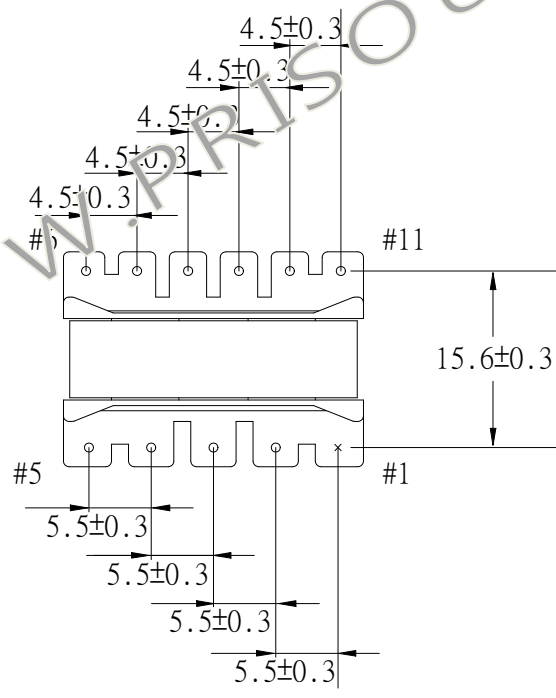
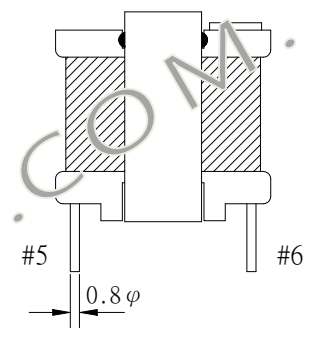
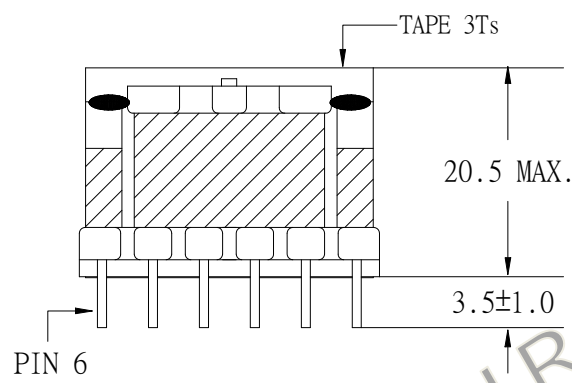
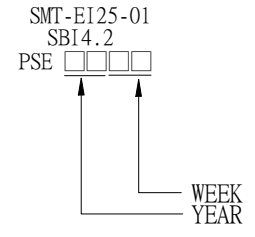
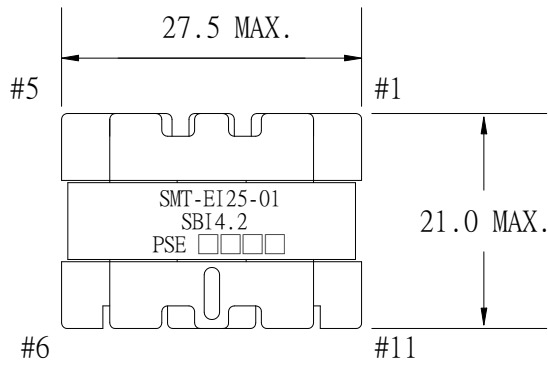

NOTE:

1. EPOXY FIXED BETWEEN CORE & CORE (TTL:4 POINTS)
2. PIN 1 NO

UNIT : mm

REPORT BY	CHECK BY	APPROVED BY	CUSTOMER :	DATE	
			PART NO : SMT-EI25-01	REV NO.	
			ISSUE NO : 54P-15003	PAGE	4 - 1

1. MECHANICAL & ASSEMBLY :

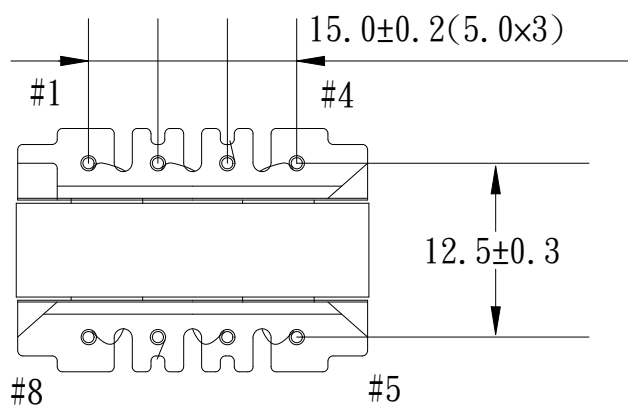
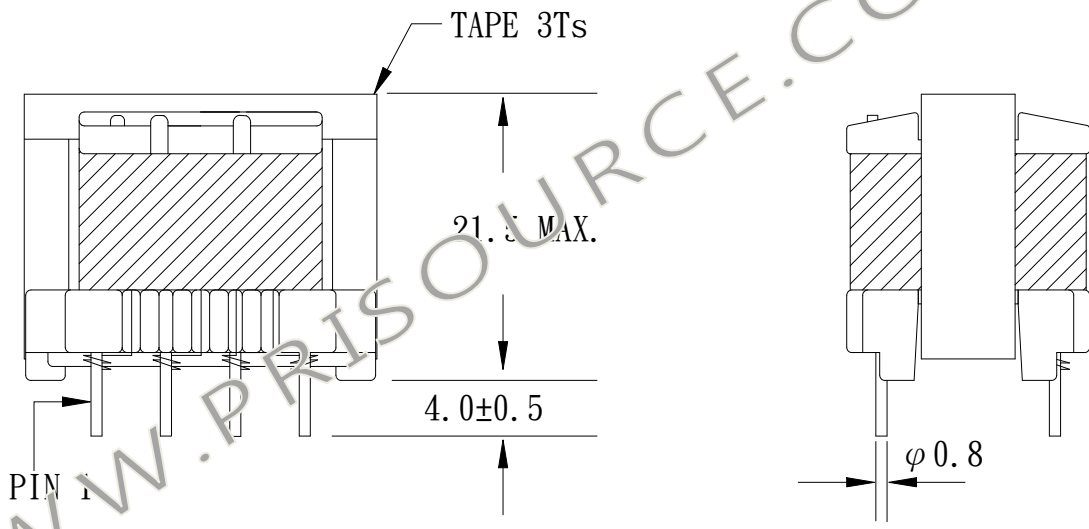
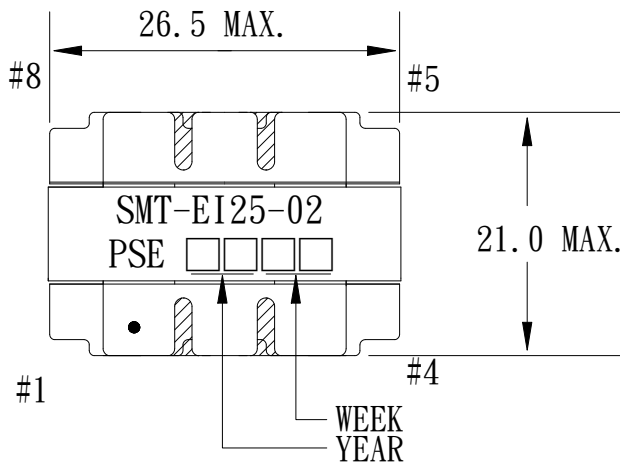

UNIT : m/ m

REPORT BY	CHECK BY	APPROVED BY	CUSTOMER :	DATE	
			PART NO : SMT-EI25-02	REV NO.	
			ISSUE NO : 54P-4056	PAGE	4 - 1

1. MECHANICAL & ASSEMBLY :

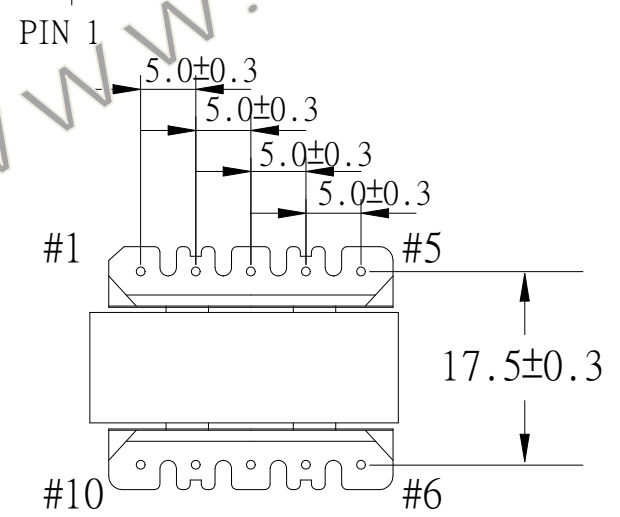
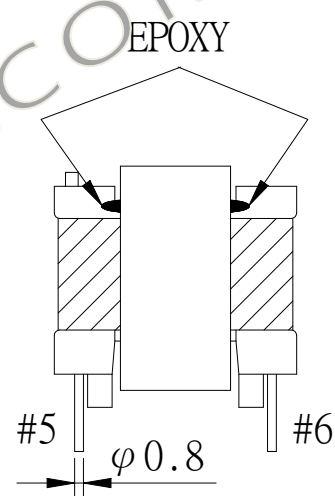
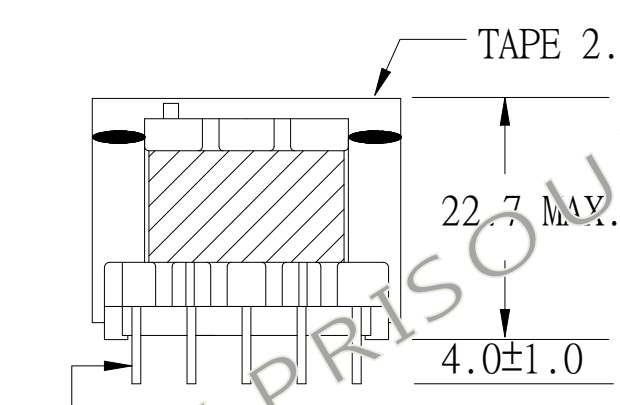
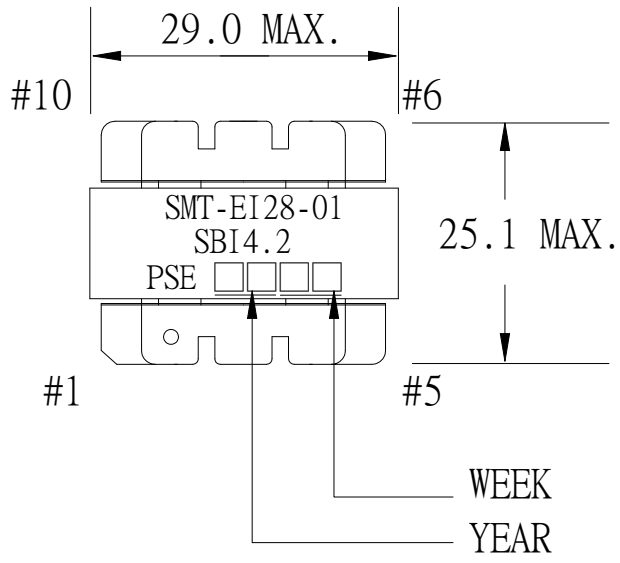

- NOTE:
1. EPOXY FIXED BETWEEN CORE & CORE (TTL: 4 POINTS).
 2. MEET CLASS B INSULATION SYSTEM " SBI4.2 " E181448

UNIT : m/ m

REPORT BY	CHECK BY	APPROVED BY	CUSTOMER:	DATE	
			PART NO : SMT-EI28-01	REV NO.	
			ISSUE NO : 76P-14007	PAGE	4 - 1

1. MECHANICAL & ASSEMBLY :

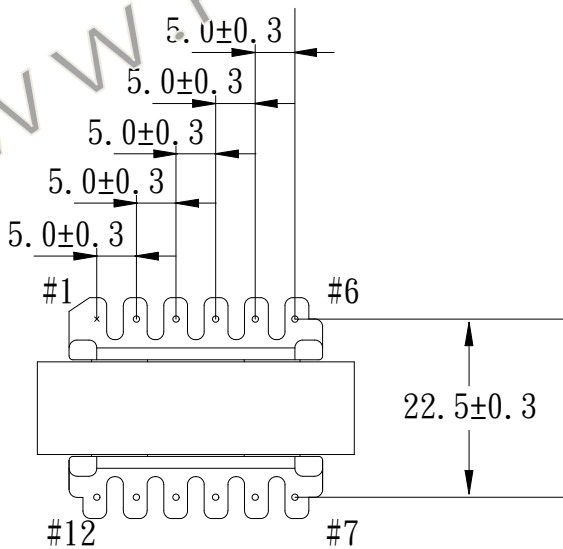
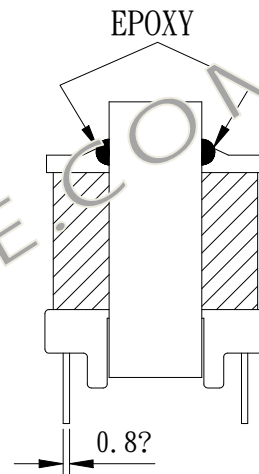
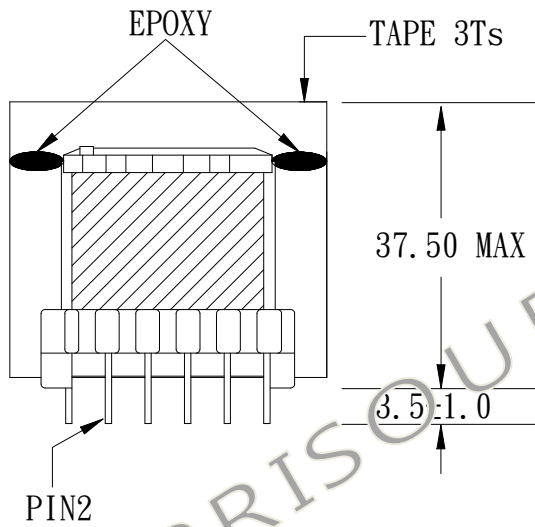
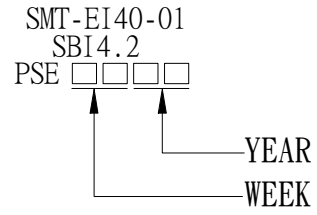
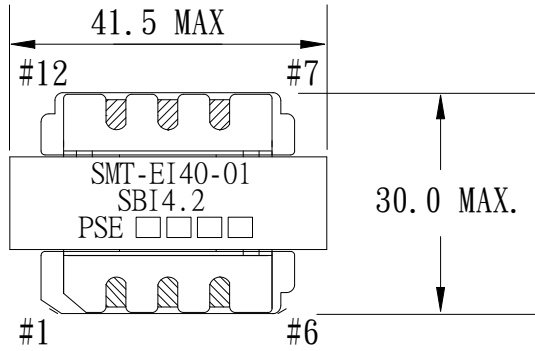

NOTE:

- EPOXY FIXED BETWEEN CORE & CORE (TTL:4 POINTS)

UNIT : m/ m

REPORT BY	CHECK BY	APPROVED BY	CUSTOMER :	DATE	
			PART NO : SMT-EI40-01	REV	
			ISSUE NO : 54P-15002	PAGE	4 - 1

1. MECHANICAL & ASSEMBLY :

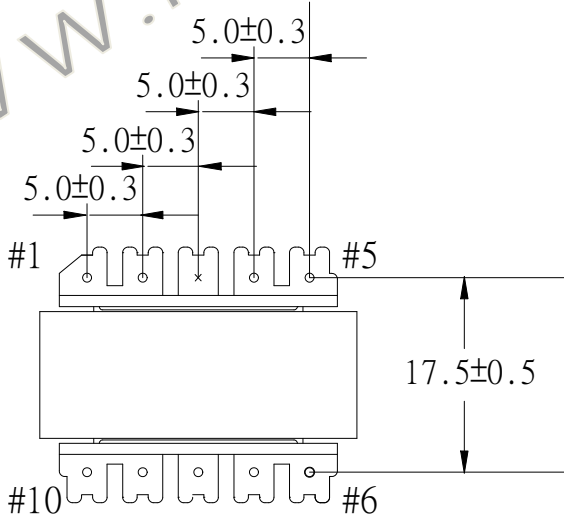
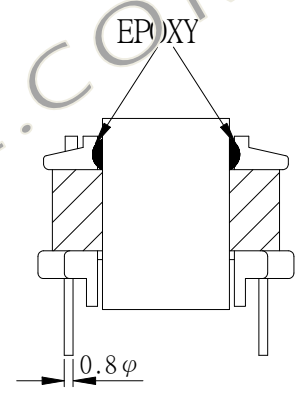
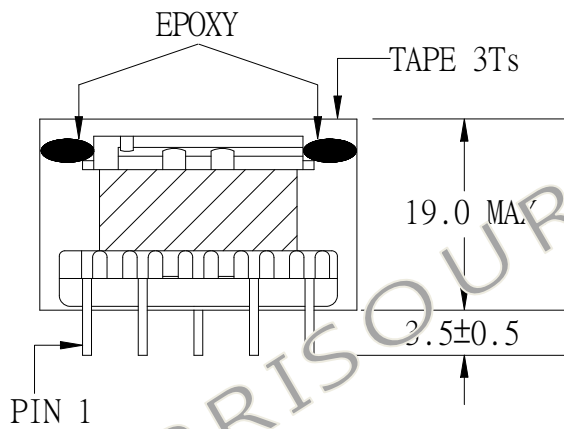
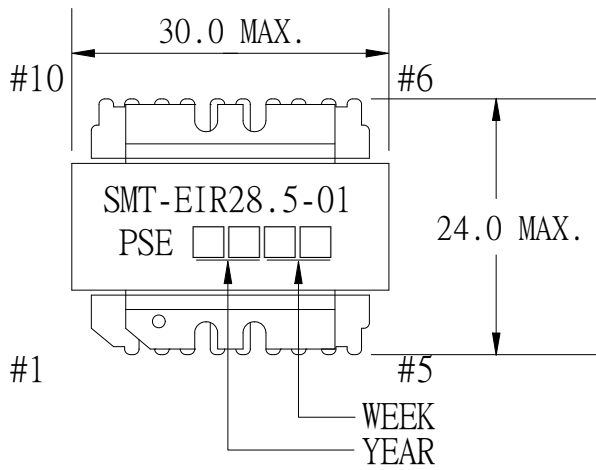

NOTE:

1. EPOXY FIXED BETWEEN CORE & CORE (TTL:4 POINTS)
2. PIN 3 NO.

UNIT : m/ m

REPORT BY	CHECK BY	APPROVED BY	CUSTOMER :	DATE	
			PART NO : SMT-EIR28.5-01	REV	
			ISSUE NO : 54P-14133	PAGE	4 - 1