

1. MECHANICAL & ASSEMBLY :

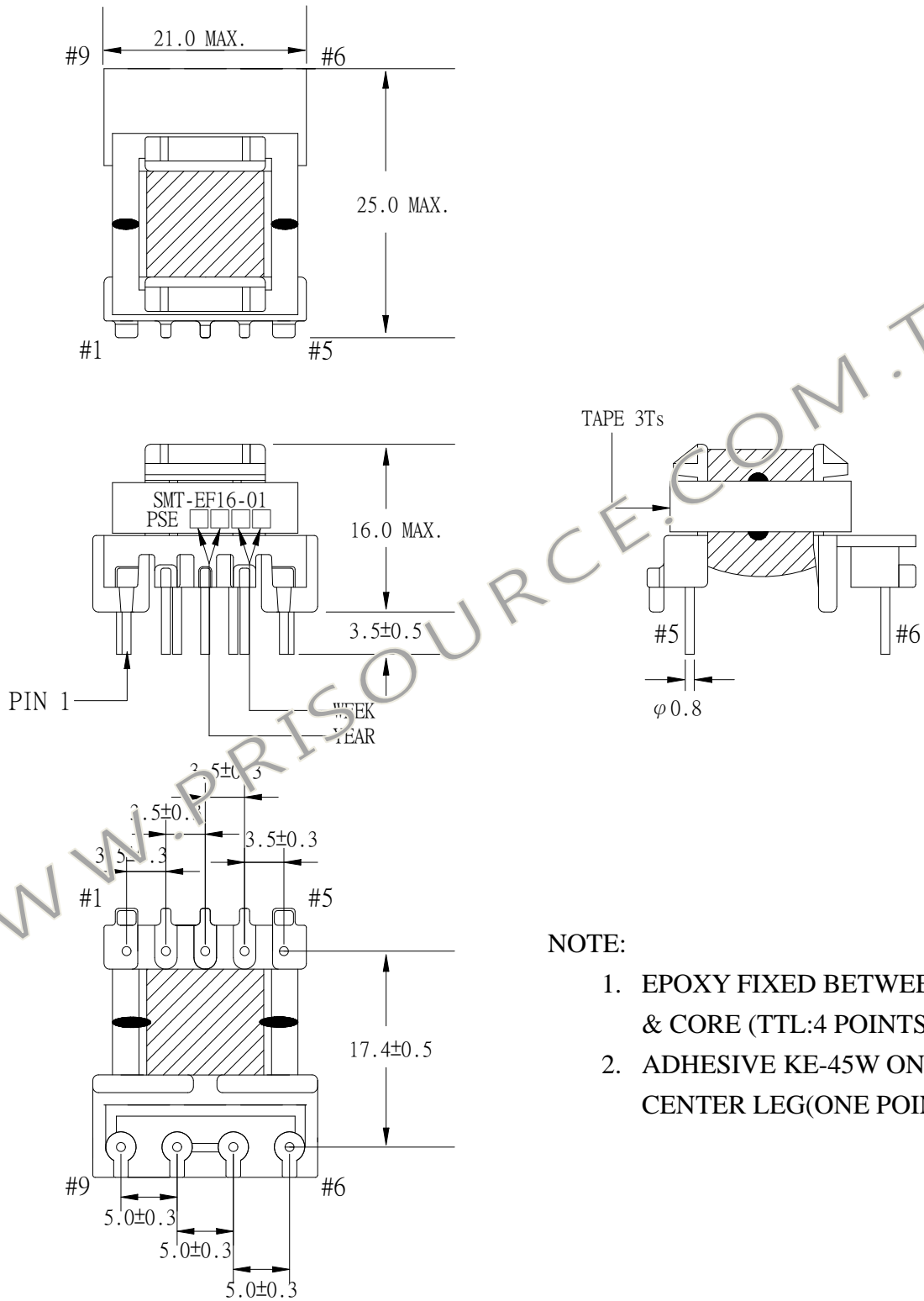

NOTE:

1. EPOXY FIXED BETWEEN CORE & CORE (TTL:4 POINTS)
2. ADHESIVE KE-45W ON CORE CENTER LEG(ONE POINT)

UNIT : m/ m

| | | | | | |
|-----------|----------|-------------|-----------------------|---------|-----|
| REPORT BY | CHECK BY | APPROVED BY | CUSTOMER : | DATE | |
| | | | PART NO : SMT-EF16-01 | REV NO. | |
| | | | ISSUE NO : 82P-10009 | PAGE | 4-1 |

1. MECHANICAL & ASSEMBLY :

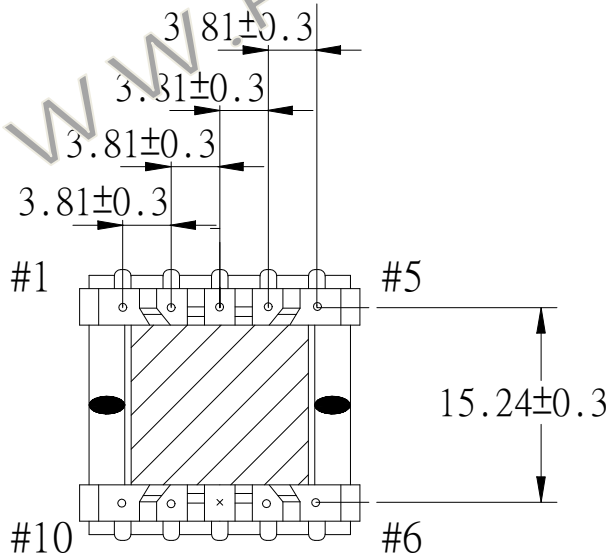
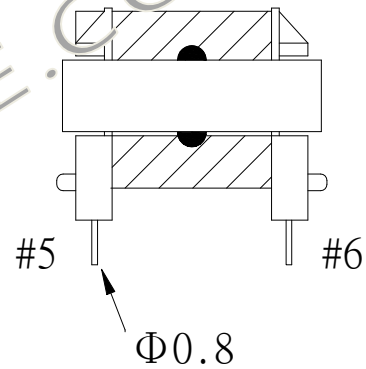
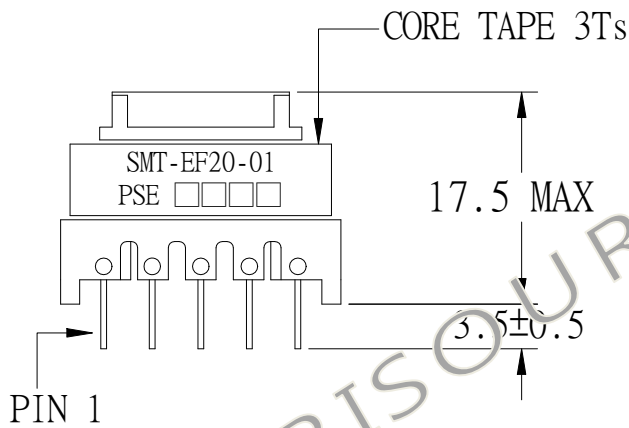
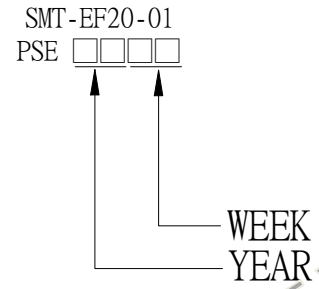
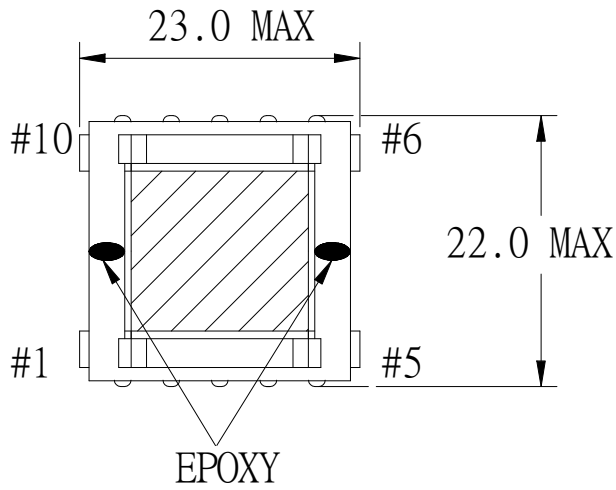

NOTE:

1. PIN 8 NO.
2. EPOXY FIXED BETWEEN CORE & CORE (TTL: 4 POINTS) EPOXY FIXED BETWEEN BOBBIN & CORE. (PIN 1-5 SIDE ONE POINT).

UNIT : m/m

| | | | | | |
|-----------|----------|-------------|----------------------|------|-------|
| REPORT BY | CHECK BY | APPROVED BY | CUSTOMER : | DATE | |
| | | | PART NO : | REV | |
| | | | ISSUE NO : 67P-14001 | PAGE | 4 - 1 |