

1. MECHANICAL & ASSEMBLY :

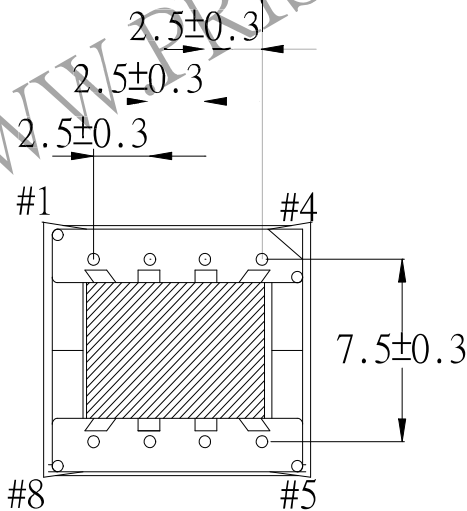
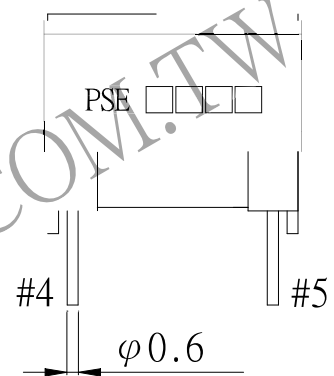
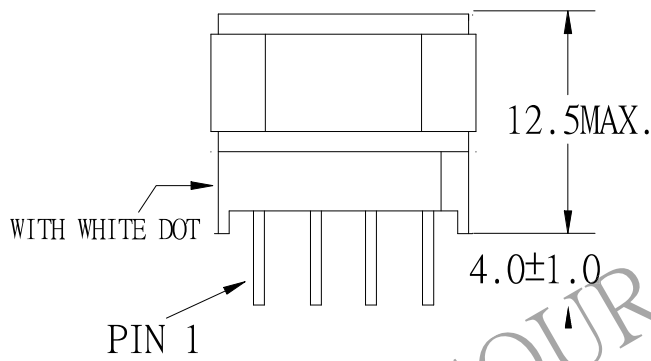
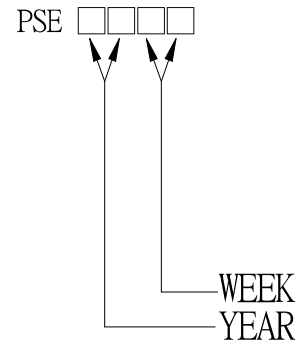
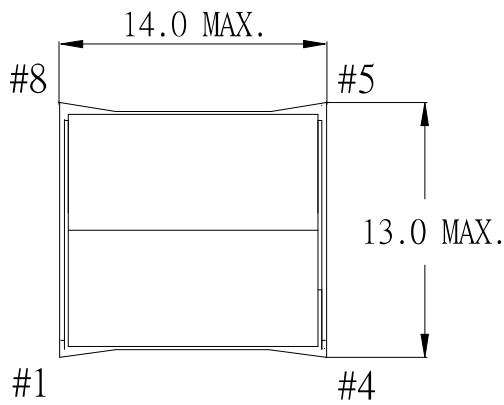

NOTE:
PIN 1 WITH WHITE DOT

UNIT:m/m

| | | | | | | | | |
|--------|----|-------|----|----------|----|---------------------|---------|-------|
| REPORT | BY | CHECK | BY | APPROVED | BY | CUSTOMER : | DATE | |
| | | | | | | PART NO : 83P-16001 | REV NO. | |
| | | | | | | ISSUE NO : | PAGE | 4 - 1 |

2. WINDING CONFIGURATION :

| STEP | WINDING | MARGIN TAPE | START-FINISH | COPPER WIRE | URNS | LAYER TAPE | TUBE | METHOD |
|------|---------|-------------|--------------|-------------|------|------------|------|-------------|
| 1 | W1 | | 6 - 8 | φ0.25 | 36 | 2Ts | | CLOSE SPACE |
| 2 | W2 | | 4 - 2 | φ0.25 | 36 | 2Ts | | CLOSE SPACE |
| | | | | | | | | |
| | | | | | | | | |
| | | | | | | | | |
| | | | | | | | | |
| | | | | | | | | |

NOTE:

3. ELECTRICAL CHARACTERISTICS :

| PIN NO. | INDUCTANCE 1.0KHz, 1.0Vrms | LEAKAGE INDUCTANCE KHz, Vrms | VOLTAGE RATIO(V) F= 20KHz | DCR MAX. AT 25°C |
|---------|-------------------------------|---------------------------------|------------------------------|---------------------|
| 6 - 8 | 100.0uH ±20% | | INPUT 1Vrms | 260.0 mΩ |
| 4 - 2 | | | 1.003 Vrms±3.0% | 320.0 mΩ |
| | | | | |
| | | | | |
| | | | | |
| | | | | |

HI-POT TEST :(AT 1mA , 2 SEC.)

PRI. TO SEC. 600 VAC
 PRI. TO CORE. 600 VAC
 SEC. TO CORE. 600 VAC

INSULATION RESISTANCE:(AT DC 500V)

PRI. TO SEC. 100 MΩ MIN.
 PRI. TO CORE. 100 MΩ MIN.
 SEC. TO CORE. 100 MΩ MIN.

| REPORT BY | CHECK BY | APPROVED BY | CUSTOMER : | DATE |
|-----------|----------|-------------|---------------------|------------|
| | | | PART NO : 83P-16001 | REV NO. |
| | | | ISSUE NO : | PAGE 4 - 2 |

4. WINDING SEQUENCE :

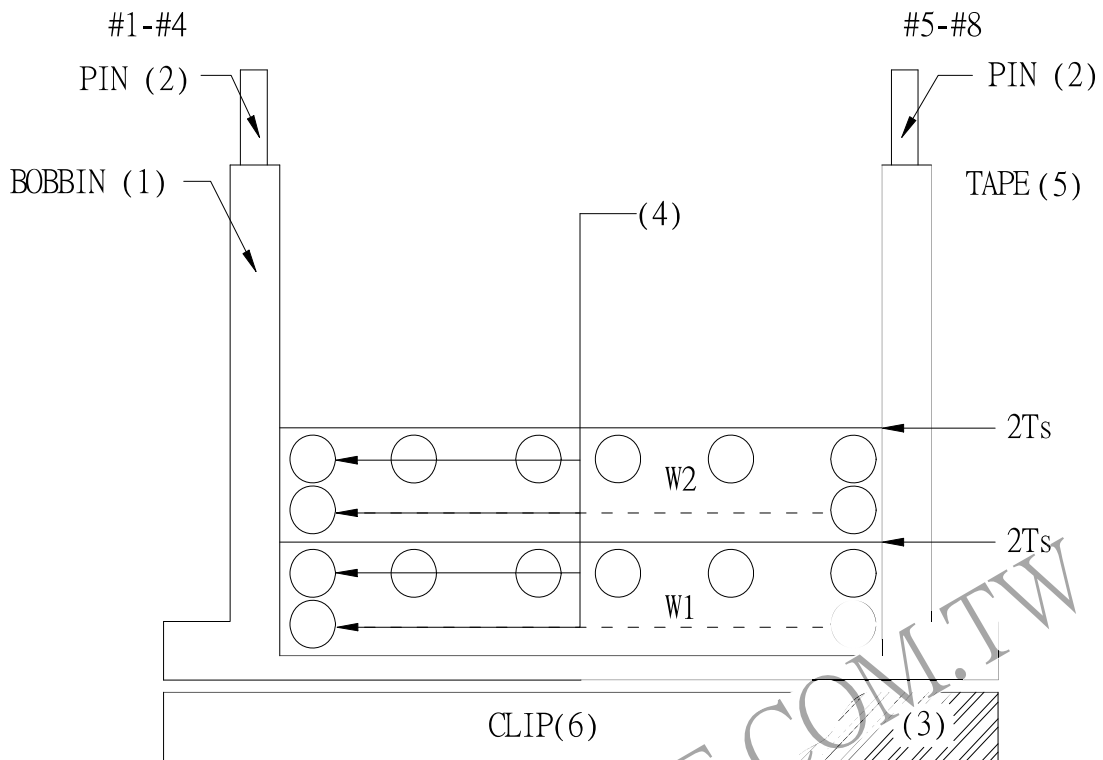

W2 WINDING FROM PIN 1-4 SIDE

W1 WINDING FROM PIN 5-8 SIDE

5. SCHEMATIC :

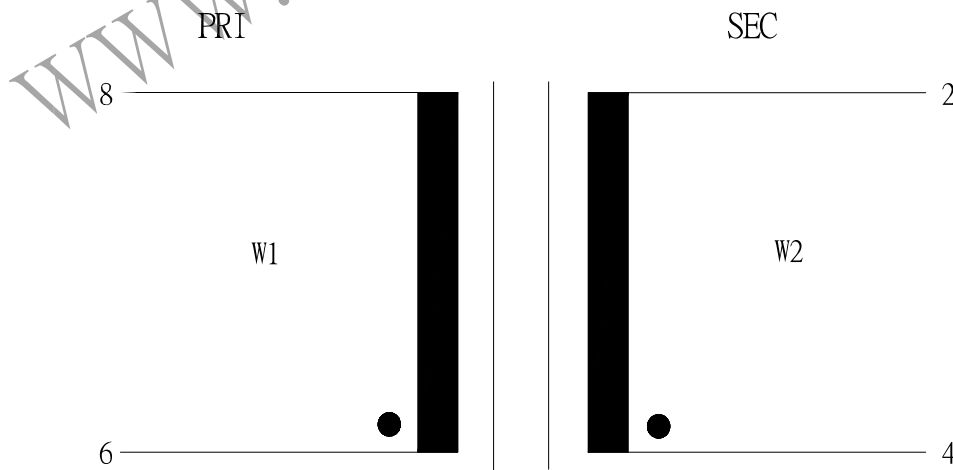

| | | | | | |
|-----------|----------|-------------|---------------------|---------|-------|
| REPORT BY | CHECK BY | APPROVED BY | CUSTOMER : | DATE | |
| | | | PART NO : 83P-16001 | REV NO. | |
| | | | ISSUE NO : | PAGE | 4 - 3 |