

1. MECHANICAL & ASSEMBLY :

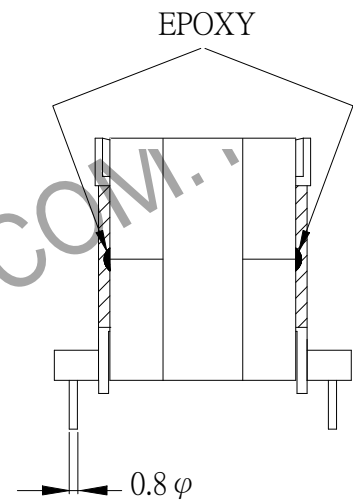
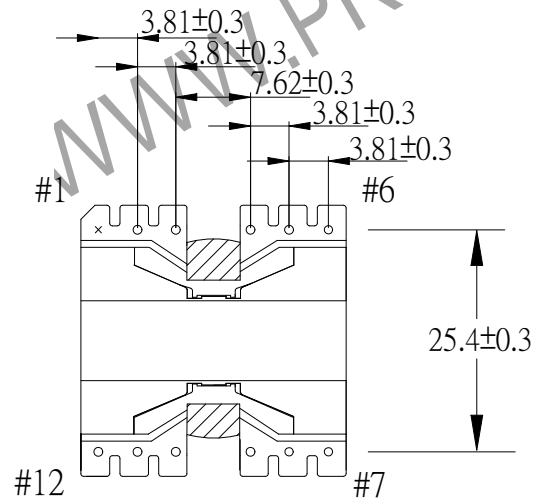
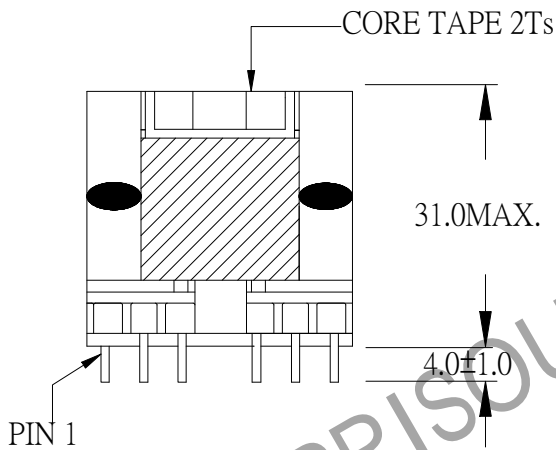
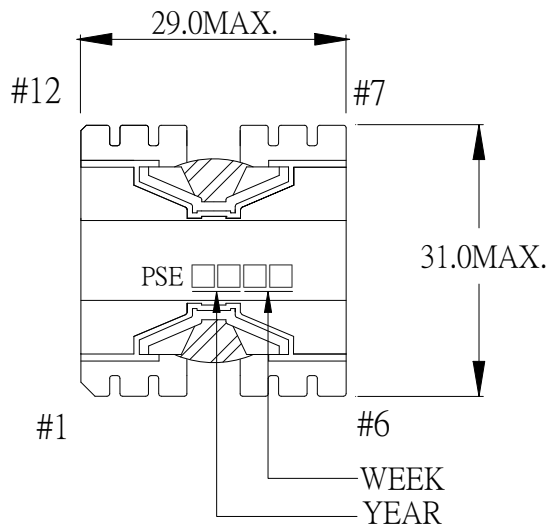

NOTE:

1. EPOXY FIXED BETWEEN CORE & CORE (TTL:4 POINTS). EPOXY FIXED TOP OF BOBBIN & CORE.(ONE POINT).
2. PIN 1 NO

UNIT : m/ m

REPORT BY	CHECK BY	APPROVED BY	CUSTOMER :	DATE	
			PART NO : 83P-14008	REV NO.	
			ISSUE NO :	PAGE	4 - 1

## 2. WINDING CONFIGURATION :

STEP	WINDING	MARGIN TAPE	START-FINISH	COPPER WIRE	TURNS	LAYER TAPE	METHOD
1	W1		2 - 4	0.10 $\phi$ /100C	8	2Ts	CLOSE
2	W2		10 - 8	0.65 $\phi$	18	2Ts	CLOSE
3	W3		3 - 5	0.10 $\phi$ /100C	8	2Ts	CLOSE

NOTE:

## 3. ELECTRICAL CHARACTERISTICS :

PIN NO.	INDUCTANCE 1.0 KHz, 0.3Vrms	LEAKAGE INDUCTANCE KHz, Vrms	VOLTAGE RATIO(V) f= 20KHz	DCR MAX AT 25°C
2,3 - 4,5	30.0uH $\pm$ 7.0%		0.4424Vrms $\pm$ 4.0%	7.0 m $\Omega$
10 - 8			INPUT 1Vrms	67.0 m $\Omega$

HI-POT TEST : (AT 1 mA, 2 SEC)

PRI TO SEC. 600 VAC

PRI, SEC TO CORE. 600 VAC

INSULATION RESISTANCE: (AT DC 500V)

PRI TO SEC. 100 M $\Omega$  MIN.

PRI, SEC TO CORE. 100 M $\Omega$  MIN.

REPORT BY	CHECK BY	APPROVED BY	CUSTOMER :	DATE
			PART NO : 83P-14008	REV NO.
			ISSUE NO :	PAGE 4 - 2

#### 4. WINDING SEQUENCE:

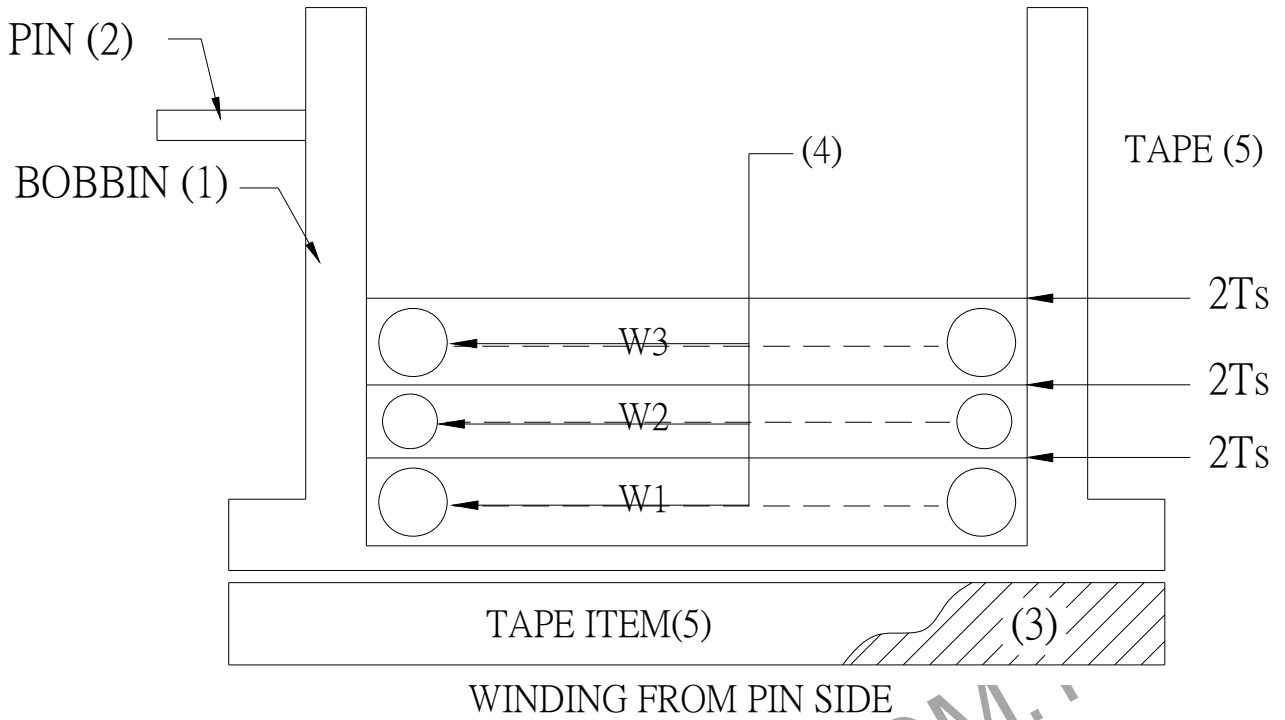

#### 5. SCHEMATIC:

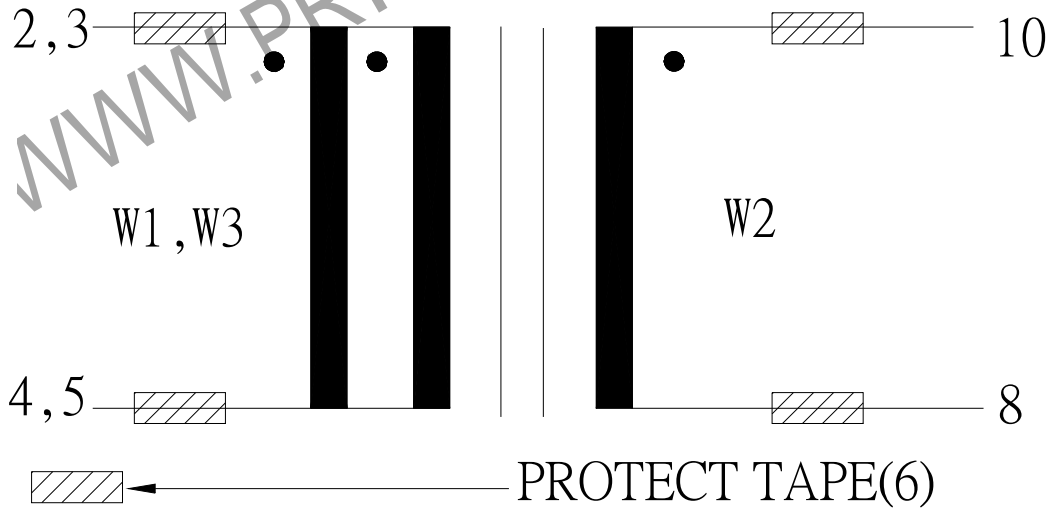

REPORT	BY	CHECK	APPROVED BY	CUSTOMER :	DATE	
				PART NO : 83P-14008	REV NO.	
				ISSUE NO :	PAGE	4 - 3

## 6. MATERIAL LIST :

NO.	DESCRIPTION	ITEM	MATERIAL	LIST OF SAMPLE	UL NO.	MANUFACTURER
1	BOBBIN	(1)	PHENOLIC (PM9820) Thickness:0.30 mm Min.	✓	E41429	SUMITOMO
2	PIN	(2)	TINNED C.P WIRE φ 0.8	✓		WELL FORE
3	CORE	(3)	FERRITE CORE			
4	COPPER WIRE	(4)	PQ26/25 TP4A POLYURETHANE (1UEW) TYPYU-130 MW75-C	✓ ✓	E197768	TDG HENG YA
5	MYLAR TAPE	(5)	POLYESTER FILM #1318-1 Y	✓	E17385	3M
6	PROTECT TAPE	(6)	COMPOSITE FILM #44-A	✓	E17385	3M
7	EPOXY		6020H	✓	E229633	WELLS
8	VARNISH		TVB2180T	✓	E83702	KYOCERA

REPORT BY	CHECK BY	APPROVED BY	CUSTOMER :	DATE	
			PART NO : 83P-14008	REV NO.	
			ISSUE NO :	PAGE	4 - 4