

1. MECHANICAL & ASSEMBLY :

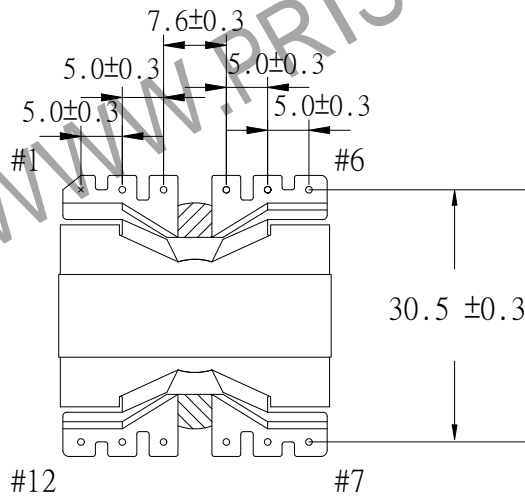
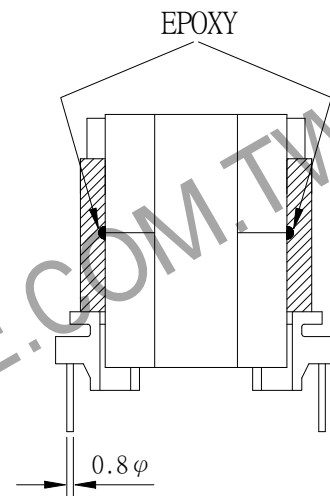
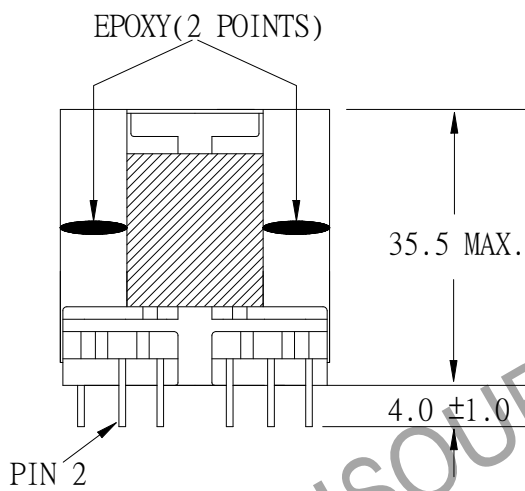
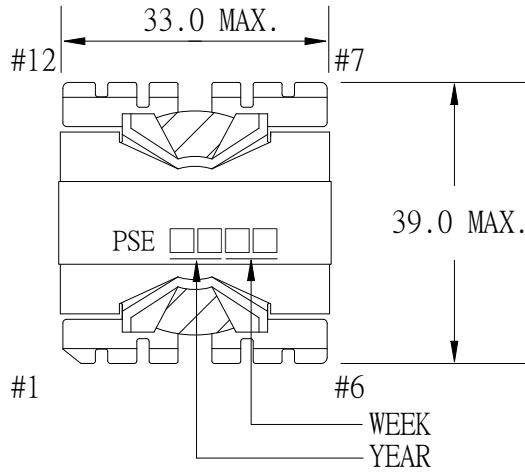

NOTE:

1. EPOXY FIXED BETWEEN CORE & CORE (TTL:4 POINTS)
2. EPOXY FIXED TOP OF BOBBIN & CORE.(ONE POINT)
3. PIN 1 NO
4. **SOLDER POINT CAN NOT BE OVER STAND OFF**

UNIT:mm

REPORT BY	CHECK BY	APPROVED BY	CUSTOMER :	DATE
			PART NO : 83P-14003	REV NO.
			ISSUE NO :	PAGE
				4 - 1

2. WINDING CONFIGURATION :

STEP	WINDING	MARGIN TAPE	START-FINISH	COPPER WIRE	TURNS	LAYER TAPE	TUBE	METHOD
1	W1		2 - 4	0.10 ϕ /100C	10	2Ts		CLOSE
2	W2		10 - 8	0.10 ϕ /100C \times 2	5	2Ts		CLOSE
3	W3		11 - 9	0.10 ϕ /100C \times 2	5	2Ts		CLOSE
4	W4		3 - 5	0.10 ϕ /100C	10	2Ts		CLOSE

NOTE:

3. ELECTRICAL CHARACTERISTICS :

PIN NO.	INDUCTANCE 1.0 KHz, 0.3Vrms	LEAKAGE INDUCTANCE KHz, Vrms	VOLTAGE RATIO(V) F= 20KHz INPUT 1Vrms	DCR MAX. AT 25°C
2,3 - 4,5	180.0uH \pm 15%			10.0m Ω
10,11 - 8,9			0.5000Vrms \pm 3.0%	3.0m Ω

HI-POT TEST:(AT 1 mA, 2SEC.)

PRI TO SEC 600 VAC

PRI, SEC TO CORE 600 VAC

INSULATION RESISTANCE:(AT DC 500V)

PRI TO SEC 100 M Ω MIN.

PRI, SEC TO CORE 100 M Ω MIN.

REPORT BY	CHECK BY	APPROVED BY	CUSTOMER :	DATE	
			PART NO : 83P-14003	REV NO.	
			ISSUE NO :	PAGE	4 - 2

4. WINDING SEQUENCE:

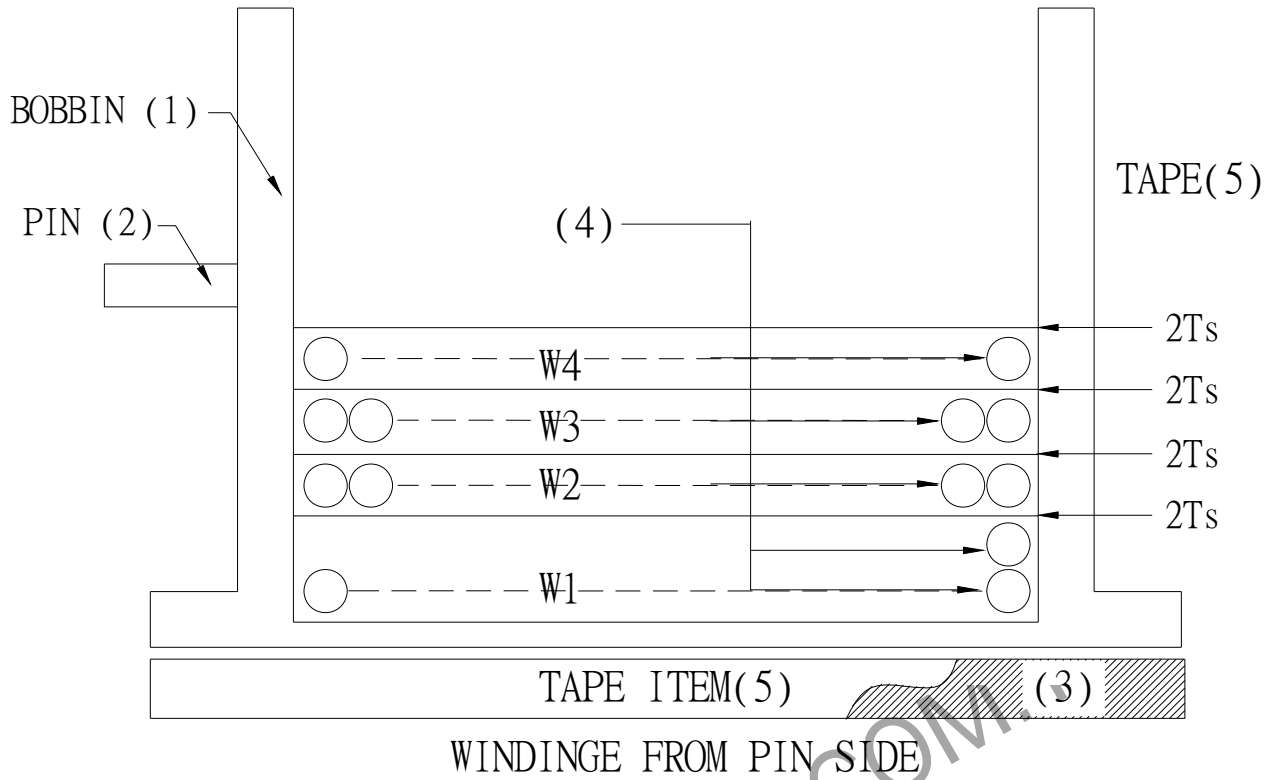

5. SCHEMATIC:

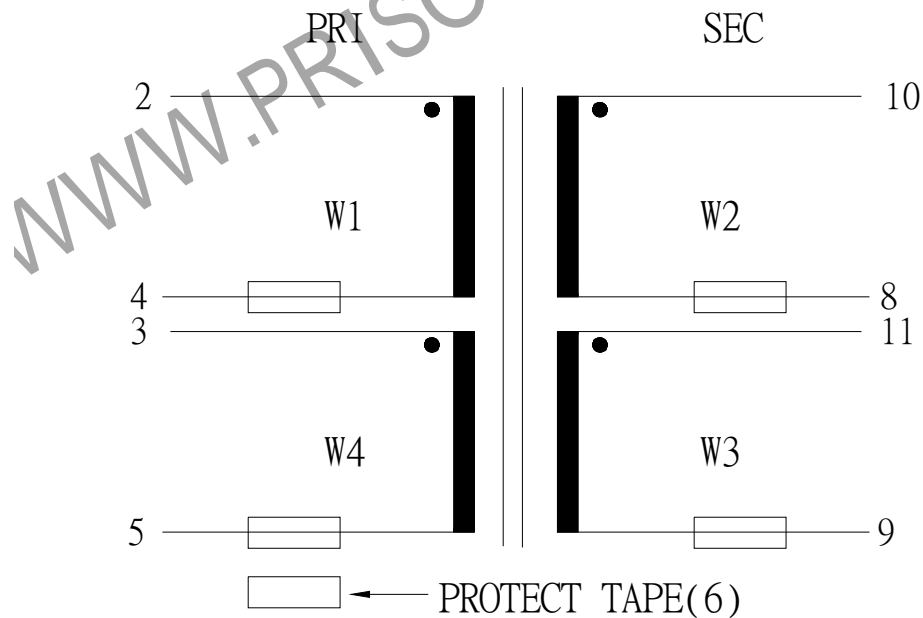

REPORT BY	CHECK BY	APPROVED BY	CUSTOMER :	DATE	
			PART NO : 83P-14003	REV NO.	
			ISSUE NO :	PAGE	4 - 3

6. MATERIAL LIST :

NO.	DESCRIPTION	ITEM	MATERIAL	LIST OF SAMPLE	UL NO.	MANUFACTURER
1	BOBBIN	(1)	PHENOLIC (PM-9820) Thickness:0.50mm Min. YW-865	✓	E41429	SUMITOMO
2	PIN	(2)	TINNED C.P WIRE Φ 0.8	✓		YIH HWA WELL FORE
3	CORE	(3)	FERRITE CORE PQ3230 TP4A	✓		TDG
4	COPPER WIRE	(4)	POLYURETHANE(1UEW) TYPYU-130 MW75-C	✓	E197768	HENG YA
5	MYLAR TAPE	(5)	POLYESTER FILM #1318-1 25um (Y)	✓	E17385	3M
6	PROTECT TAPE	(6)	COMPOSITE FILM #44-A	✓	E17385	3M
7	EPOXY		6020H	✓	E229633	WELLS
8	VARNISH		WP-2952F-2G	✓	E72979	HITACHI

REPORT BY	CHECK BY	APPROVED BY	CUSTOMER :	DATE
			PART NO : 83P-14003	REV NO.
			ISSUE NO :	PAGE 4 - 4