

1. MECHANICAL & ASSEMBLY :

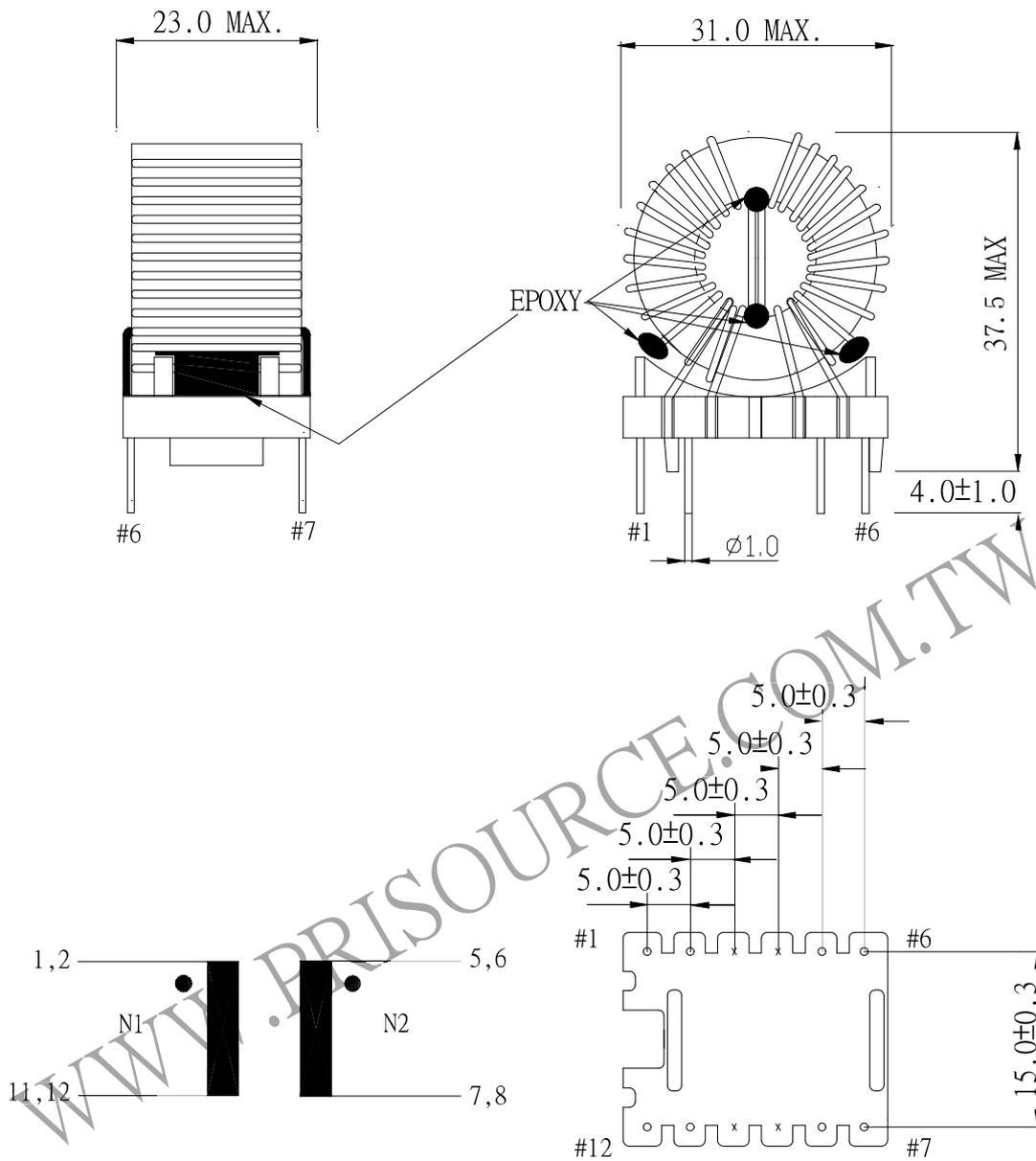

NOTE:

1. EPOXY FIXED BETWEEN SPACER & CORE (TTL:4 POINTS)
2. EPOXY FIXED BETWEEN BASE & CORE (TTL:2 POINTS)
3. PIN 3,4,9,10 NO

UNIT:m/m

REPORT	BY	CHECK	BY	APPROVED	BY	CUSTOMER :	DATE
						PART NO : 83K-13006	REV NO.
						ISSUE NO :	PAGE
							2 - 1