

# 1. MECHANICAL & ASSEMBLY :

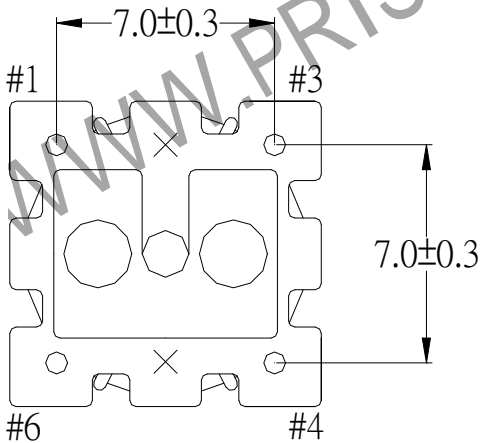

## 2. SCHEMATIC:

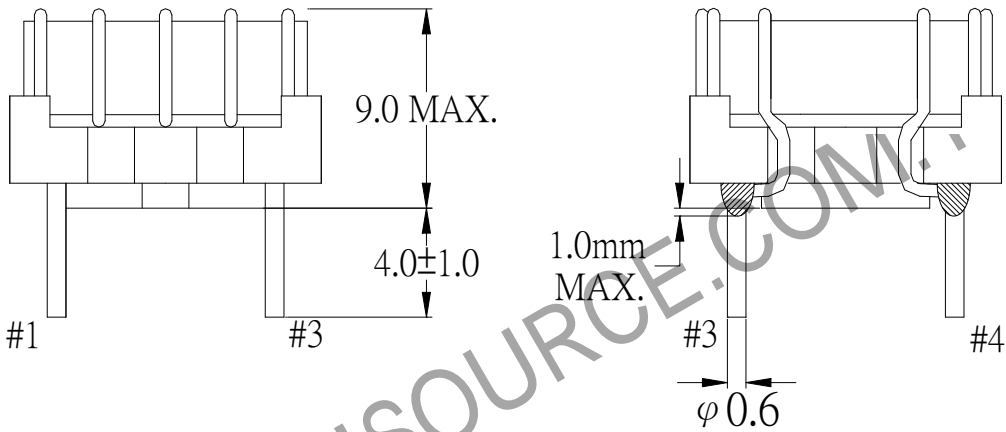
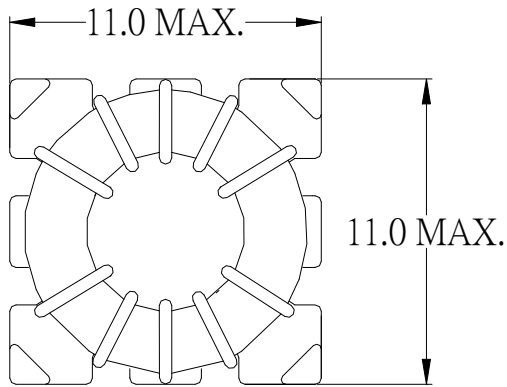
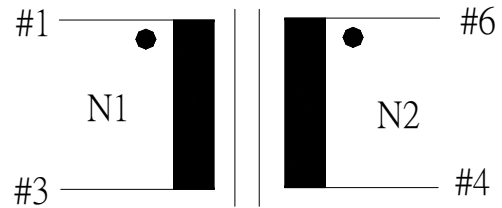

UNIT : mm

NOTE: 1. PIN 2 , PIN 5 NO

2. SOLDER CAN BE OVER BOTTOM OF BASE 1.0mm MAX.

REPORT BY	CHECK BY	APPROVED BY	CUSTOMER :	DATE	
			PART NO : 83F-15002	REV NO.	
			ISSUE NO :	PAGE	3 - 1

## 2. WINDING CONFIGURATION :

STEP	WINDING	MARGIN TAPE	START-FINISH	COPPER WIRE	TURNS	LAYER TAPE	METHOD
1	N1		1 - 3	0.50φ	5Ts		
2	N2		6 - 4	0.50φ	5Ts		

NOTE:

## 3. ELECTRICAL CHARACTERISTICS :

PIN NO.	INDUCTANCE 100 KHz, 0.3Vrms	LEAKAGE INDUCTANCE KHz, Vrms	VOLTAGE RATIO F= 20KHz	DCR MAX. AT 25°C
1 - 3	21.0 uH ± 30%		INPUT 0.1Vrms	10.0 mΩ
6 - 4	21.0 uH ± 30%		0.0990Vrms±4.0%	10.0 mΩ

HI-POT TEST :( AT 1mA, 2 SEC. )

N1 TO N2 1200 VAC

REPORT BY	CHECK BY	APPROVED BY	CUSTOMER :	DATE
			PART NO : 83F-15002	REV NO.
			ISSUE NO :	PAGE 3 - 2

## 6 . MATERIAL LIST :

NO	DESCRIPTION	ITEM	MATERIAL	LIST OF SAMPLE	UL NO.	MANUFACTURE
1	BASE	(1)	PHENOLIC T375HF	√	E59481	CHANG CHUN
2	PIN	(2)	TINNED COPPER WIRE φ0.6mm	√		WELL FORE
3	CORE	(3)	FERRITE CORE  HF70T8×4×4	√		TDK
4	WIRE	(5)	POLYURETHANE (1UEW) TYPU-130 MW75-C	√	E197768	HENG YA

REPORT BY	CHECK BY	APPROVED BY	CUSTOMER :	DATE	
			PART NO : 83F-15002	REV NO.	
			ISSUE NO :	PAGE	3 - 3