

1. MECHANICAL & ASSEMBLY :

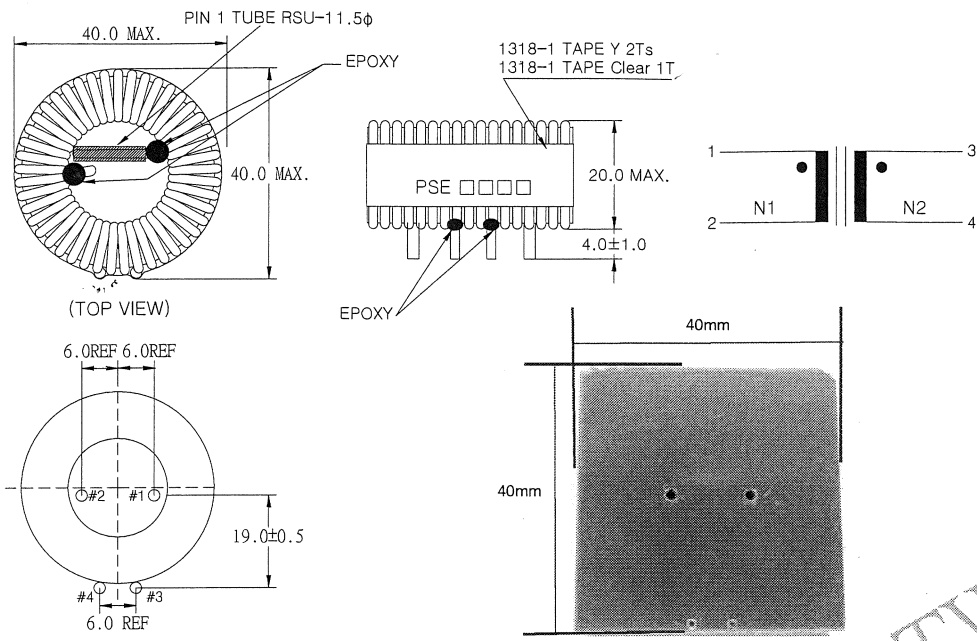

2. WINDING CONFIGURATION:

STEP	WINDING	MARGIN TAPE	START-FINISH	COPPER WIRE	TURN	Turn Layer	Width
1	N1	~	1 - 2	1.3 φ	42Ts		CLOSE
2	N2	~	3 - 4	0.70 φ	5Ts		CLOSE

3. ELECTRICAL CHARACTERISTICS :

PIN NO.	INDUCTANCE 10 KHz, 1.0 V	DC SATURATION KHz, Vrms+DCA	VOLTAGE RATIO(V) f= 20KHz	DCR(MAX.) AT 25°C
1 - 2	25.0uH ±15%		INPVT 0.1Vrms	30.0mΩ
3 - 4			0.0122Vrms±7.0%	14.0mΩ