

## 1. MECHANICAL & ASSEMBLY :

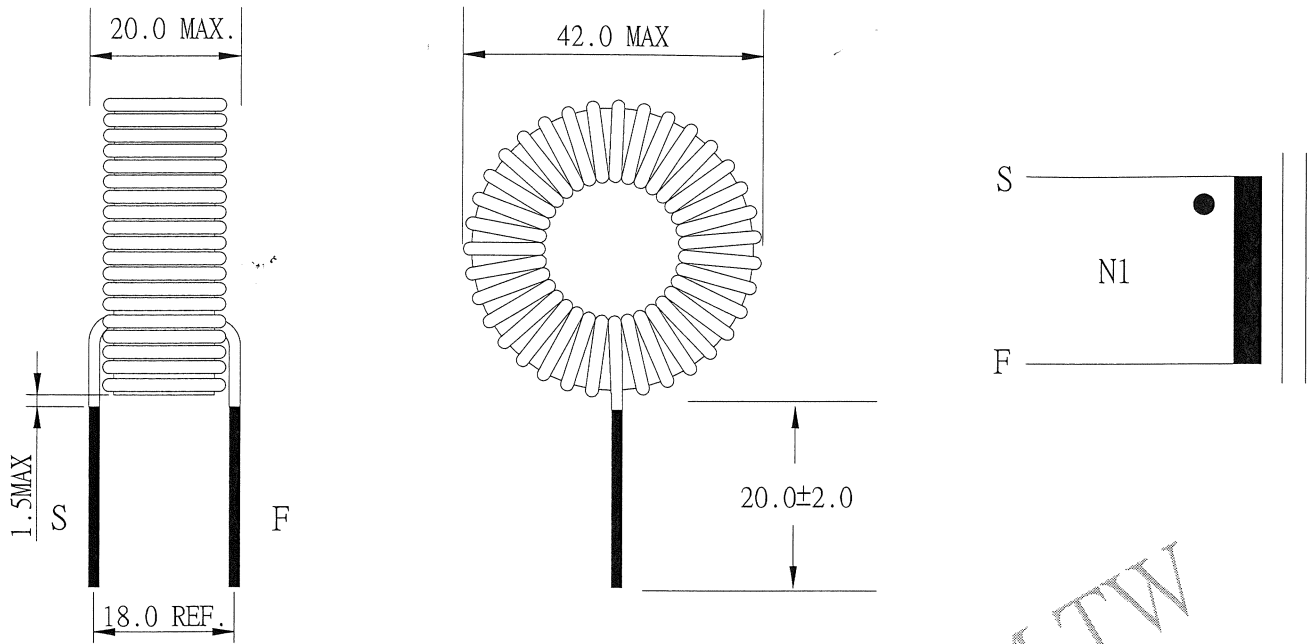

UNIT : mm

## 2. WINDING CONFIGURATION:

STEP	WINDING	MARGIN TAPE	START-FINISH	COPPER WIRE	TURN	LAYER TAPE	METHOD
1	N1		S - F	1.3 $\phi$	68Ts REF.		

## 3. ELECTRICAL CHARACTERISTICS:

PIN NO.	INDUCTANCE 20.0 KHz, 1.0 V	INDUCTANCE 20KHz, 1.0Vrms+DC7.0A	DCR(MAX.) AT 25°C
S - F	280.0uH $\pm$ 25%	245.0uH $\pm$ 25%.	50.0 m $\Omega$