

1. MECHANICAL & ASSEMBLY :

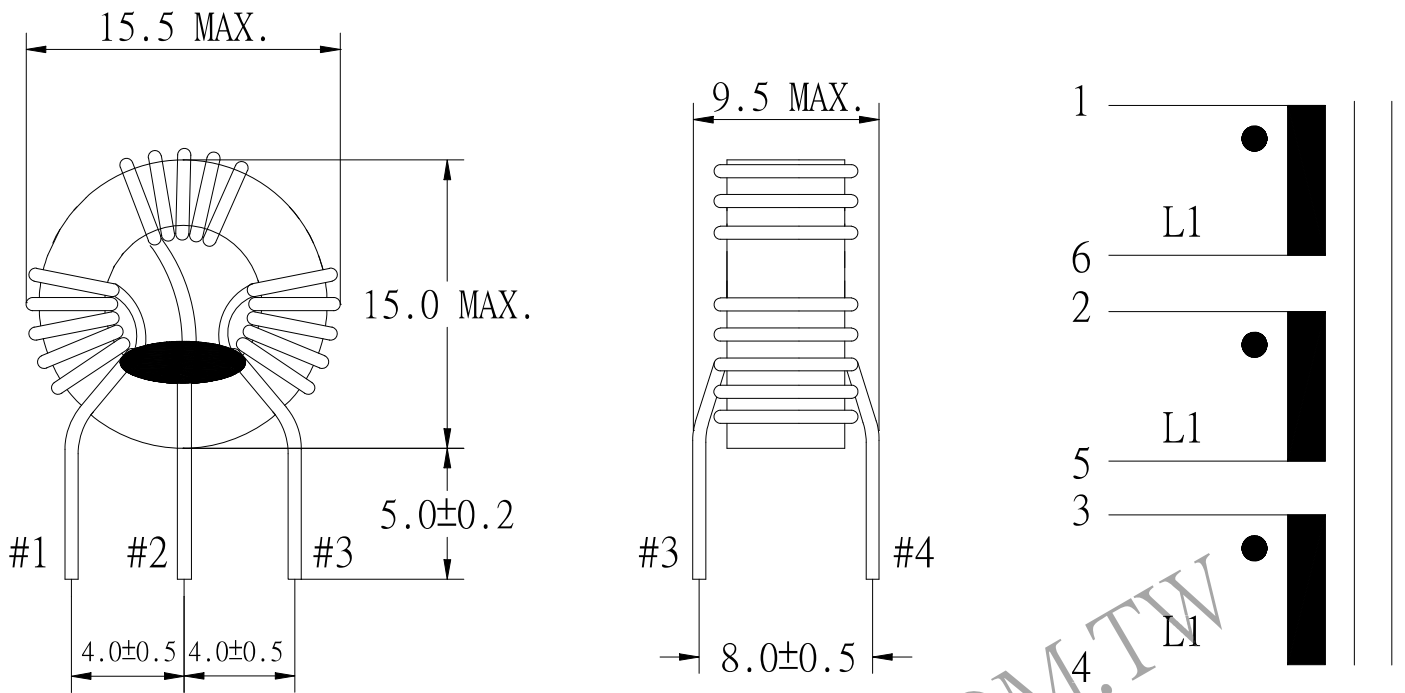

UNIT:m/m

2. WINDING CONFIGURATION:

STEP	WINDING	MARGIN TAPE	START-FINISH	COPPER WIRE	TURN	METHOD	TUBE
1	L1		1 - 6	0.65 φ	6Ts REF.	CLOSE	
2	L2		2 - 5	0.65 φ	6Ts REF.	CLOSE	
3	L3		3 - 4	0.65 φ	6Ts REF.	CLOSE	

REPORT BY	CHECK BY	APPROVED BY	CUSTOMER :	DATE	
			PART NO : 82K-14013	REV NO.	
			ISSUE NO :	PAGE	2 - 1