

1. MECHANICAL & ASSEMBLY :

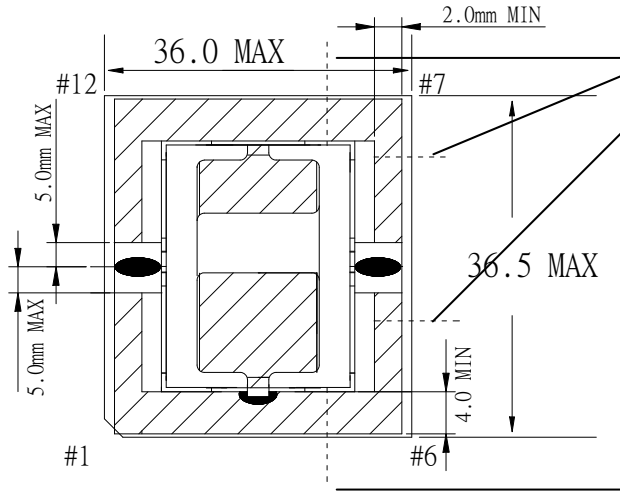

<断面図>

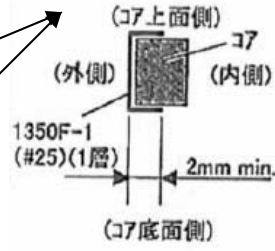

<断面図>

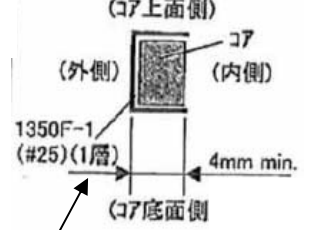

CORE TAPE 3Ts

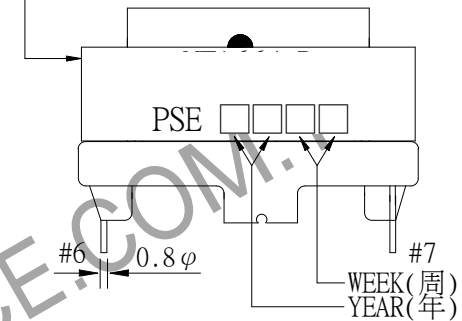
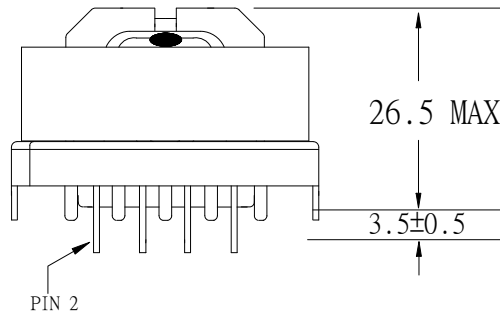

NOTE:

1. EPOXY FIXED BETWEEN CORE & CORE (TTL:2 POINTS)
2. EPOXY FIXED TOP OF BOBBIN & CASE & CORE.(ONE POINT AT PIN1-6 SIDE).
3. PIN 1,6 NO.
4. 「この治具に容易に挿入出来る事」

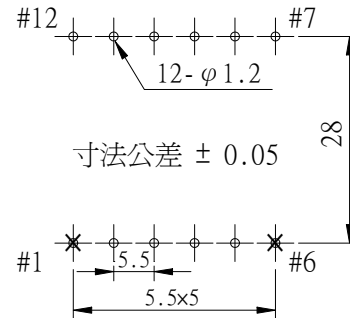
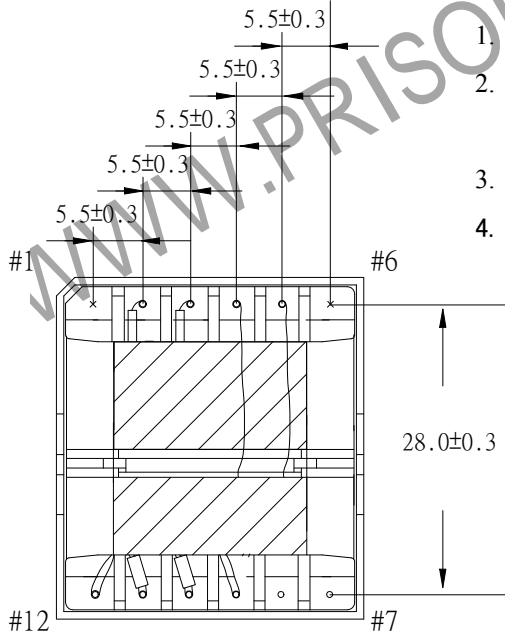

UNIT: m/ m

REPORT BY	CHECK BY	APPROVED BY	CUSTOMER :	DATE
			PART NO : 81P-16010	REV NO.
			ISSUE NO :	PAGE 4 - 1

2. WINDING CONFIGURATION :

STEP	WINDING	MARGIN TAPE	START-FINISH	COPPER WIRE	TURNS	LAYER TAPE	TUBE	METHOD
1	P1		2 - 3	0.10φ/40C	34	1T/1T/1T/3Ts	#16/#16	CLOSE
2	S1		10 - 12	0.10φ/100C	2	1T	#12/~	BIFILAR, CLOSE
3	S2		11 - 9	0.10φ/100C	2		#12/~	
4	S1'		10 - 12	0.10φ/100C	2	1T	#12/~	BIFILAR, CLOSE
5	S2'		11 - 9	0.10φ/100C	2		#12/~	
6	P2		5 - 4	TEX-E 0.3φ	3	3Ts		CLOSE Center

NOTE:1.P1:0.10φ/40C (50Ts 以上/M)

2.S1,S2,S1',S2':0.10φ/100C (45Ts 以上/M)

3.S1&S2 twisted spec:5Ts 以上/20cm

4.S1' & S2' twisted spec:5Ts 以上/20cm

3. ELECTRICAL CHARACTERISTICS :

PIN NO.	INDUCTANCE 10.0KHz, 1.0Vrms	LEAKAGE INDUCTANCE 10 KHZ, 1V	VOLTAGE RATIO(V) f= 20KHz	DCR (MAX) AT 25°C
2 - 3	602.0uH+10%-15%	105.0uH MAX	INPUT 1Vrms	120.0mΩ
10 - 12		SHORT	0.0559V±5.0%	2.5 mΩ
11 - 9		SHORT	0.0559V±5.0%	2.0 mΩ
5 - 4			0.0841V±5.0%	75.0 mΩ

HI-POT TEST : (AT 1 mA, 2 SEC)

PRI. TO SEC. 4800 VAC

PRI. TO CORE. 4800 VAC

SEC. TO CORE. 720 VAC

INSULATION RESISTANCE: (AT DC500V)

PRI. TO SEC. 100 MΩ MIN.

PRI. TO CORE. 100 MΩ MIN.

SEC. TO CORE. 100 MΩ MIN.

REPORT BY	CHECK BY	APPROVED BY	CUSTOMER :	DATE	
			PART NO : 81P-16010	REV NO.	
			ISSUE NO :	PAGE	4 - 2

4. WINDING SEQUENCE:

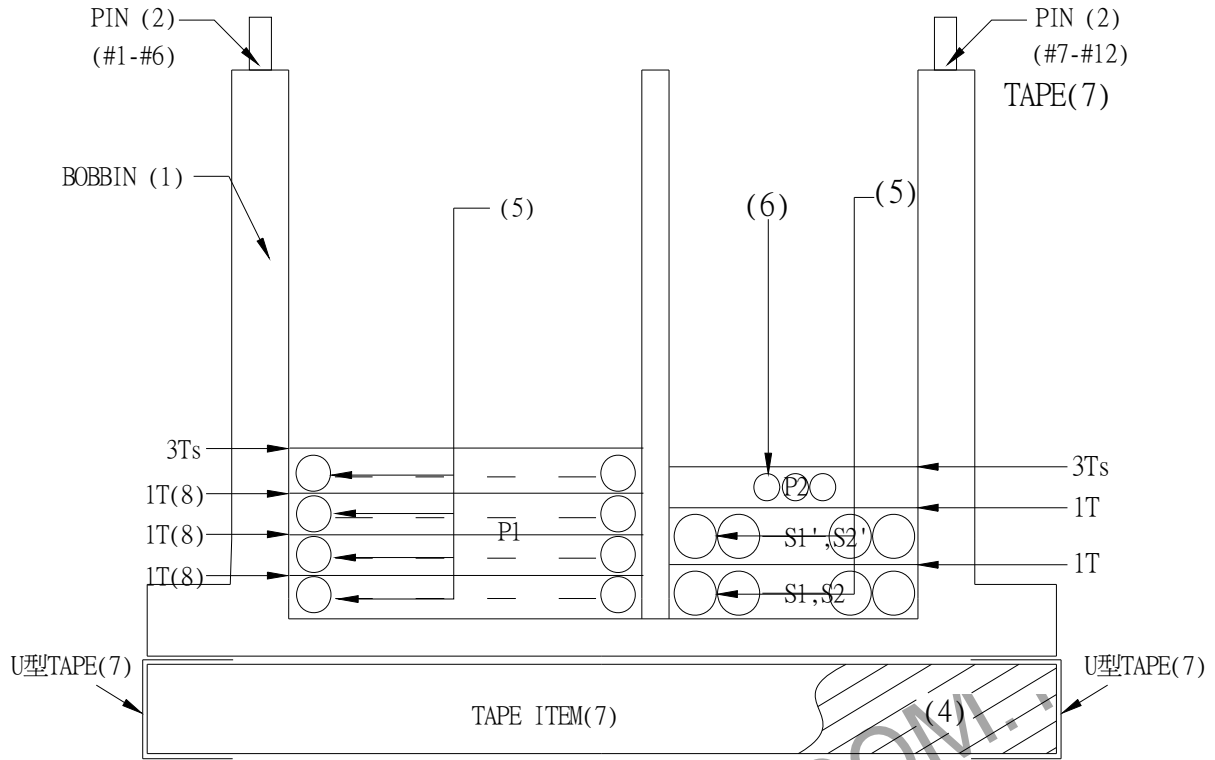

5. SCHEMATIC:

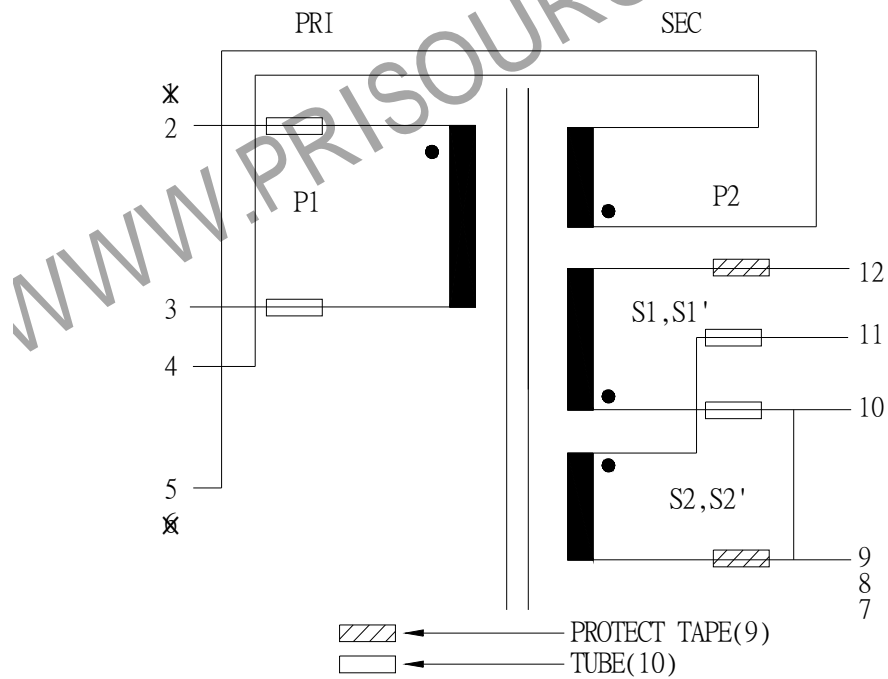

REPORT BY	CHECK BY	APPROVED BY	CUSTOMER :	DATE	
			PART NO : 81P-16010	REV NO.	
			ISSUE NO :	PAGE	4 - 3

6. MATERIAL LIST :

NO.	DESCRIPTION	ITEM	MATERIAL	LIST OF SAMPLE	UL NO.	MANUFACTURER
1	BOBBIN	(1)	PHENOLIC(PM9820) Thickness:0.71mm Min.	✓	E41429	SUMITOMO
2	CASE	(2)	PET FR530 Thickness:0.75mm Min.	✓	E41938	E I DUPONT
3	PIN	(3)	TINNED C.P WIRE φ 0.8	✓		WELL FORE
4	CORE	(4)	FERRITE CORE ETD34 TP4A	✓		TDG
5	COPPER WIRE	(5)	POLYURETHANE(1UEW) TYPU-130 MW75C	✓	E197768	HENG YA
6	TRIPLE WIRE	(6)	TEX-E	✓	E206440	FURUKAWA
7	MYLAR TAPE	(7) (8)	POLYESTER FILM #1350F-1 #1350E-2 COLOR:YELLOW	✓	E17385	3M
8	PROTECT TAPE	(9)	COMPOSITE FILM #44	✓	E17385	3M
9	TUBE	(10)	TEFLON TUBE TFL	✓	E156256	GREAT HOLDING
10	EPOXY		6020H	✓	E229633	WELLS
11	VARNISH		TVB2180T	✓	E83702	KYOCERA

REPORT BY	CHECK BY	APPROVED BY	CUSTOMER :	DATE	
			PART NO : 81P-16010	REV NO.	
			ISSUE NO :	PAGE	4 - 4