

1. MECHANICAL & ASSEMBLY : NOTE:

1. PIN 6 NO.
2. EPOXY FIXED BETWEEN CORE & CORE (TTL:2 POINTS)
3. EPOXY FIXED TOP OF BOBBIN & CORE.(ONE POINT AT PIN 1-7 SIDE).

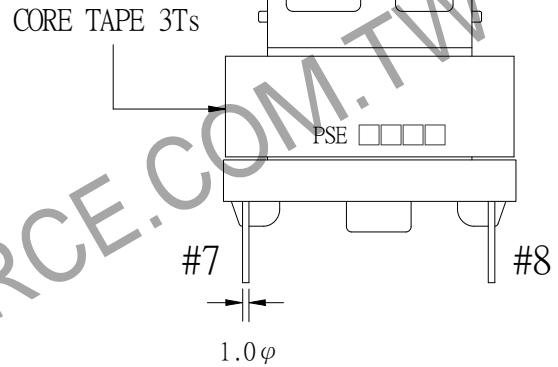

以下の治具に容易に挿入できること。

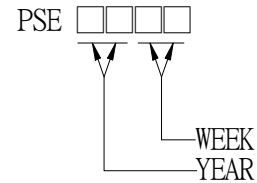
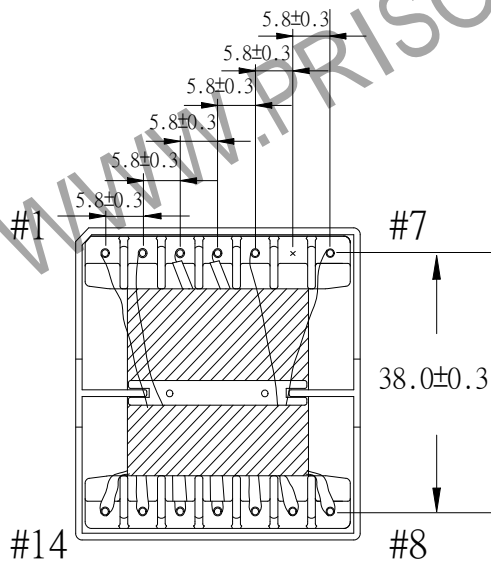
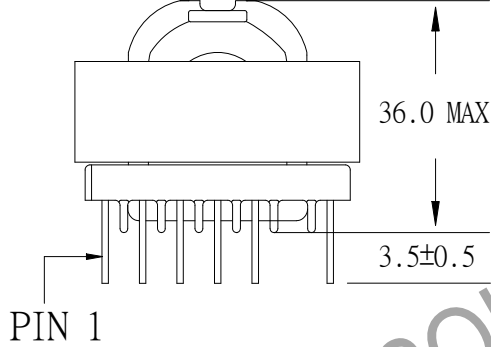
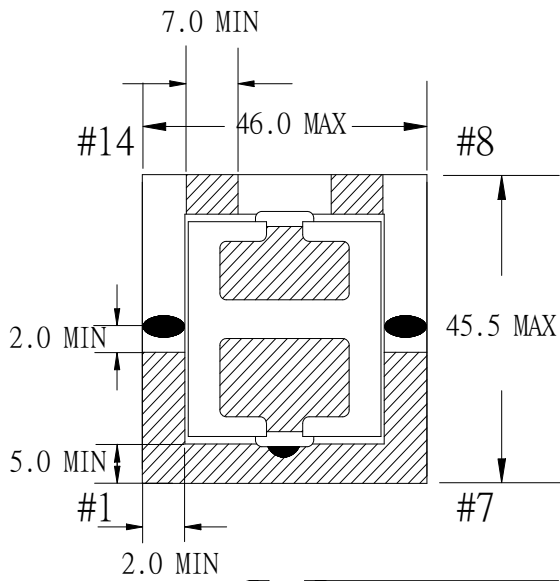
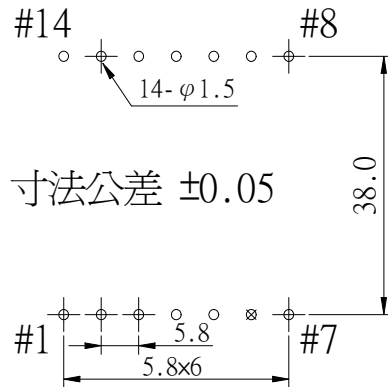

UNIT : m/ m

REPORT BY	CHECK BY	APPROVED BY	CUSTOMER :	DATE
			PART NO : 81P-16006	REV NO.
			ISSUE NO :	PAGE 4 - 1

2. WINDING CONFIGURATION :

STEP	WINDING	MARGIN TAPE	START-FINISH	COPPER WIRE	TURNS	LAYER TAPE	TUBE	METHOD
1	P1		3 - 4	0.10 ϕ /80C	35	1T/1T/1T/3Ts	#14/#14	CLOSE
2	S1		11,12 - 8,9	0.10 ϕ /250C	5	1T	#12	BIFILAR, CLOSE
3	S2		9,10-13,14	0.10 ϕ /250C	5			
4	P3	~/1.5mm \times 1T	2 - 1	TEX-E 0.30 ϕ	1	1PC		CENTER CLOSE
5	P2		7 - 5	TEX-E 0.30 ϕ	3	3Ts		SPACE

NOTE:

3. ELECTRICAL CHARACTERISTICS :

PIN NO.	INDUCTANCE 1.0 KHz, 1.0V _{rms}	LEAKAGE INDUCTANCE 1.0 KHz, 1.0V _{rms}	VOLTAGE RATIO(V) f= 20KHz	DCR MAX. AT 25°C
3 - 4	403.0 μ H \pm 10%	100.0 μ H \pm 10%	INPUT 1V _{rms}	85.0 m Ω
11,12 - 8,9		SHORT	0.1261V _{rms} \pm 4.0%	5.5 m Ω
9,10 - 13,14		SHORT	0.1264V _{rms} \pm 4.0%	5.5 m Ω
2 - 1			0.0254V _{rms} \pm 7.0%	50.0 m Ω
7 - 5			0.0763V _{rms} \pm 5.0%	100.0 m Ω

HI-POT TEST : (AT 1 mA, 2 SEC)

PRI	TO	SEC	4800 VAC
PRI	TO	CORE	4800 VAC
SEC	TO	CORE	2160 VAC

INSULATION RESISTANCE: (AT DC 500V)

PRI	TO	SEC	100 M Ω MIN.
PRI	TO	CORE	100 M Ω MIN.
SEC	TO	CORE	100 M Ω MIN.

INPULSE TEST :1200V -P(3 - 4)

REPORT	BY	CHECK	BY	APPROVED	CUSTOMER :	DATE	
					PART NO : 81P-16006	REV NO.	
					ISSUE NO :	PAGE	4 - 2

4. WINDING SEQUENCE:

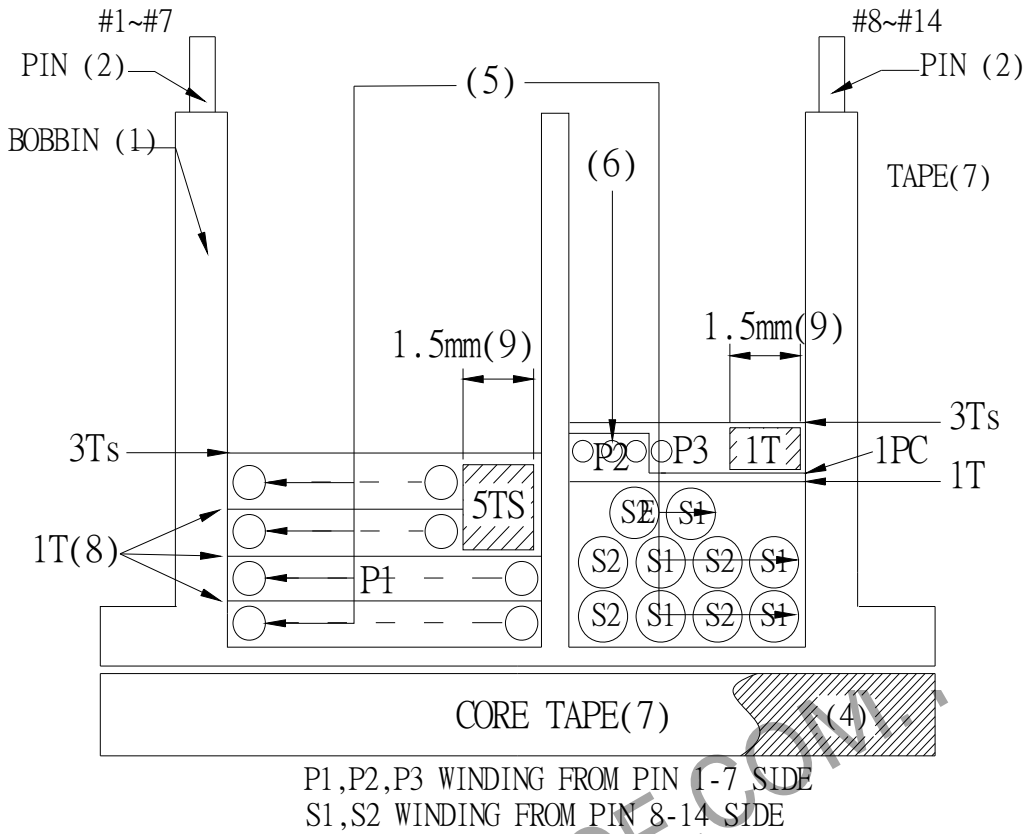

5. SCHEMATIC:

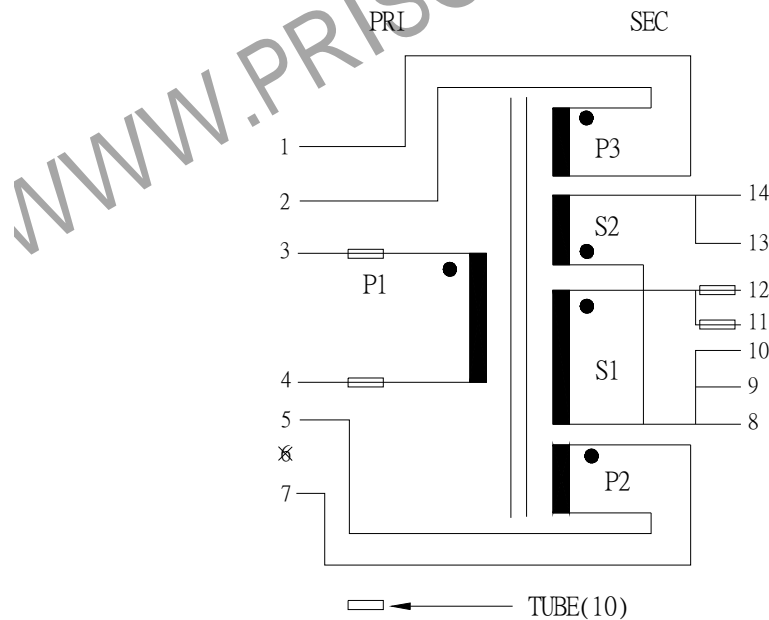

REPORT BY	CHECK BY	APPROVED BY	CUSTOMER :	DATE
			PART NO : 81P-16006	REV NO.
			ISSUE NO :	PAGE 4 - 3

6 . MATERIALS LIST :

NO	DESCRIPTION	ITEM	MATERIAL	LIST OF SAMPLE	UL NO.	MANUFACTURE
1	BOBBIN	(1)	PHENOLIC (PM9820) Thickness:0.71mm Min. ETD-4412	√	E42956	HITACHI HO JINN
2	PIN	(2)	TINNED C.P WIRE φ1.0	√		WELL FORE
3	CASE	(3)	PET FR530 Thickness:0.45mm Min. ETD-4412-1	√	E41938	E I DUPONT
4	CORE	(4)	FERRITE CORE ETD44/45/15 TP4A	√		TDG
5	COPPER WIRE	(5)	POLYURETHANE (1UEW,2UEW) TYPU-130 MW75-C	√	E197768	HENG YA
		(6)	TEX-E	√	E206440	FURUKAWA
6	MYLAR TAPE	(7)	POLYESTER FILM #1350F-1	√	E17385	3M
		(8)	#1350F-2 COLOR:YELLOW			
7	MARGIN TAPE	(9)	COMPOSITE FILM #44T-A	√	E17385	3M
8	TUBE	(10)	TEFLON TUBE TFL	√	E156256	GREAT HOLDING
9	EPOXY		6020H	√	E229633	WELLS
10	VARNISH		TVB2180T	√	E83702	KYOCERA

REPORT BY	CHECK BY	APPROVED BY	CUSTOMER :	DATE
			PART NO : 81P-16006	REV NO.
			ISSUE NO :	PAGE 4 - 4