

# 1. MECHANICAL & ASSEMBLY :

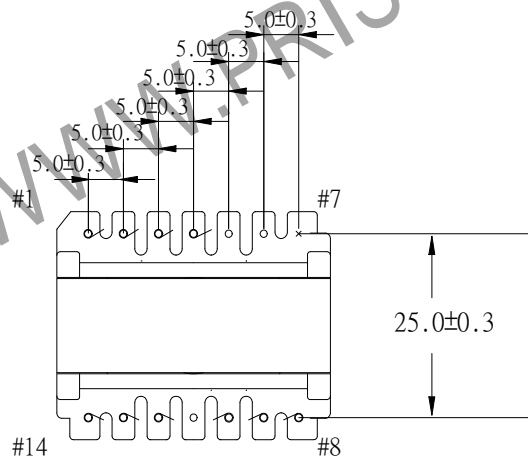
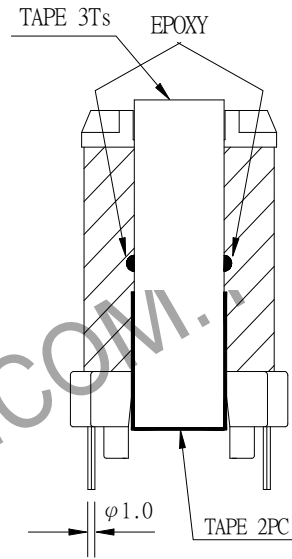
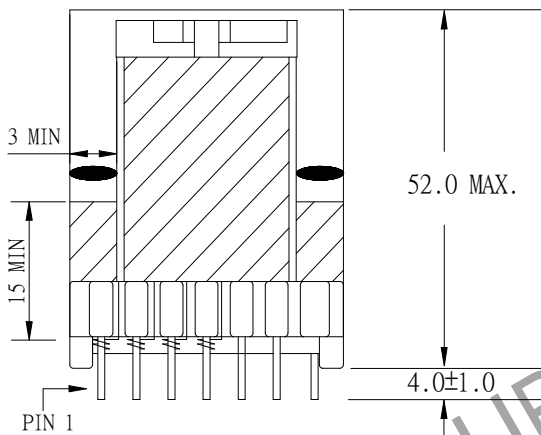
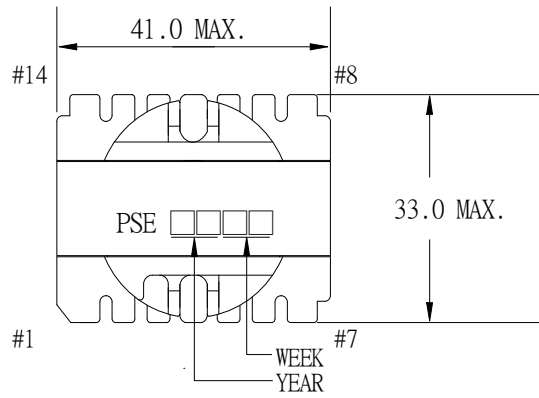

## NOTE:

1. EPOXY FIXED BETWEEN CORE & CORE (TTL:4 POINTS) EPOXY FIXED TOP OF BOBBIN & CORE.(ONE POINT).
2. ADHESIVE EP-138 FIXED BETWEEN CORE & CORE (TTL:2 POINTS)
3. PIN 7 NO.

UNIT:mm

REPORT BY	CHECK BY	APPROVED BY	CUSTOMER :	DATE	
			PART NO : 81P-15012	REV NO.	
			ISSUE NO :	PAGE	4 - 1

## 2. WINDING CONFIGURATION :

STEP	WINDING	MARGIN TAPE	START-FINISH	COPPER WIRE	TURNS	LAYER TAPE	METHOD
1	P1	1.5/1.5mm×4Ts	4 - 3	TEX-E 1.0φ	20	3Ts	CLOSE
2	S1	1.5mm/~×10Ts	8,9,10 - 12,13,14	0.8φ×4	22	3Ts	CLOSE
3	P1'	1.5/1.5mm×4Ts	2 - 1	TEX-E 1.0φ	20	3Ts	CLOSE

NOTE:

## 3. ELECTRICAL CHARACTERISTICS :

PIN NO.	INDUCTANCE 1.0KHz, 1.0Vrms	LEAKAGE INDUCTANCE KHz, Vrms	VOLTAGE RATIO(V) F= 20KHz	DCR MAX. AT 25°C
4 - 1	2.68mH MIN			
4 - 3			INPUT 1Vrms	30.0 mΩ
8,9,10 -12,13,14			1.1000 Vrms±3.0%	16.0 mΩ
2 - 1			1.0000 Vrms±3.0%	45.0 mΩ
3 - 2	SHORT			

HI-POT TEST :(AT 1mA, 2 SEC.)

PRI. TO SEC. 3960 VAC

PRI TO CORE 3960 VAC

INSULATION RESISTANCE:(AT DC 500V)

PRI. TO SEC. 100 MΩ MIN.

PRI. TO CORE. 100 MΩ MIN.

REPORT BY	CHECK BY	APPROVED BY	CUSTOMER :	DATE
			PART NO : 81P-15012	REV NO.
			ISSUE NO :	PAGE 4 - 2

#### 4. WINDING SEQUENCE:

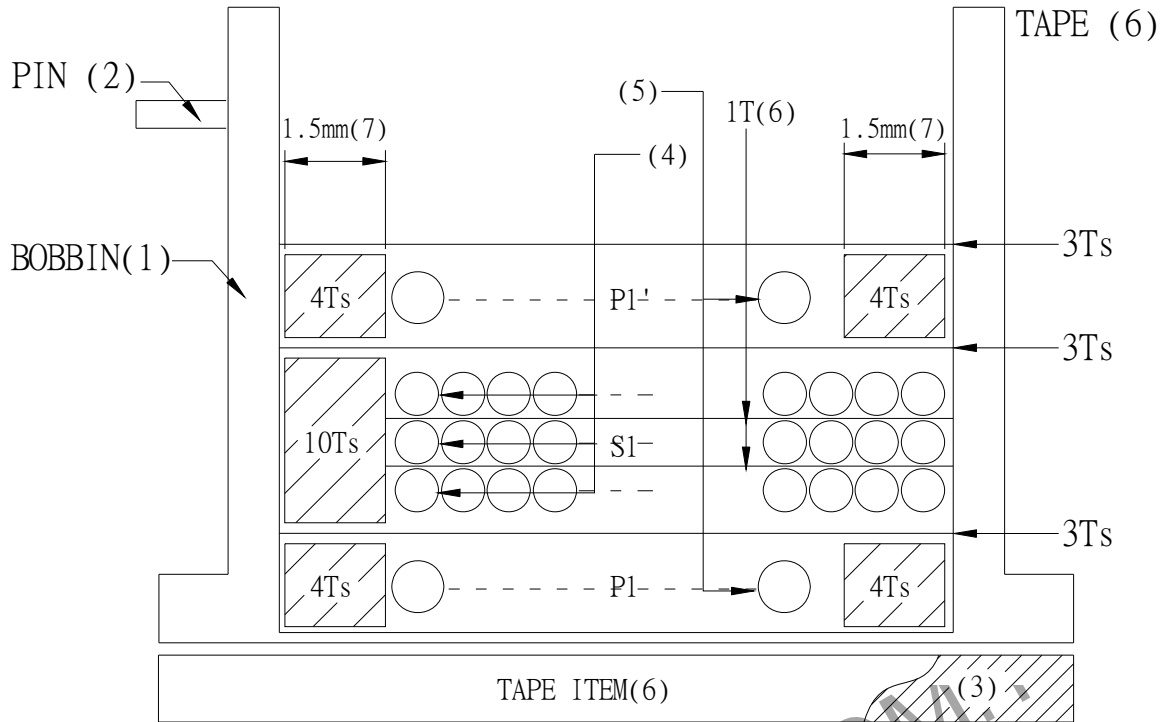

ALL WINDING FROM PIN SIDE

#### 5. SCHEMATIC:

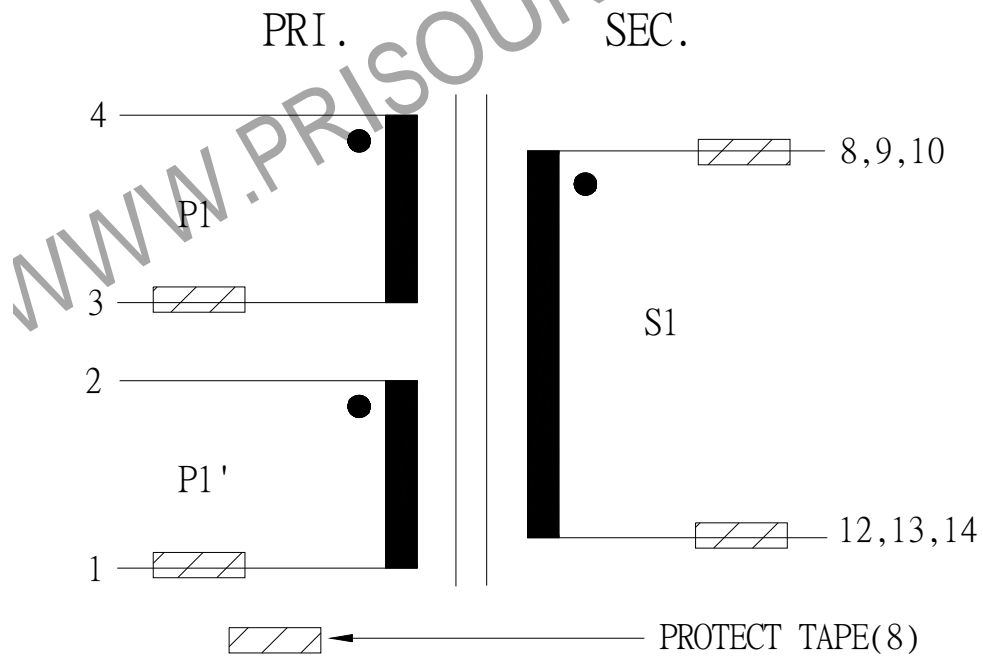

REPORT BY	CHECK BY	APPROVED BY	CUSTOMER :	DATE	
			PART NO : 81P-15012	REV NO.	
			ISSUE NO :	PAGE	4 - 3

6 . MATERIAL LIST :

NO	DESCRIPTION	ITEM	MATERIAL	LIST OF SAMPLE	UL NO.	MANUFACTURE
1	BOBBIN	(1)	PHENOLIC (T375J) Thickness:0.80 mm Min.	√	E59481	CHANG CHUN
2	PIN	(2)	TINNED COPPER WIRE φ 1.0	√		WELL FORE
3	CORE	(3)	FERRITE CORE  EER39/44 TP4	√		TDG
4	COPPER WIRE	(4)	POLYURETHANE(1UEW) MW75-C TYPYU-130	√	E197768	HENG YA
5	TRIPLE WIRE	(5)	TEX-E	√	E206440	FURUKAWA
6	MYLAR TAPE	(6)	POLYESTER FILM #1318-1 Y	√	E17385	3M
7	MARGIN TAPE	(7)	COMPOSITE FILM #44T-A	√	E17385	3M
8	PROTECT TAPE	(8)	COMPOSITE FILM #44-A	√	E17385	3M
9	EPOXY		6020H	√	E229633	WELLS
10	VARNISH		TVB2180T	√	E83702	KYOCERA

REPORT BY	CHECK BY	APPROVED BY	CUSTOMER :	DATE	
			PART NO : 81P-15012	REV NO.	
			ISSUE NO :	PAGE	4 - 4