

1. MECHANICAL & ASSEMBLY :

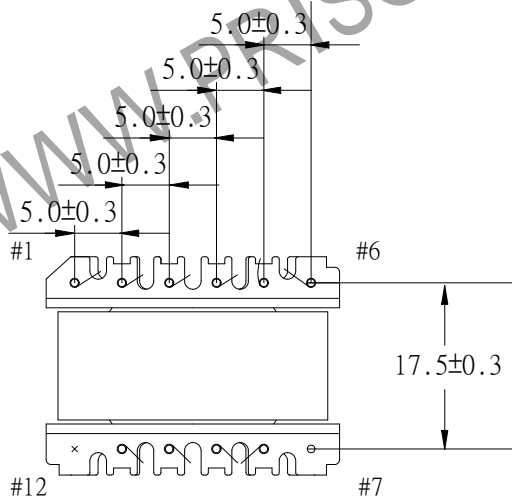
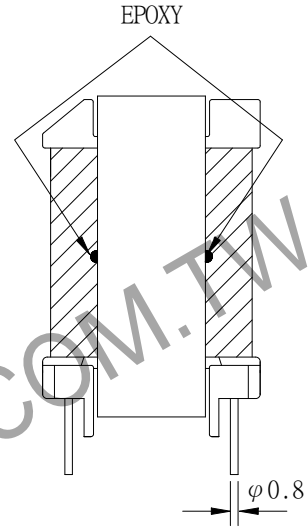
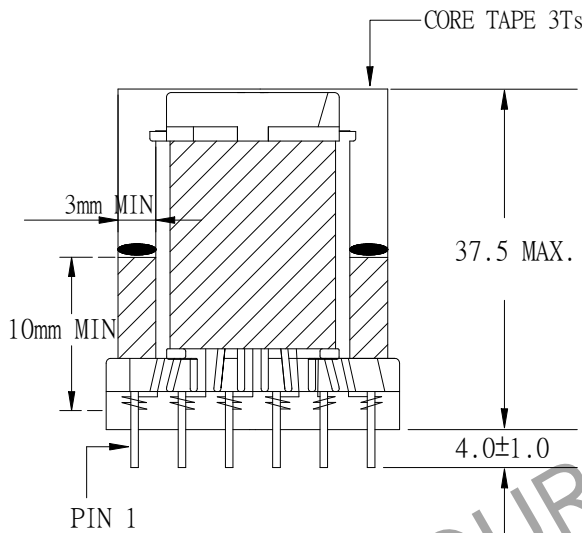
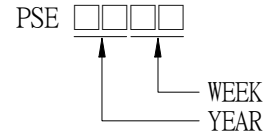
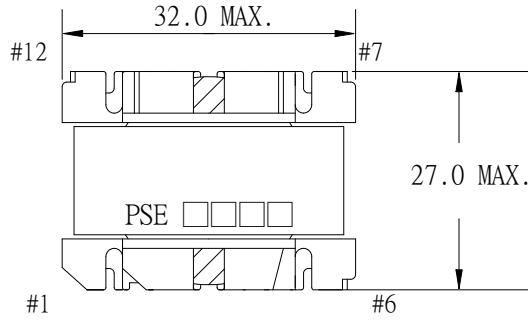

NOTE:

1. EPOXY FIXED BETWEEN CORE & CORE (TTL:4 POINTS).
2. PIN 12 NO.
3. EPOXY FIXED TOP OF BOBBIN & CORE.(ONE POINT).
4. PIN 8 & PIN 9 LEADING WIRE LEAD OUT FROM THE SAME SLOT

UNIT:m/m

REPORT BY	CHECK BY	APPROVED BY	CUSTOMER :	DATE	
			PART NO : 81P-14014	REV NO.	
			ISSUE NO :	PAGE	4 - 1

2. WINDING CONFIGURATION :

STEP	WINDING	MARGIN TAPE	START-FINISH	COPPER WIRE	TURNS	LAYER TAPE	TUBE	METHOD
1	P2	1.5mm/1.5mm×1T	5 - 4	TEX-E 0.30φ	34	1T		CLOSE
2	P1	1.5mm/1.5mm×3Ts	3 - 2	TEX-E0.30φ×2	34	1T		CLOSE
3	S1	2.5mm/2.5mm×3Ts	8,9 - 10,11	0.40φ×2	34	1T/1T		CLOSE
4	P1'	1.5mm/1.5mm×3Ts	2 - 1	TEX-E0.30φ×2	34	1T		CLOSE
5	P2'	1.5mm/1.5mm×1T	4 - 6	TEX-E 0.30φ	34	3Ts		CLOSE

NOTE:

3. ELECTRICAL CHARACTERISTICS :

PIN NO.	INDUCTANCE 1.0 KHz, 0.3V _{rms}	LEAKAGE INDUCTANCE KHz, V _{rms}	VOLTAGE RATIO(V) F= 20KHz INPUT 1V _{rms}	DCR MAX. AT 25°C
3 - 1	11.65mH±25%			
5 - 4			0.4970V _{rms} ±4.0%	0.42 Ω
3 - 2			0.4995V _{rms} ±4.0%	230.0mΩ
8,9 - 10,11			0.5000V _{rms} ±3.0%	155.0mΩ
2 - 1			0.5005V _{rms} ±3.0%	0.30 Ω
4 - 6			0.4995V _{rms} ±4.0%	0.64 Ω

HI-POT TEST : (AT 1 mA , 2SEC.)

PRI.	TO	SEC.	3600 VAC
PRI.	TO	CORE	3600 VAC
SEC.	TO	CORE	1800 VAC

INSULATION RESISTANCE:(AT DC 500V)

PRI.	TO	SEC.	100 MΩ MIN.
PRI.	TO	CORE.	100 MΩ MIN.
SEC.	TO	CORE.	100 MΩ MIN.

REPORT BY	CHECK BY	APPROVED BY	CUSTOMER :	DATE	
			PART NO : 81P-14014	REV NO.	
			ISSUE NO :	PAGE	4 - 2

4. WINDING SEQUENCE:

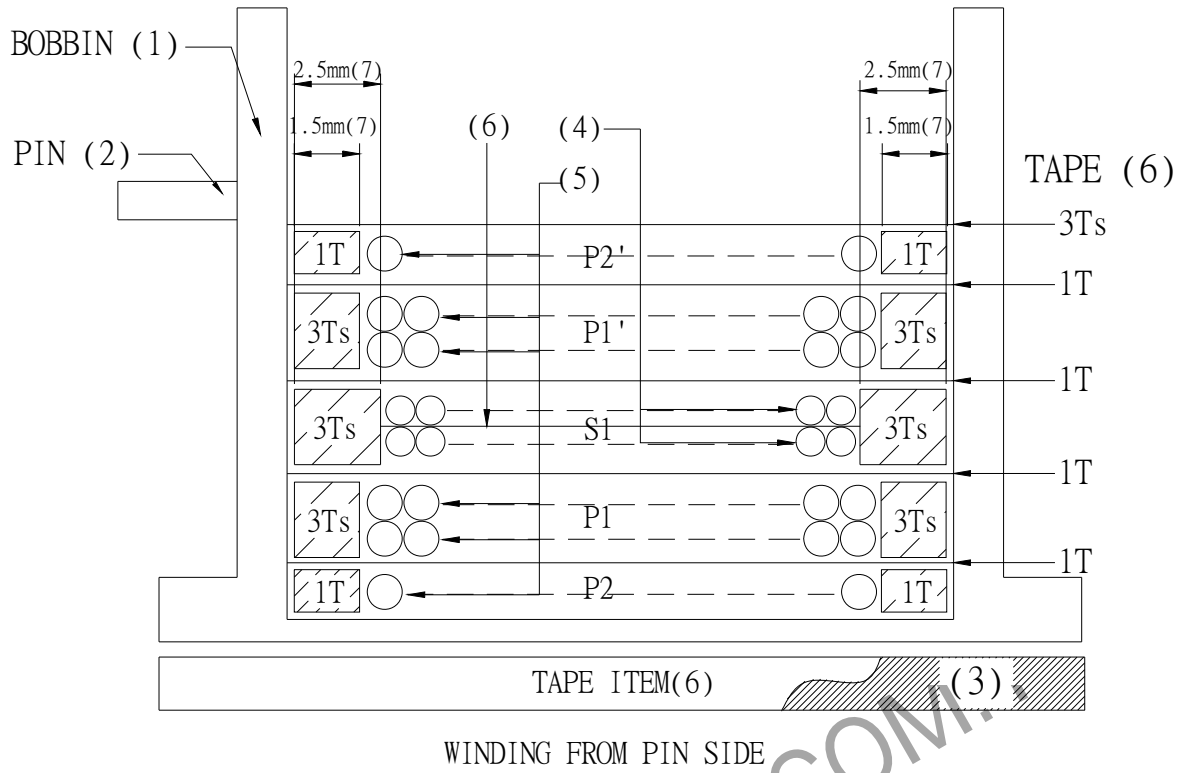

5. SCHEMATIC:

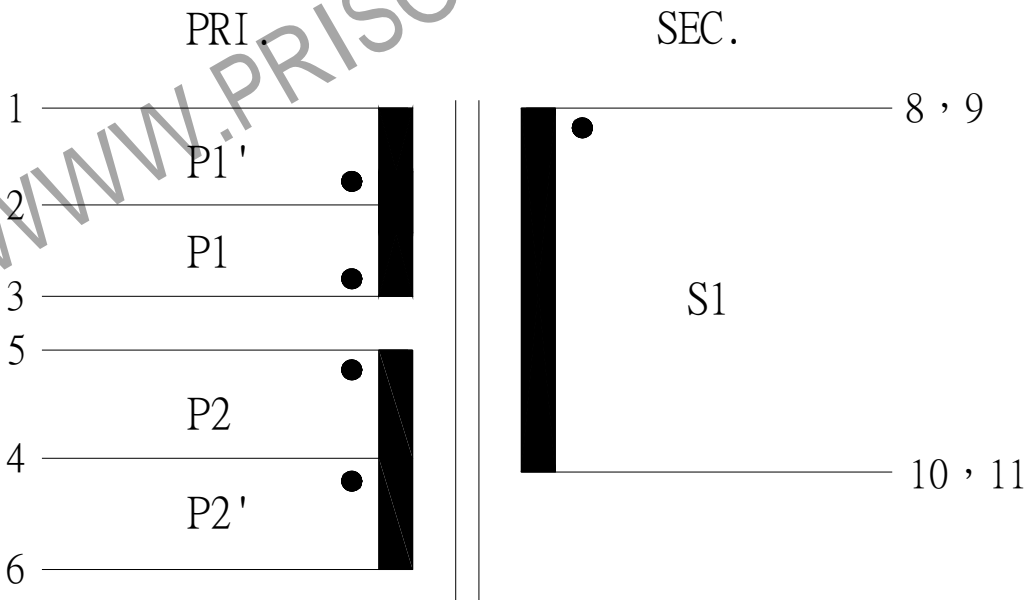

REPORT BY	CHECK	APPROVED BY	CUSTOMER :	DATE	
			PART NO : 81P-14014	REV NO.	
			ISSUE NO :	PAGE	4 - 3

6. MATERIAL LIST :

NO.	DESCRIPTION	ITEM	MATERIAL	LIST OF SAMPLE	UL NO.	MANUFACTURER
1	BOBBIN	(1)	PHENOLIC (PM9820) Thickness:0.71mm Min.	✓	E41429	SUMITOMO
2	PIN	(2)	TINNED C.P WIRE Φ 0.8	✓		WELL FORE
3	CORE	(3)	FERRITE CORE EER-28.5B TP4	✓		TDG
4	COPPER WIRE	(4)	POLYURETHANE(1UEW) TYPU-130 MW75-C	✓	E197768	HENG YA
5	TRIPLE WIRE	(5)	TEX-E	✓	E206440	FURUKAWA
6	MYLAR TAPE	(6)	POLYESTER FILM #1350F-1 (Y) CTI 400 MIN	✓	E17385	3M
7	MARGIN TAPE	(7)	COMPOSITE FILM #44T-A CTI 400 MIN	✓	E17385	3M
8	EPOXY		6020H	✓	E229633	WELLS
9	VARNISH		TVB2180T	✓	E83702	KYOCERA

REPORT BY	CHECK BY	APPROVED BY	CUSTOMER :	DATE	
			PART NO : 81P-14014	REV NO.	
			ISSUE NO :	PAGE	4 - 4