

1. MECHANICAL & ASSEMBLY :

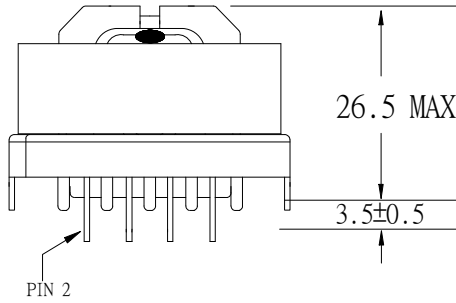

CORE TAPE 3Ts

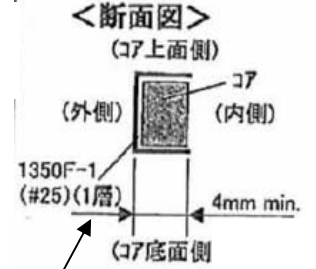
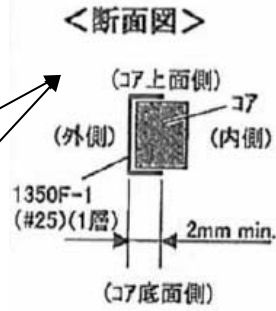
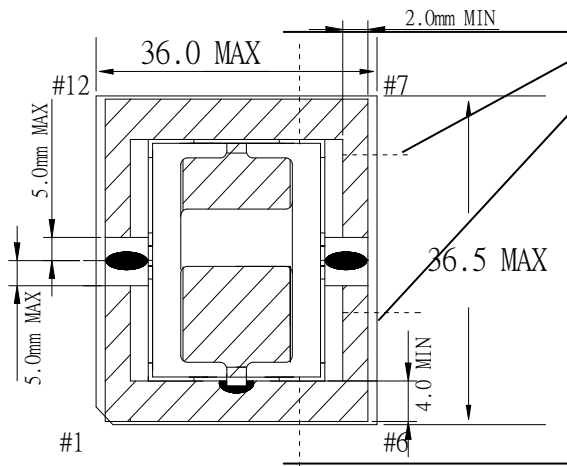
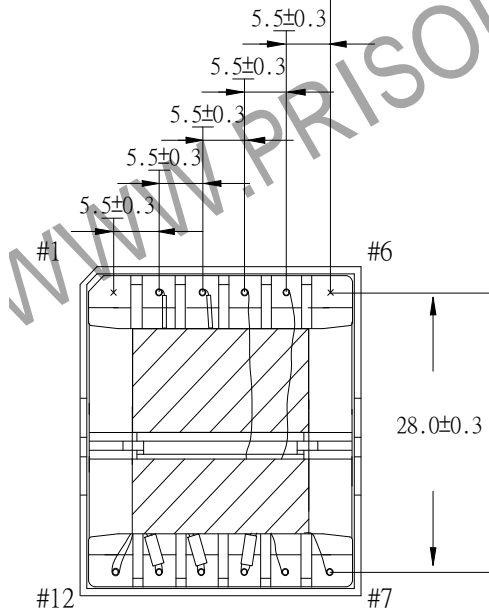
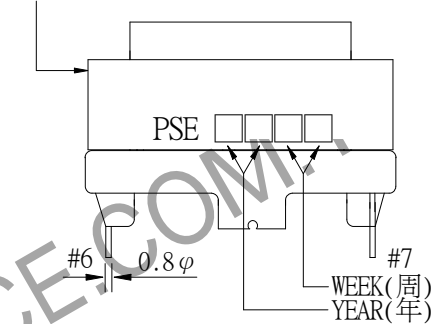

NOTE:

1. EPOXY FIXED BETWEEN CORE & CORE (TTL:2 POINTS)
2. EPOXY FIXED TOP OF BOBBIN & CASE & CORE.(ONE POINT AT PIN1-6 SIDE).
3. PIN 1,6 NO.

UNIT: m/ m

REPORT BY	CHECK BY	APPROVED BY	CUSTOMER :	DATE
			PART NO : 81P-14005	REV NO.
			ISSUE NO :	PAGE 4 - 1

2. WINDING CONFIGURATION:

STEP	WINDING	MARGIN TAPE	START-FINISH	COPPER WIRE	TURNS	LAYER TAPE	TUBE	METHOD
1	P1		2 - 3	TIW-2 LZ 0.1 ϕ /27	35	2Ts	#18/#18	CLOSE
2	S1		10 - 12	0.10 ϕ /100C	4	1T	#12/~	BIFILAR,
3	S2		11 - 9	0.10 ϕ /100C	4		#12/#12	CLOSE
4	S3		8 - 7	TEX-E 0.3 ϕ	2	1T		SPACE
5	P2		5 - 4	TEX-E 0.3 ϕ	3	3Ts		CLOSE Center

NOTE:

3. ELECTRICAL CHARACTERISTICS:

PIN NO.	INDUCTANCE 1.0KHz, 1.0Vrms	LEAKAGE INDUCTANCE 1KHZ, 1V	VOLTAGE RATIO(V) f= 20KHz	DCR (MAX) AT 25°C
2 - 3	592.0uH \pm 10.0%	79.5uH \pm 10.0%	INPUT 1Vrms	185.0m Ω
10 - 12		SHORT	0.1090V \pm 4.0%	7.0 m Ω
11 - 9		SHORT	0.1090V \pm 4.0%	7.0 m Ω
8 - 7		SHORT	0.0545V \pm 3.0%	45.0 m Ω
5 - 4			0.0820V \pm 3.0%	75.0 m Ω

HI-POT TEST : (AT 1 mA, 2 SEC)

PRI.	TO	SEC.	4800 VAC
PRI.	TO	CORE.	4800 VAC
SEC.	TO	CORE.	720 VAC

INSULATION RESISTANCE: (AT DC500V)

PRI.	TO	SEC.	100 M Ω MIN.
PRI.	TO	CORE.	100 M Ω MIN.
SEC.	TO	CORE.	100 M Ω MIN.

REPORT BY	CHECK BY	APPROVED BY	CUSTOMER :	DATE	
			PART NO : 81P-14005	REV NO.	
			ISSUE NO :	PAGE	4 - 2

4. WINDING SEQUENCE:

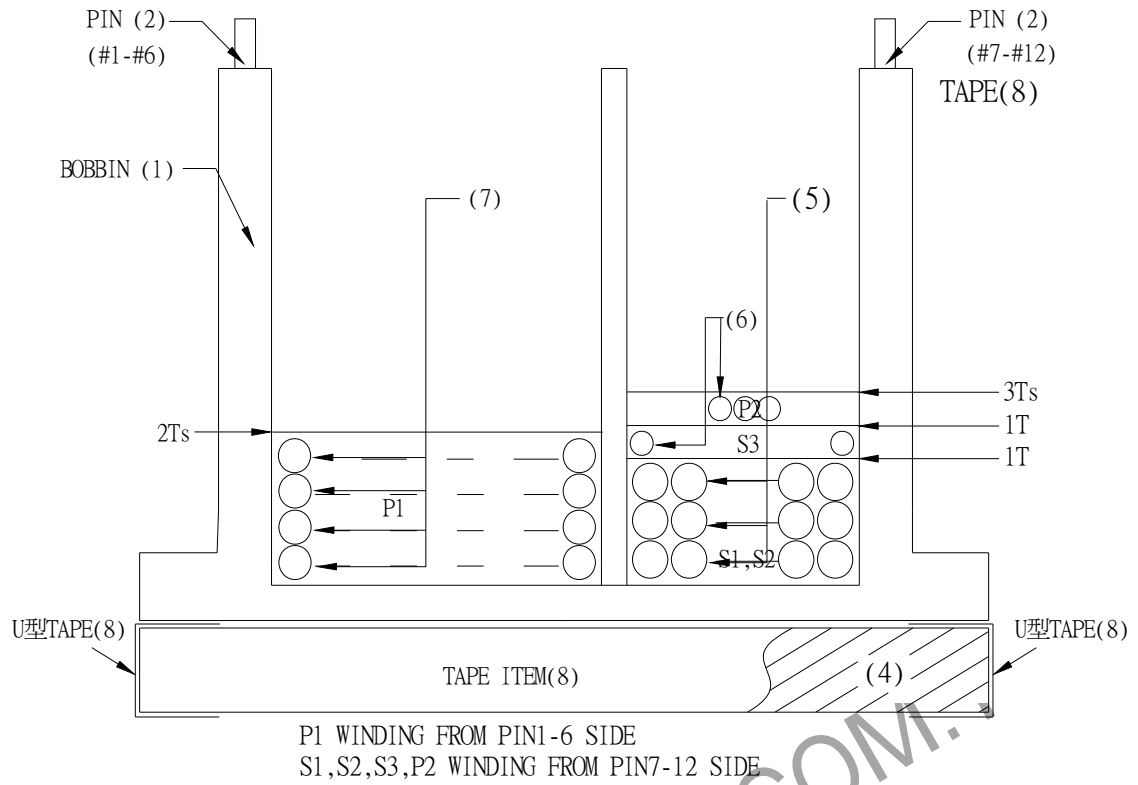

5. SCHEMATIC:

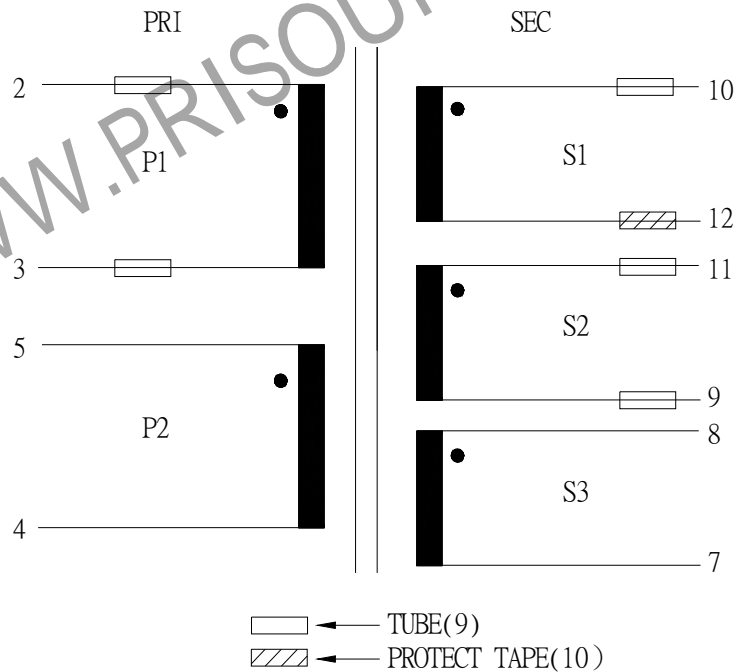

REPORT BY	CHECK BY	APPROVED BY	CUSTOMER :	DATE	
			PART NO : 81P-14005	REV NO.	
			ISSUE NO :	PAGE	4 - 3

6. MATERIAL LIST :

NO.	DESCRIPTION	ITEM	MATERIAL	LIST OF SAMPLE	UL NO.	MANUFACTURER
1	BOBBIN	(1)	PHENOLIC(PM9820) Thickness:0.71mm Min.	✓	E41429	SUMITOMO
2	CASE	(2)	PET FR530 Thickness:0.45mm Min.	✓	E41938	E I DUPONT
3	PIN	(3)	TINNED C.P WIRE φ 0.8	✓		WELL FORE
4	CORE	(4)	FERRITE CORE ETD34 TP4A	✓		TDG
5	COPPER WIRE	(5)	POLYURETHANE(1UEW) TYPYU-130 MW75C 0.10φ/100C (pitch spec 45Ts/m 以上)	✓	E197768	HENG YA
6	TRIPLE WIRE	(6)	TEX-E	✓	E206440	FURUKAWA
		(7)	TIW-2 LZ	✓	E166483	TOTOKU
7	MYLAR TAPE	(8)	POLYESTER FILM #1350F-1 Y	✓	E17385	3M
8	TUBE	(9)	TEFLON TUBE TFL	✓	E156256	GREAT HOLDING
9	PROTECT TAPE	(10)	COMPOSITE FILM #44-A	✓	E17385	3M
10	EPOXY		6020H	✓	E229633	WELLS
11	VARNISH		WP-2952F-2G	✓	E72979	HITACHI

REPORT BY	CHECK BY	APPROVED BY	CUSTOMER :	DATE	
			PART NO : 81P-14005	REV NO.	
			ISSUE NO :	PAGE	4 - 4