

1. MECHANICAL & ASSEMBLY :

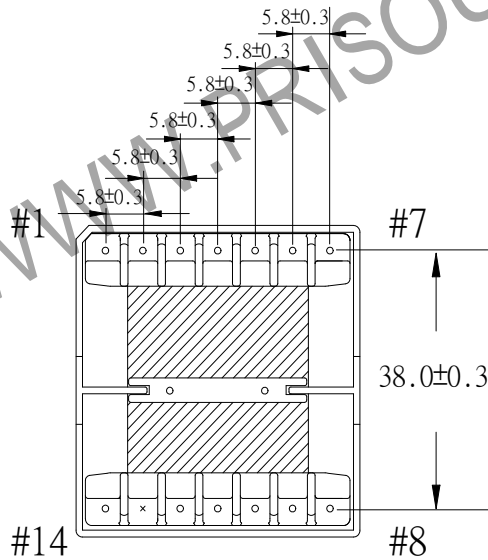
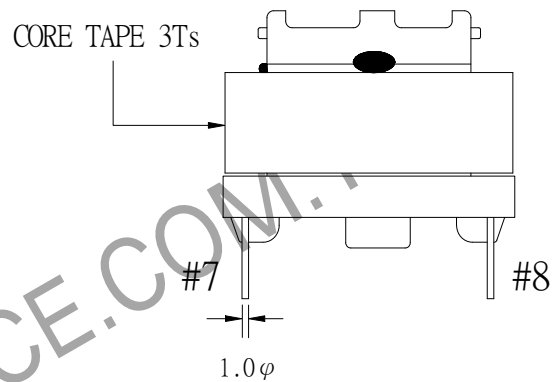
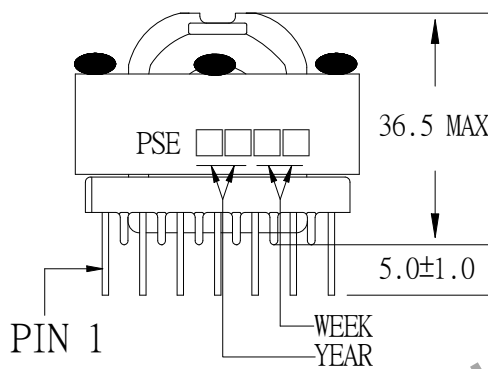
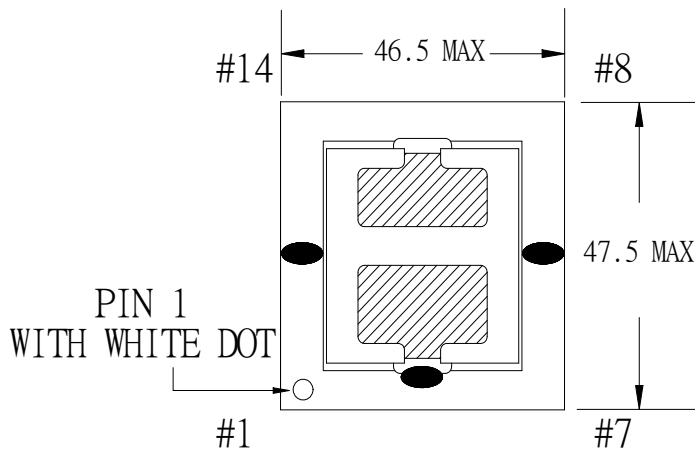

NOTE:

1. EPOXY FIXED BETWEEN CORE & CORE (TTL:2 POINTS)
2. EPOXY FIXED TOP OF CASE & CORE.(ONE POINT AT PIN1-7 SIDE).
3. PIN 13 NO.
4. PIN 1 WITH WHITE DOT

UNIT : m/ m

| | | | | | |
|-----------|----------|-------------|---------------------|---------|-------|
| REPORT BY | CHECK BY | APPROVED BY | CUSTOMER : | DATE | |
| | | | PART NO : 80P-17001 | REV NO. | |
| | | | ISSUE NO : | PAGE | 4 - 4 |

2. WINDING CONFIGURATION :

| STEP | WINDING | MARGIN TAPE | START-FINISH | COPPER WIRE | TURNS | LAYER TAPE | METHOD |
|------|---------|----------------------|--------------|------------------------------|-------|--------------|--------|
| 1 | N1 | | 14 - 12 | 0.1 ϕ /60C | 32 | 1T/1T/1T/2Ts | CLOSE |
| 2 | N2 | ~/5.0mm \times 6Ts | 1,2 - 3,4,5 | 0.12 ϕ /100C \times 4 | 2 | 2Ts | CLOSE |
| 3 | N3 | ~/5.0mm \times 6Ts | 3,4,5 - 6,7 | 0.12 ϕ /100C \times 4 | 2 | 2Ts | CLOSE |
| | | | | | | | |
| | | | | | | | |

NOTE:

3. ELECTRICAL CHARACTERISTICS :

| PIN NO. | INDUCTANCE 100 KHz, 1.0V _{rms} | LEAKAGE INDUCTANCE 100 KHz, 1.0V _{rms} | VOLTAGE RATIO(V) f= 20KHz | DCR MAX. AT 25°C |
|-------------|--|--|-----------------------------------|---------------------|
| 14 - 12 | 398.0 μ H \pm 15% | 134.0 μ H MAX | INPUT 1 V _{rms} | 100.5 m Ω |
| 1,2 - 3,4,5 | | SHORT | 0.0533V _{rms} \pm 5.0% | 2.0 m Ω |
| 3,4,5 - 6,7 | | SHORT | 0.0539V _{rms} \pm 5.0% | 2.0 m Ω |
| | | | | |
| | | | | |

HI-POT TEST : (AT 1 mA, 1 SEC)

| | | | |
|-----|----|------|----------|
| PRI | TO | SEC | 3600 VAC |
| PRI | TO | CORE | 1800 VAC |
| SEC | TO | CORE | 1800 VAC |

INSULATION RESISTANCE: (AT DC 500V)

| | | | |
|-----|----|------|---------------------|
| PRI | TO | SEC | 100 M Ω MIN. |
| PRI | TO | CORE | 100 M Ω MIN. |
| SEC | TO | CORE | 100 M Ω MIN. |

IMPULSE TEST: 1200V_o-P(14-12)

| | | | | | |
|-----------|----------|-------------|---------------------|---------|-------|
| REPORT BY | CHECK BY | APPROVED BY | CUSTOMER : | DATE | |
| | | | PART NO : 80P-17001 | REV NO. | |
| | | | ISSUE NO : | PAGE | 4 - 2 |

4. WINDING SEQUENCE:

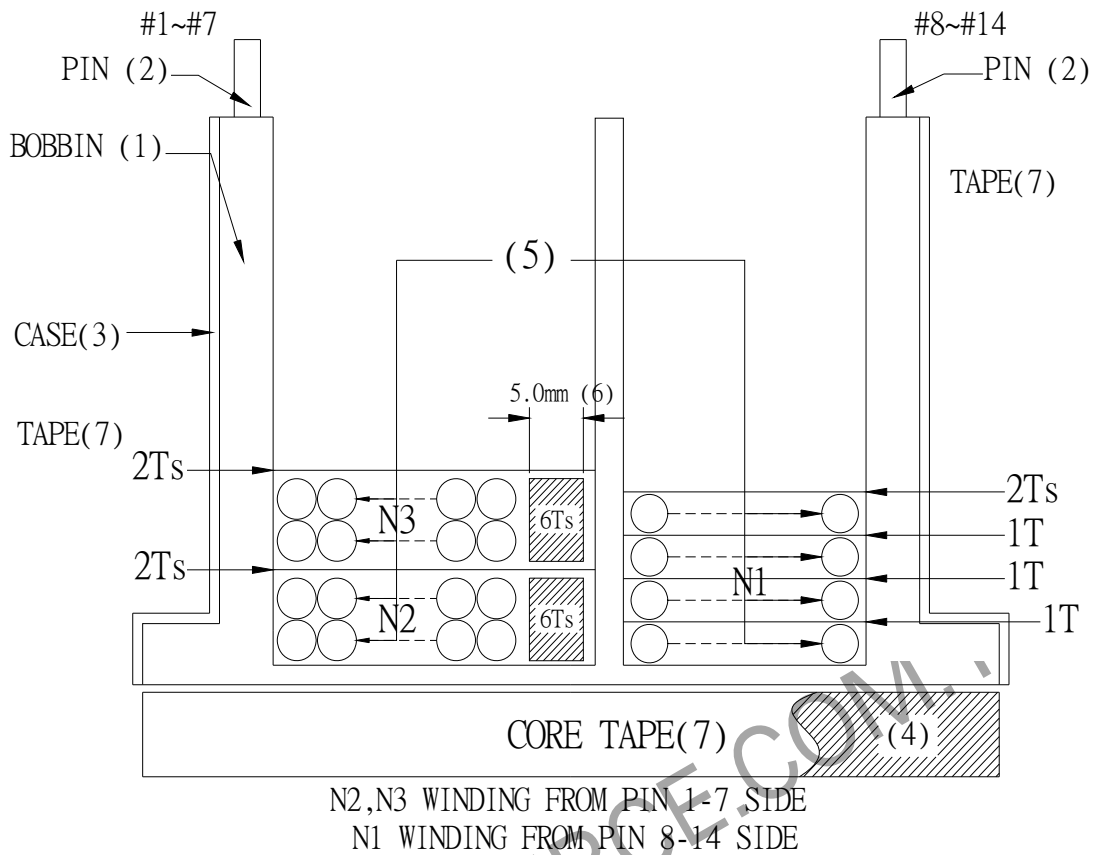

5. SCHEMATIC:

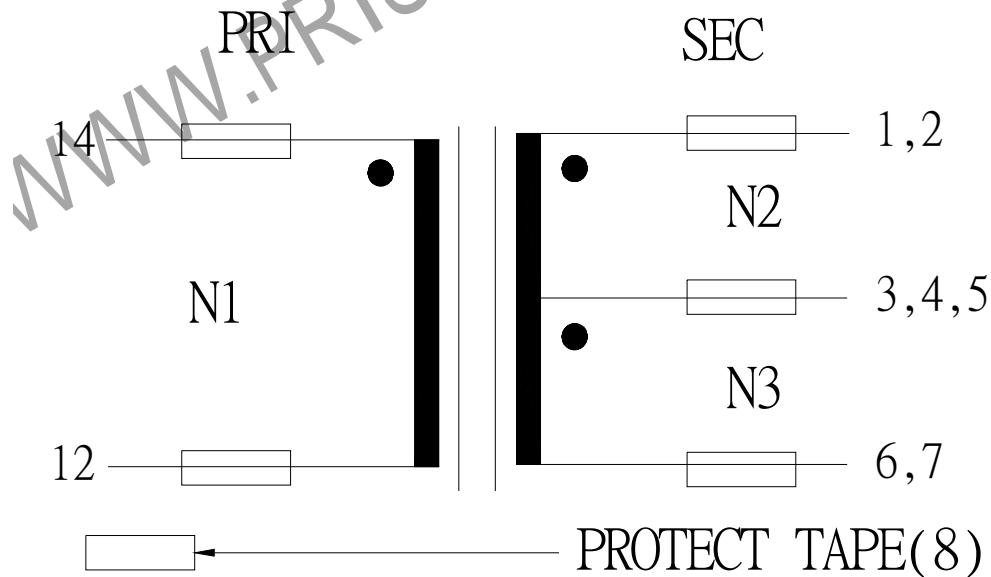

| | | | | |
|-----------|----------|-------------|---------------------|------------|
| REPORT BY | CHECK BY | APPROVED BY | CUSTOMER : | DATE |
| | | | PART NO : 80P-17001 | REV NO. |
| | | | ISSUE NO : | PAGE 4 - 3 |

6 . MATERIALS LIST :

| NO | DESCRIPTION | ITEM | MATERIAL | LIST OF SAMPLE | UL NO. | MANUFACTURE |
|----|--------------|------|---|----------------|---------|-------------|
| 1 | BOBBIN | (1) | PHENOLIC (PM9820) Thickness:0.30mm Min. | √ | E41429 | SUMITOMO |
| 2 | PIN | (2) | TINNED C.P WIRE φ1.0 | √ | | WELL FORE |
| 3 | CASE | (3) | PET FR530 Thickness:0.40mm Min. | √ | E41938 | E I DUPONT |
| 4 | CORE | (4) | FERRITE CORE ETD44/45/15 TP4 | √ | | TDG |
| 5 | COPPER WIRE | (5) | POLYURETHANE (1UEW/2UEW) TYPY-130 MW75-C | √ | E197768 | HENG YA |
| 6 | MARGIN TAPE | (6) | COMPOSITE FILM #44T-A | √ | E17385 | 3M |
| 7 | MYLAR TAPE | (7) | POLYESTER FILM #1318Y-1 | √ | E17385 | 3M |
| 8 | PROTECT TAPE | (8) | COMPOSITE FILM #44-2L | √ | E17385 | 3M |
| 9 | EPOXY | | 6020H | √ | E229633 | WELLS |
| 10 | VARNISH | | TVB2180T | √ | E83702 | KYOCERA |

| | | | | | |
|-----------|----------|-------------|---------------------|---------|-------|
| REPORT BY | CHECK BY | APPROVED BY | CUSTOMER : | DATE | |
| | | | PART NO : 80P-17001 | REV NO. | |
| | | | ISSUE NO : | PAGE | 4 - 4 |