

1. MECHANICAL & ASSEMBLY :

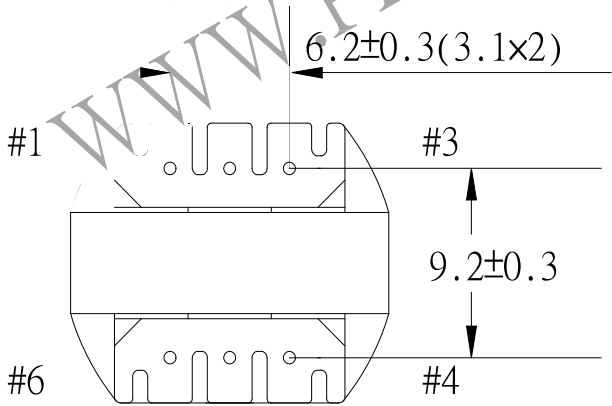
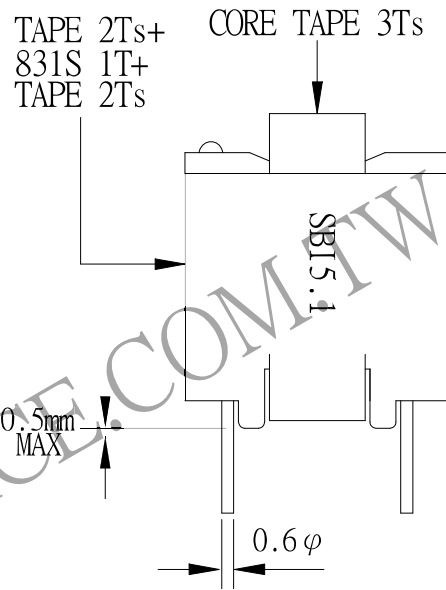
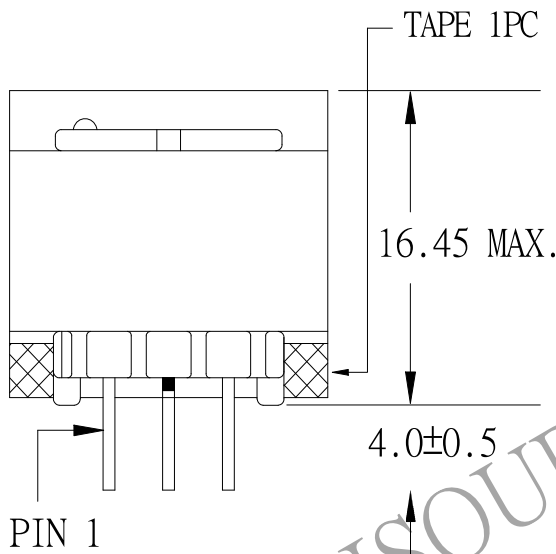
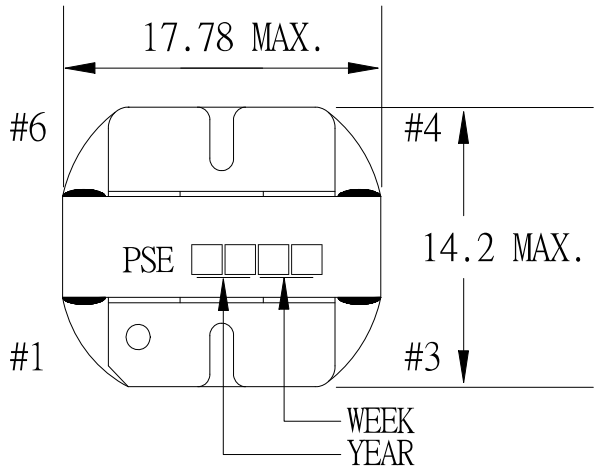

NOTE:

1. PIN 2 & PIN 4 CUT SHORTER AFTER SOLDERING
2. MEET CLASS F INSULATION SYSTEM "SBI5.1" UL E181448
3. EPOXY FIXED BETWEEN CORE & CORE(TTL:4 POINTS)
4. SOLDERPOINT CAN BE OVER STAND OFF 0.5 mm MAX
5. ADD ONE DROPS OF GLUE INSIDE OF THE CORE TOP.

UNIT : m/m

REPORT BY	CHECK BY	APPROVED BY	CUSTOMER :	DATE	
			PART NO : 63P-17002	REV NO.	
			ISSUE NO :	PAGE	4 - 1

2. WINDING CONFIGURATION:

STEP	WINDING	MARGIN TAPE	START-FINISH	COPPER WIRE	TURNS	LAYER TAPE	TUBE	METHOD
1	SHIELD 1		1 - NC	0.17φ	37	1T		SPACE
2	P1(1/2)		3 - 2	0.17φ	37	1T		SPACE
3	P2(1/2)		6 - 4	0.37φ	19	1T		CLOSE
4	P2(2/2)		4 - 5	0.37φ	19	1T		CLOSE
5	P1(2/2)		2 - 1	0.17φ	37	2Ts		CLOSE
6								
7	SHIELD 2		NC - 5	COPPER FOIL	1	2Ts		AROUND BOBBIN & CORE

NOTE:

3. ELECTRICAL CHARACTERISTICS:

PIN NO.	INDUCTANCE 1.0 KHz, 1.0Vrms	LEAKAGE INDUCTANCE 100KHz, 1.0Vrms	VOLTAGE RATIO(V) F= 20KHz INPUT 1 Vrms	DCR MAX. AT 25°C
3 - 1	438.1uH ±7.0%	8.0 uH Max.		2.5Ω
6 - 5		SHORT	0.5124 Vrms±3.0%	250mΩ
4 - 5			0.2576 Vrms±4.0%	124.5mΩ
2 - 1			0.5114 Vrms±3.0%	1.5Ω
6 - 4			0.2576 Vrms±4.0%	110.5mΩ
3 - 2			0.4883 Vrms±4.0%	0.9Ω

HI-POT TEST :(AT 10 mA, 2 Sec.)

P1. TO P2. 2400 VAC
P1. TO CORE. 2400 VAC
P2. TO CORE. 2400 VAC

INSULATION RESISTANCE:(AT DC 500V)

P1. TO P2. 100 MΩ MIN.
P1. TO CORE. 100 MΩ MIN.
P2. TO CORE. 100 MΩ MIN.

REPORT BY	CHECK BY	APPROVED BY	CUSTOMER :	DATE
			PART NO : 63P-17002	REV NO.
			ISSUE NO :	PAGE 4 - 2

4. WINDING SEQUENCE:

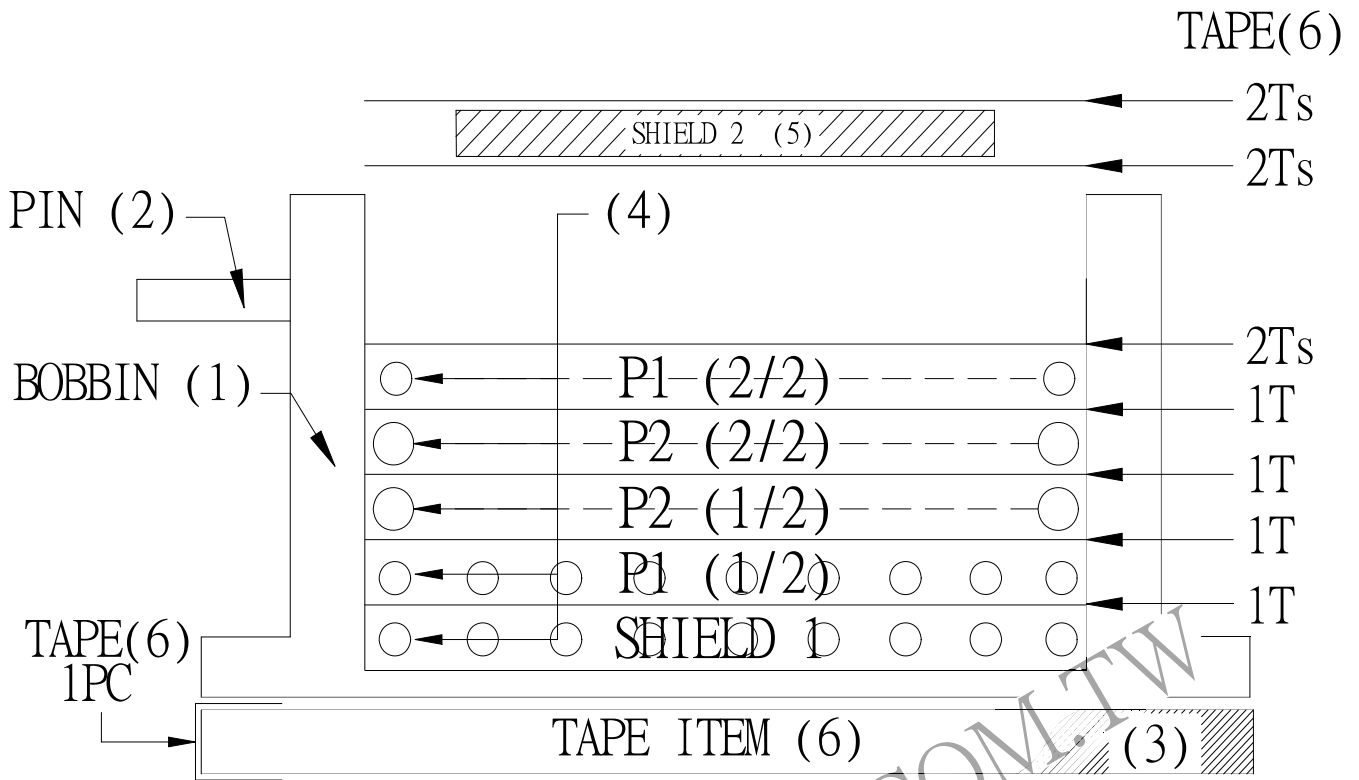

5. SCHEMATIC:

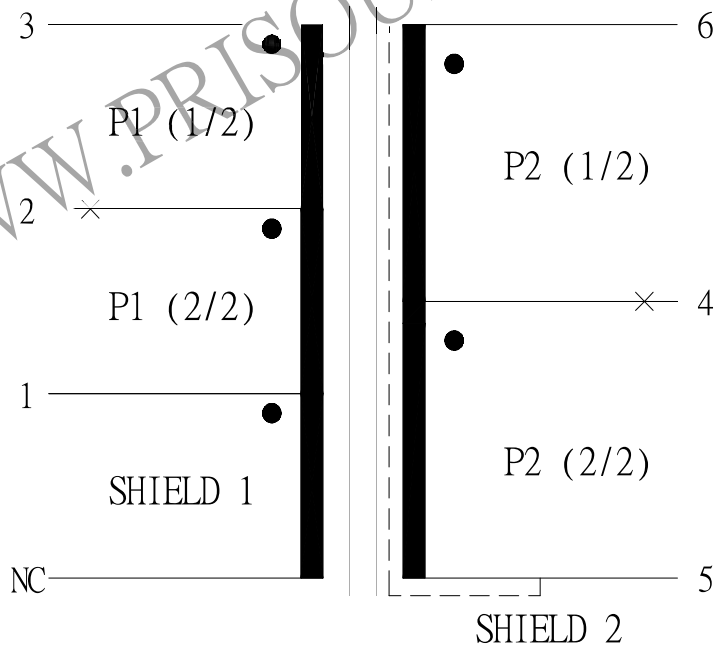

REPORT BY	CHECK BY	APPROVED BY	CUSTOMER :	DATE	
			PART NO : 63P-17002	REV NO.	
			ISSUE NO :	PAGE	4 - 3