

1. MECHANICAL & ASSEMBLY :

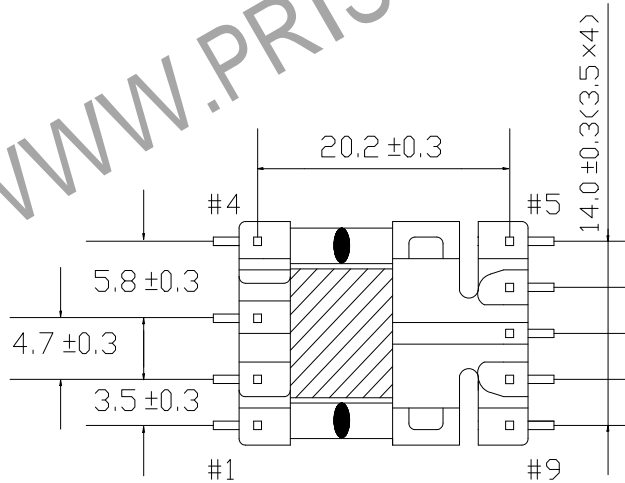
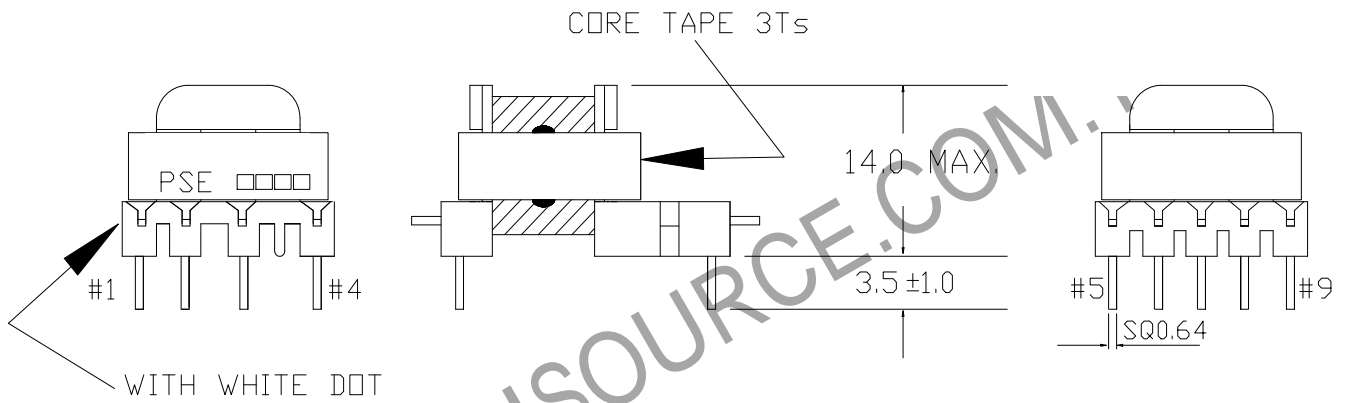
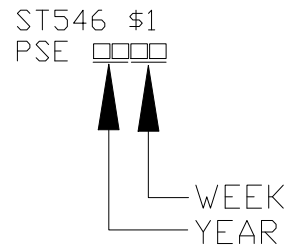
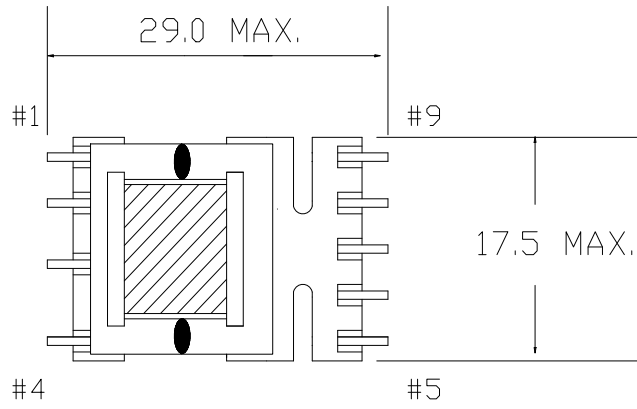

NOTE:

1. EPOXY FIXED BETWEEN CORE & CORE (TTL:4 POINTS). EPOXY FIXED OF BOBBIN & CORE.(ONE POINT AT PIN1-4 SIDE).
2. PIN 1 WITH WHITE DOT

NIT:mm

REPORT BY	CHECK BY	APPROVED BY	CUSTOMER :	DATE	
			PART NO : 54P-17057	REV NO.	
			ISSUE NO :	PAGE	4 - 1

2. WINDING CONFIGURATION :

STEP	WINDING	MARGIN TAPE	START-FINISH	COPPER WIRE	TURNS	LAYER TAPE	TUBE	METHOD
1						1T		
2	P3	3.5mm/1.0mm×1T	5 - 9	0.16φ	2	3Ts		SPACE
3	P1	3.5mm/1.0mm×3Ts	6 - 7	0.16φ	20	4Ts	#28	BIFILAR, CLOSE
4	P2		7 - 8	0.16φ	20			
5	S1	1.0mm/3.5mm×1T	4 - 3	0.16φ	11	2Ts		CLOSE
6	S2	1.0mm/3.5mm×1T	2 - 1	0.16φ	11	2Ts		CLOSE

NOTE:

3. ELECTRICAL CHARACTERISTICS :

PIN NO.	INDUCTANCE 1.0 KHz, 1.0Vrms	LEAKAGE INDUCTANCE KHz, Vrms	VOLTAGE RATIO(V) F= 20KHz	DCR MAX. AT 25°C
6 - 8	400.0uH±15%		INPUT 1Vrms	
5 - 9			0.0493Vrms±7.0%	88.5 mΩ
4 - 3			0.2678Vrms±4.0%	0.45 Ω
2 - 1			0.2678Vrms±4.0%	0.45 Ω
6 - 7			0.5000Vrms±3.0%	0.65 Ω
7 - 8			0.5000Vrms±3.0%	0.65 Ω

HI-POT TEST : (AT 1 mA , 1 SEC.)

PRI. TO SEC. 3600 VAC

PRI,SEC TO CORE. 1800 VAC

INSULATION RESISTANCE:

PRI. TO SEC. 100 MΩ ≧ . (AT DC 1000V)

PRI,SEC TO CORE. 100 MΩ ≧ . (AT DC 500V)

REPORT BY	CHECK BY	APPROVED BY	CUSTOMER :	DATE
			PART NO : 54P-17057	REV NO.
			ISSUE NO :	PAGE 4 - 2

4. WINDING SEQUENCE:

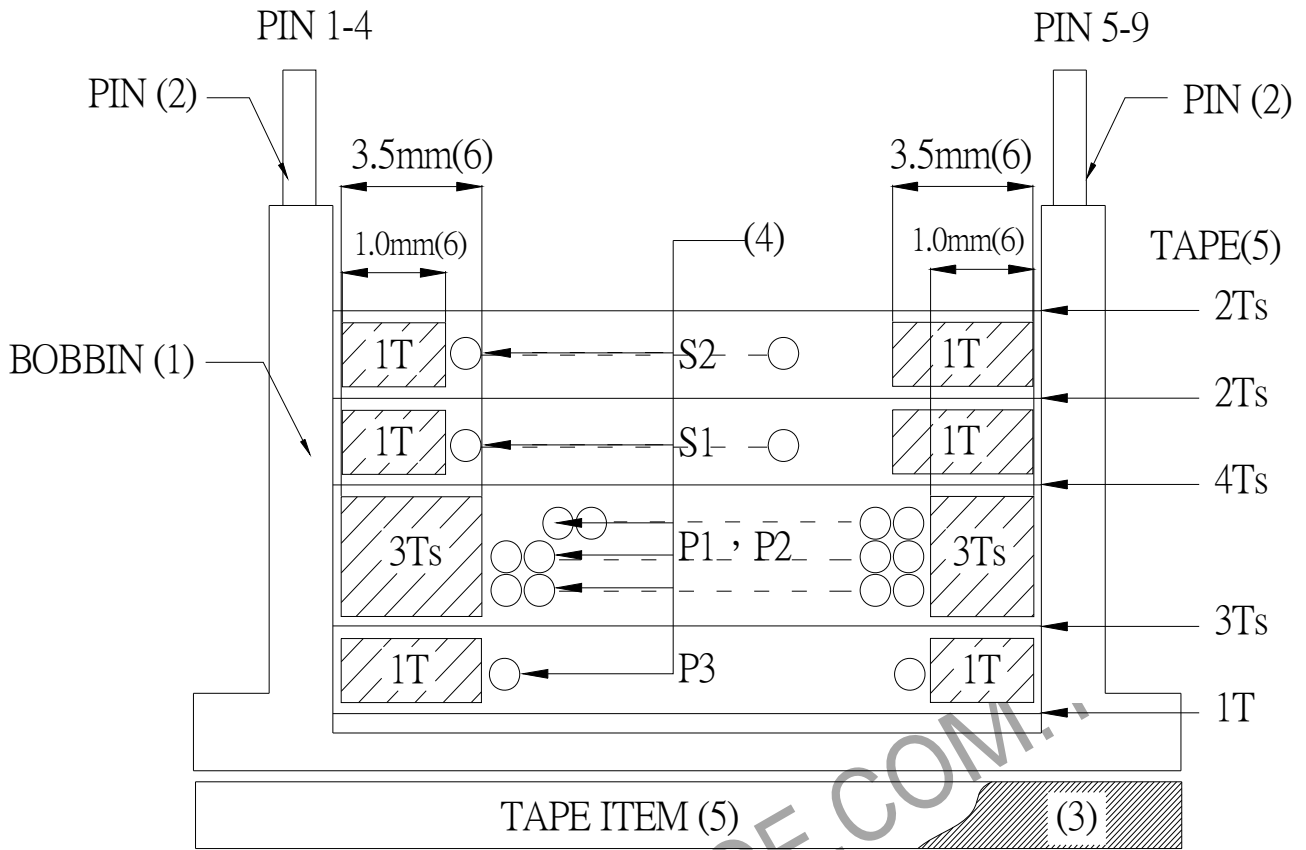

S1, S2 WINDING FROM PIN 1-4 SIDE
 P3, P1, P2 WINDING FROM PIN 5-9 SIDE

5. SCHEMATIC:

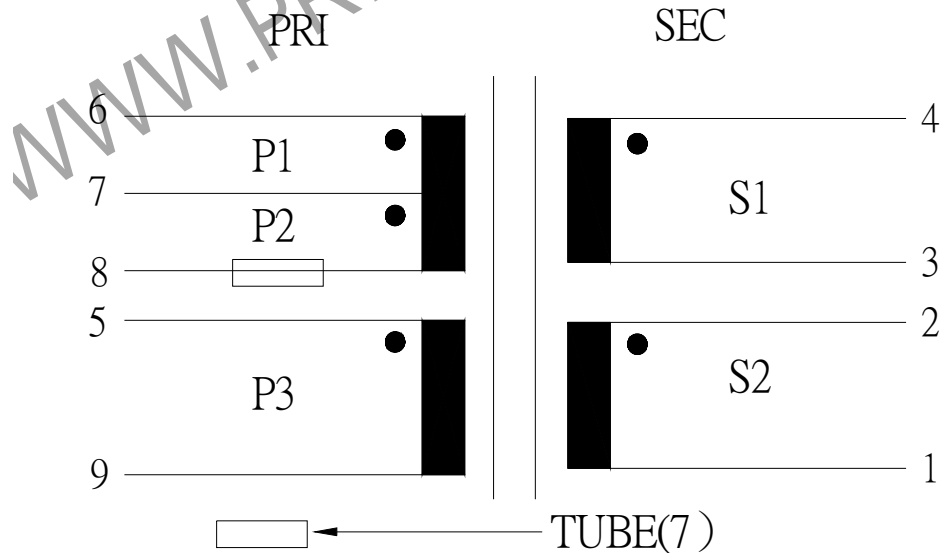

REPORT	BY	CHECK	APPROVED BY	CUSTOMER :	DATE	
				PART NO : 54P-17057	REV NO.	
				ISSUE NO :	PAGE	4 - 3

6. MATERIAL LIST :

NO.	DESCRIPTION	ITEM	MATERIAL	LIST OF SAMPLE	UL NO.	MANUFACTURER
1	BOBBIN	(1)	PHENOLIC (PM9820) Thickness:0.30mm Min. FX-1651	✓	E41429	SUMITOMO FuXiang
2	PIN	(2)	TINNED C.P WIRE □0.64	✓		WELL FORE
3	CORE	(3)	FERRITE CORE EE16A TP4	✓		TDG
4	COPPER WIRE	(4)	POLYURETHANE(1UEW) TYPU-130 MW75-C	✓	E197768	HENG YA
5	MYLAR TAPE	(5)	POLYESTER FILM #1318Y-1	✓	E17385	3M
6	MARGIN TAPE	(6)	COMPOSITE FILM #44D-A	✓	E17385	3M
7	TUBE	(7)	TEFLON TUBE TFL	✓	E156256	GREAT HOLDING
8	EPOXY		6020H	✓	E229633	WELLS
9	VARNISH		TVB2180T	✓	E83702	KYOCERA

REPORT BY	CHECK BY	APPROVED BY	CUSTOMER :	DATE	
			PART NO : 54P-17057	REV NO.	
			ISSUE NO :	PAGE	4 - 4