

1. MECHANICAL & ASSEMBLY :

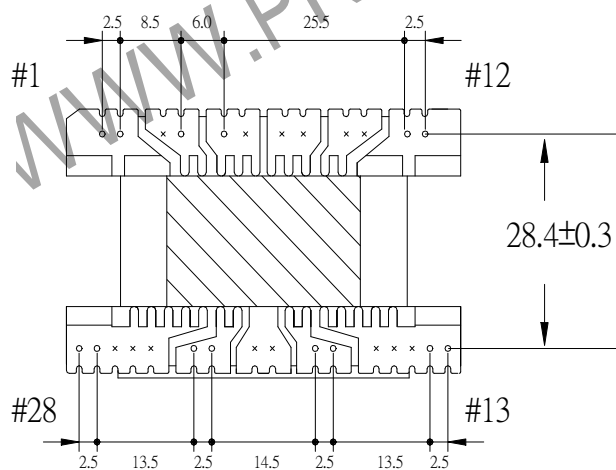
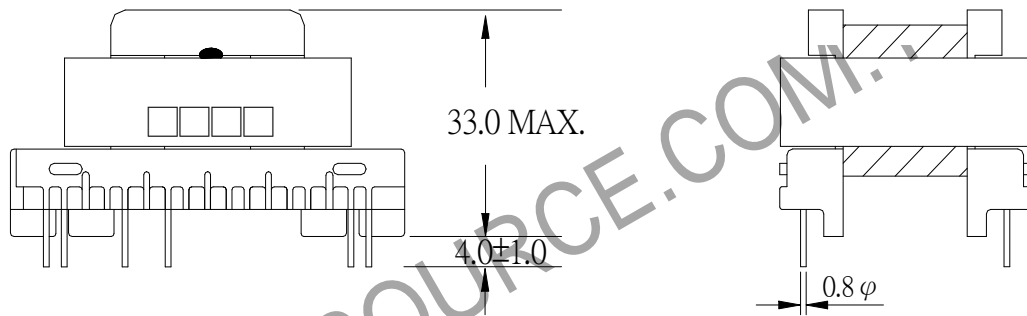
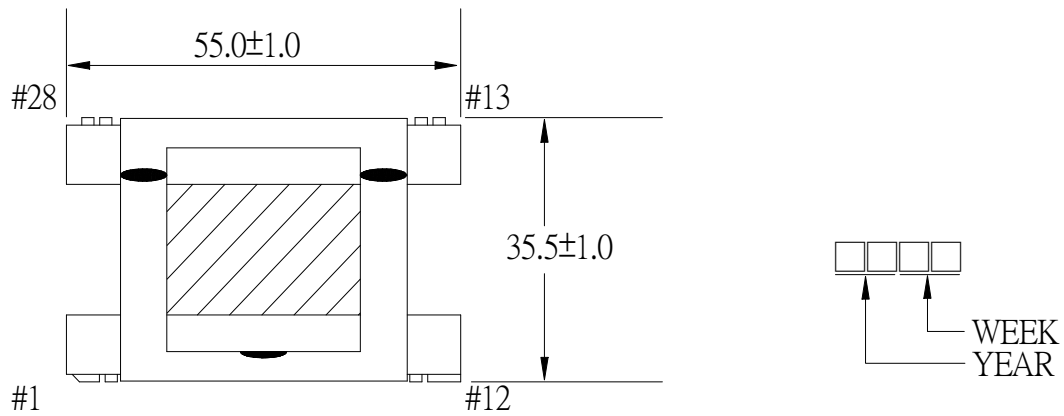

NOTE:

1. PIN 3.6.7.8.9.10.15.16.17
20. 21. 24. 25. 26 NO
2. EPOXY FIXED BETWEEN CORE & CORE (TTL: 2 POINTS), EPOXY FIXED TOP OF BOBBIN & CORE (ONE POINT AT PIN 1-12 SIDE)

UNIT : m/m

REPORT BY	CHECK BY	APPROVED BY	CUSTOMER :	DATE
			PART NO : 54P-16089	REV NO.
			ISSUE NO :	PAGE
				4 - 1

2. WINDING CONFIGURATION:

STEP	WINDING	MARGIN TAPE	START-FINIS	COPPER WIRE	TURNS	TUBE	LAYER TAPE	METHOD
1	N2 1/2	2.5mm/2.5m×2Ts	5 - 4	0.40φ	12Ts	φ0.6	4Ts	SPACE
2	N3	2.5mm/2.5m×2Ts	11 - 12	0.23φ	10Ts	φ0.6	4Ts	SPACE
3	N4	2.5mm/2.5m×2Ts	13 - 14	0.29φ	21Ts	φ0.6	4Ts	SPACE
4	N5	2.5mm/2.5m×1T	18 - 19	0.15φ	21Ts	φ0.6	4Ts	SPACE
5	N6	2.5mm/2.5m×1T	22 - 23	0.15φ	21Ts	φ0.6	4Ts	SPACE
6	N7	2.5mm/2.5m×2Ts	27 - 28	0.29φ	21Ts	φ0.6	4Ts	SPACE
7	N1	2.5mm/2.5m×1T	1 - 2	0.15φ	26Ts	φ0.6	4Ts	SPACE
8	N2 2/2	2.5mm/2.5m×2Ts	5 - 4	0.40φ	12Ts	φ0.6	4Ts	SPACE

NOTE:

3. ELECTRICAL CHARACTERISTICS:

PIN NO.	INDUCTANCE 10 KHz, 1.0Vrms	DC SATURATION KHz, Vrms+DC A	VOLTAGE RATIO(V) f= 20 KHz	DCR MAX. AT 25°C
5 - 4	78.45 uH ± 25 %		INPUT 1Vrms	56.7mΩ ~ 69.3mΩ
11 - 12			0.8310 Vrms±3.0%	256.7mΩ ~ 313.8mΩ
13 - 14			1.7503 Vrms±3.0%	338.9mΩ ~ 414.2mΩ
18 - 19			1.7495 Vrms±3.0%	1.26Ω ~ 1.54Ω
22 - 23			1.7441 Vrms±3.0%	1.35Ω ~ 1.65Ω
27 - 28			1.7459 Vrms±3.0%	378.9mΩ ~ 463.1mΩ
1 - 2			2.1602 Vrms±3.0%	1.98Ω ~ 2.42Ω

HI-POT TEST :(AT 0.5 mA , 2SEC.)

WINDING. TO WINDING. 3000 VAC

INSULATION RESISTANCE:(AT DC 1500V)

WINDING. TO WINDING. 100 MΩ MIN.

REPORT BY	CHECK BY	APPROVED BY	CUSTOMER :	DATE
			PART NO : 54P-16089	REV NO.
			ISSUE NO :	PAGE 4 - 2

4. WINDING SEQUENCE :

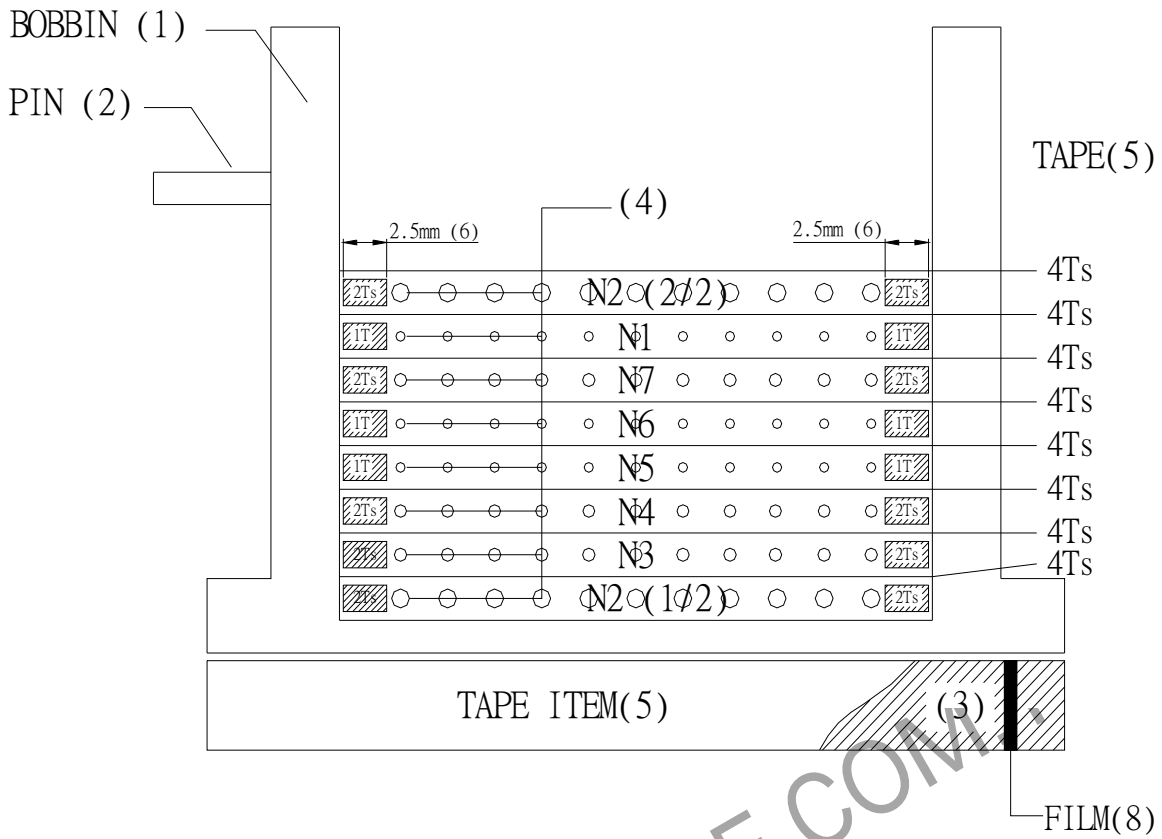

5. SCHEMATIC :

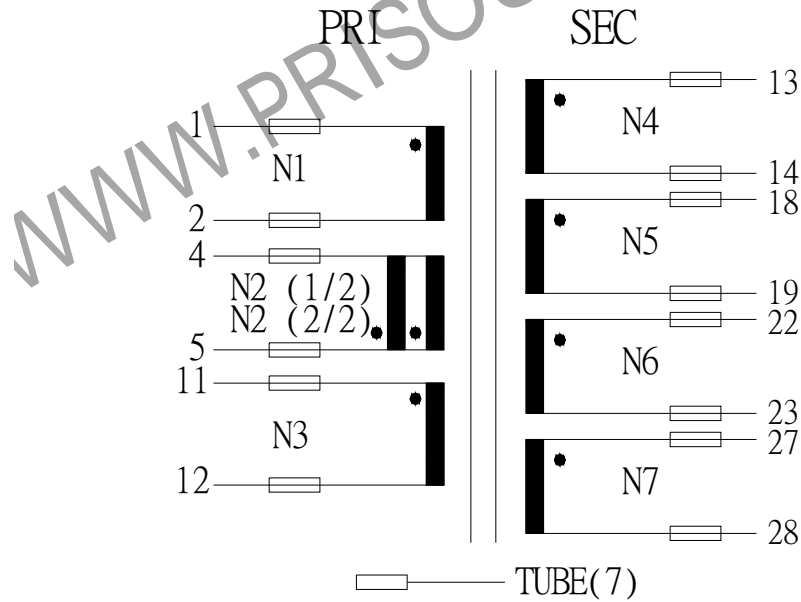

REPORT BY	CHECK BY	APPROVED BY	CUSTOMER :	DATE
			PART NO : 54P-16089	REV NO.
			ISSUE NO :	PAGE
				4 - 3

6. MATERIALS LIST :

NO	DESCRIPTION	ITEM	MATERIAL	LIST OF SAMPLE	UL NO.	MANUFACTURE
1	BOBBIN	(1)	PHENOLIC (T375J) Thickness:0.8mm Min.	√	E59481	CHANG CHUN
2	PIN	(2)	TINNED C.P WIRE φ0.8	√		WELL FORE
3	CORE	(3)	FERRITE CORE EI-40 TP4	√		TDG
4	COPPER WIRE	(4)	POLYURETHANE (2UEW) TYPYU-130 NW75-C	√	E197768	HENG YA
5	MYLAR TAPE	(5)	POLYESTER FILM #1318-1	√	E17385	3M
6	MARGIN TAPE	(6)	COMPOSITE FILM #44D-A	√	E17385	3M
7	TUBE	(7)	RSU-1(RS0.3x0.6mm)	√	E67922	NISSEI
8	FILM	(8)	Lumirror t0.188×11×39mm	√	E86511	TORAY
9	EPOXY		EP-138	√		CEMEDINE
10	VARNISH		TVB2180T	√	E83702	KYOCERA

REPORT BY	CHECK BY	APPROVED BY	CUSTOMER :	DATE	
			PART NO : 54P-16089	REV NO.	
			ISSUE NO :	PAGE	4 - 4