

1. MECHANICAL & ASSEMBLY :

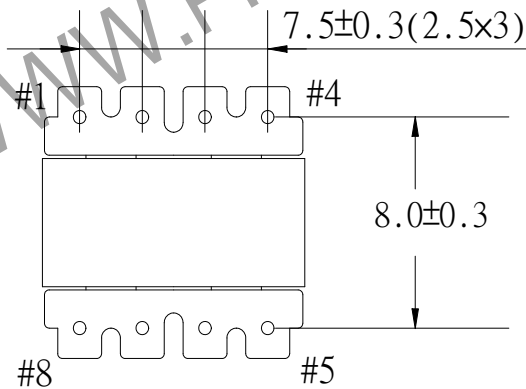
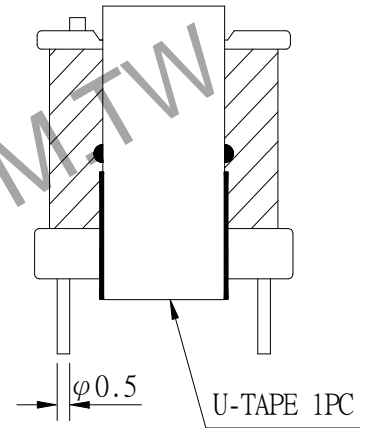
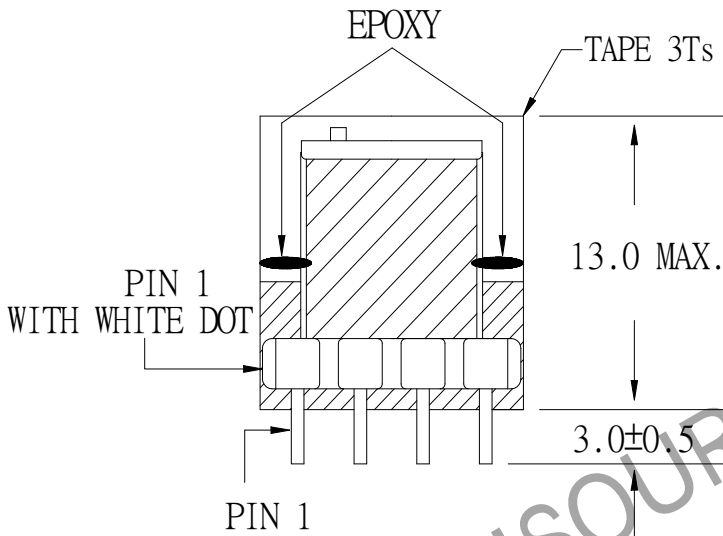
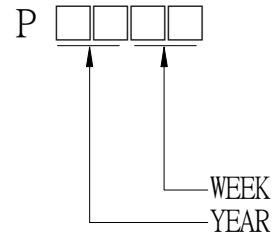
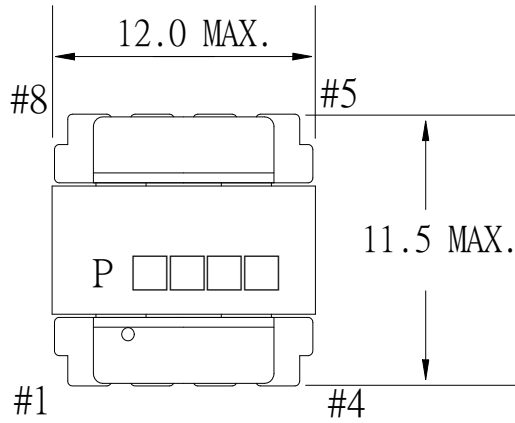

NOTE:

1. EPOXY FIXED BETWEEN CORE & CORE (TTL:4 POINTS). EPOXY FIXED TOP OF BOBBIN & CORE.(ONE POINT).
2. PIN 1 WITH WHITE DOT
3. ADHESIVE EP-138 FIXED BETWEEN CORE & CORE (TTL:2 POINTS)

UNIT:m/m

| | | | | | |
|-----------|----------|-------------|---------------------|---------|-------|
| REPORT BY | CHECK BY | APPROVED BY | CUSTOMER : | DATE | |
| | | | PART NO : 54P-16046 | REV NO. | |
| | | | ISSUE NO : | PAGE | 4 - 1 |

2. WINDING CONFIGURATION :

| STEP | WINDING | MARGIN TAPE | START-FINISH | COPPER WIRE | URNS | LAYER TAPE | METHOD |
|------|---------|-------------|--------------|-------------|------|------------|--------|
| 1 | P1 | | 1 - 4 | TEX-E 0.30φ | 14 | 1T | CLOSE |
| 2 | S1 | | 8 - 5 | 0.30φ | 24 | 2Ts | CLOSE |
| | | | | | | | |
| | | | | | | | |
| | | | | | | | |
| | | | | | | | |
| | | | | | | | |

NOTE:

3. ELECTRICAL CHARACTERISTICS :

| PIN NO. | INDUCTANCE 1.0 KHz, 1.0Vrms | LEAKAGE INDUCTANCE KHz, Vrms | VOLTAGE RATIO(V) F= 20KHz | DCR MAX. AT 25°C |
|---------|--------------------------------|---------------------------------|------------------------------|---------------------|
| 1 - 4 | 150.0uH MIN | | 0.5819Vrms±3.0% | 91.0 mΩ |
| 8 - 5 | 400.0uH MIN | | INPUT 1Vrms | 188.0mΩ |
| | | | | |
| | | | | |
| | | | | |

HI-POT TEST :(AT 1 mA , 2SEC.)

PRI TO SEC 2500 VAC

PRI ,SEC TO CORE 1800 VAC

INSULATION RESISTANCE:(AT DC 500V)

PRI TO SEC 100 MΩ MIN.

PRI ,SEC TO CORE 100 MΩ MIN.

| | | | | | |
|-----------|----------|-------------|---------------------|---------|-------|
| REPORT BY | CHECK BY | APPROVED BY | CUSTOMER : | DATE | |
| | | | PART NO : 54P-16046 | REV NO. | |
| | | | ISSUE NO : | PAGE | 4 - 2 |

4. WINDING SEQUENCE:

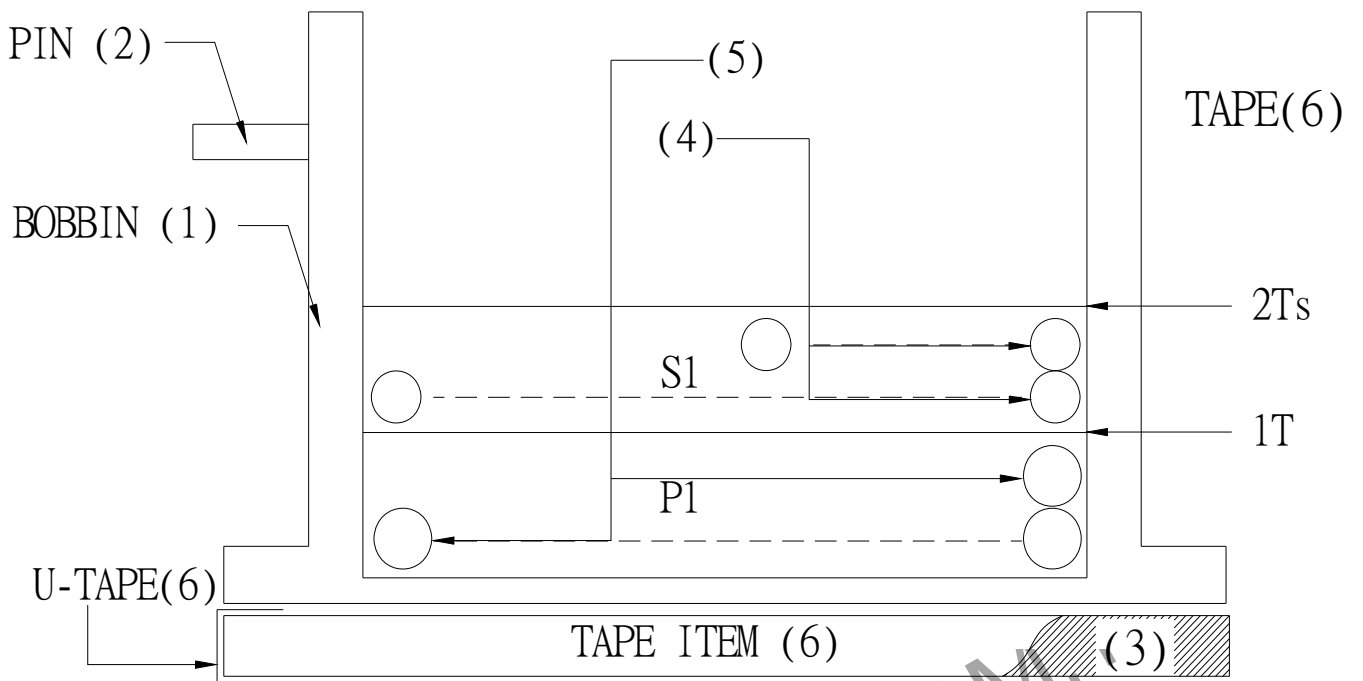

5. SCHEMATIC:

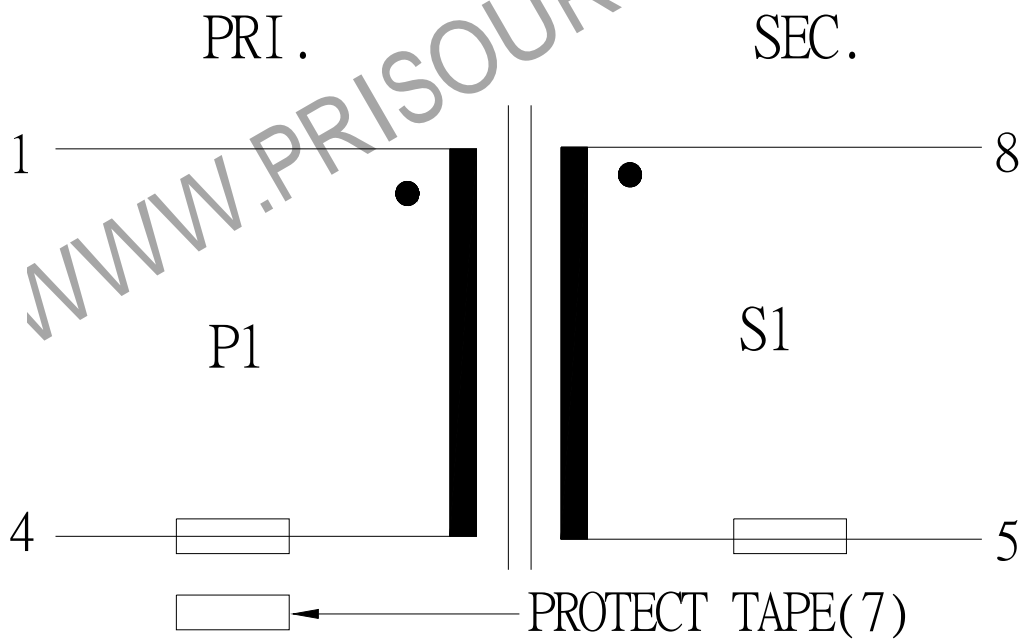

| | | | | | |
|-----------|----------|-------------|---------------------|---------|-------|
| REPORT BY | CHECK BY | APPROVED BY | CUSTOMER : | DATE | |
| | | | PART NO : 54P-16046 | REV NO. | |
| | | | ISSUE NO : | PAGE | 4 - 3 |

6. MATERIAL LIST :

| NO. | DESCRIPTION | ITEM | MATERIAL | LIST OF SAMPLE | UL NO. | MANUFACTURER |
|-----|--------------|------|--|----------------|---------|--------------|
| 1 | BOBBIN | (1) | PHENOLIC (PM9820) Thickness:0.30mm Min. | ✓ | E41429 | SUMITOMO |
| 2 | PIN | (2) | TINNED COPPER WIRE φ0.5 | ✓ | | WELL FORE |
| 3 | CORE | (3) | FERRITE CORE EE10 TP4 | ✓ | | TDG |
| 4 | COPPER WIRE | (4) | POLYURETHANE(2UEW) MW75-C TYPU-130 | ✓ | E197768 | HENG YA |
| 5 | TRIPLE WIRE | (5) | TEX-E | ✓ | E206440 | FURUKAWA |
| 6 | MYLAR TAPE | (6) | POLYESTER FILM #1318-1(Y) | ✓ | E17385 | 3M |
| 7 | PROTECT TAPE | (7) | COMPOSITE FILM #44-A | ✓ | E17385 | 3M |
| 8 | EPOXY | | 6020H | ✓ | E229633 | WELLS |
| 9 | VARNISH | | TVB2180T | ✓ | E83702 | KYOCERA |

| | | | | | |
|-----------|----------|-------------|---------------------|---------|-------|
| REPORT BY | CHECK BY | APPROVED BY | CUSTOMER : | DATE | |
| | | | PART NO : 54P-16046 | REV NO. | |
| | | | ISSUE NO : | PAGE | 4 - 4 |