

1. MECHANICAL & ASSEMBLY :

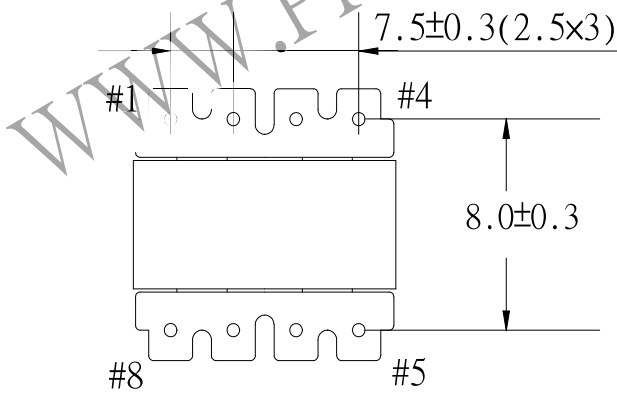
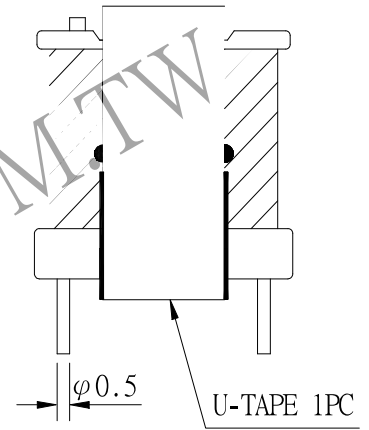
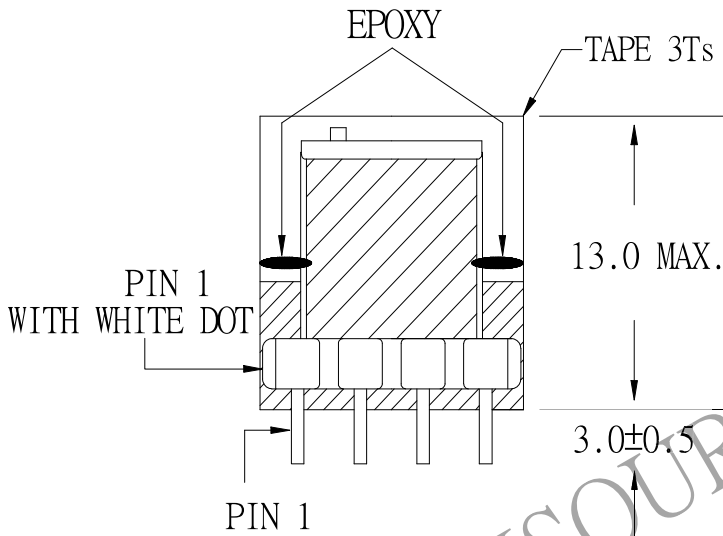
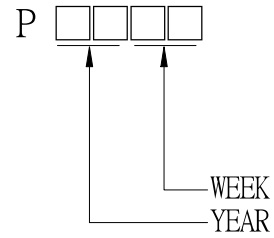
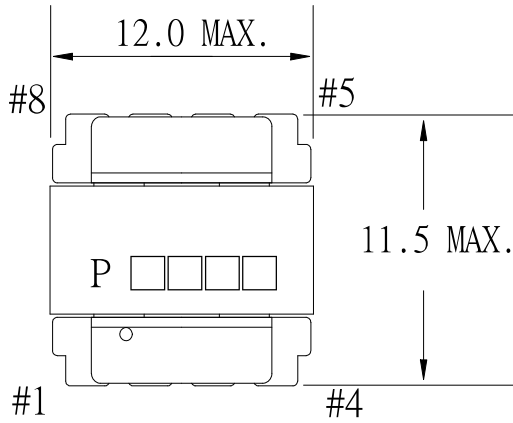

NOTE:

1. EPOXY FIXED BETWEEN CORE & CORE (TTL:4 POINTS). EPOXY FIXED TOP OF BOBBIN & CORE.(ONE POINT).
2. PIN 1 WITH WHITE DOT
3. ADHESIVE EP-138 FIXED BETWEEN CORE & CORE (TTL:2 POINTS)

UNIT:m/m

| | | | | |
|-----------|----------|-------------|---------------------|---------|
| REPORT BY | CHECK BY | APPROVED BY | CUSTOMER : | DATE |
| | | | PART NO : 54P-16046 | REV NO. |
| | | | ISSUE NO : | PAGE |
| | | | | 4 - 1 |

2. WINDING CONFIGURATION:

| STEP | WINDING | MARGIN TAPE | START-FINISH | COPPER WIRE | URNS | LAYER TAPE | METHOD |
|------|---------|-------------|--------------|-------------|------|------------|--------|
| 1 | P1 | | 1 - 4 | TEX-E 0.30φ | 14 | 1T | CLOSE |
| 2 | S1 | | 8 - 5 | 0.30φ | 24 | 2Ts | CLOSE |
| | | | | | | | |
| | | | | | | | |
| | | | | | | | |
| | | | | | | | |
| | | | | | | | |

NOTE:

3. ELECTRICAL CHARACTERISTICS:

| PIN NO. | INDUCTANCE 1.0 KHz, 1.0Vrms | LEAKAGE INDUCTANCE KHz, Vrms | VOLTAGE RATIO(V) F= 20KHz | DCR MAX. AT 25°C |
|---------|--------------------------------|---------------------------------|------------------------------|---------------------|
| 1 - 4 | 150.0uH MIN | | 0.5819Vrms±3.0% | 91.0 mΩ |
| 8 - 5 | 400.0uH MIN | | INPUT 1Vrms | 188.0mΩ |
| | | | | |
| | | | | |
| | | | | |

HI-POT TEST :(AT 1 mA , 2SEC.)

PRI TO SEC 2500 VAC

PRI,SEC TO CORE 1800 VAC

INSULATION RESISTANCE:(AT DC 500V)

PRI TO SEC 100 MΩ MIN.

PRI,SEC TO CORE 100 MΩ MIN.

| | | | | | |
|-----------|----------|-------------|---------------------|---------|-------|
| REPORT BY | CHECK BY | APPROVED BY | CUSTOMER : | DATE | |
| | | | PART NO : 54P-16046 | REV NO. | |
| | | | ISSUE NO : | PAGE | 4 - 2 |

4. WINDING SEQUENCE:

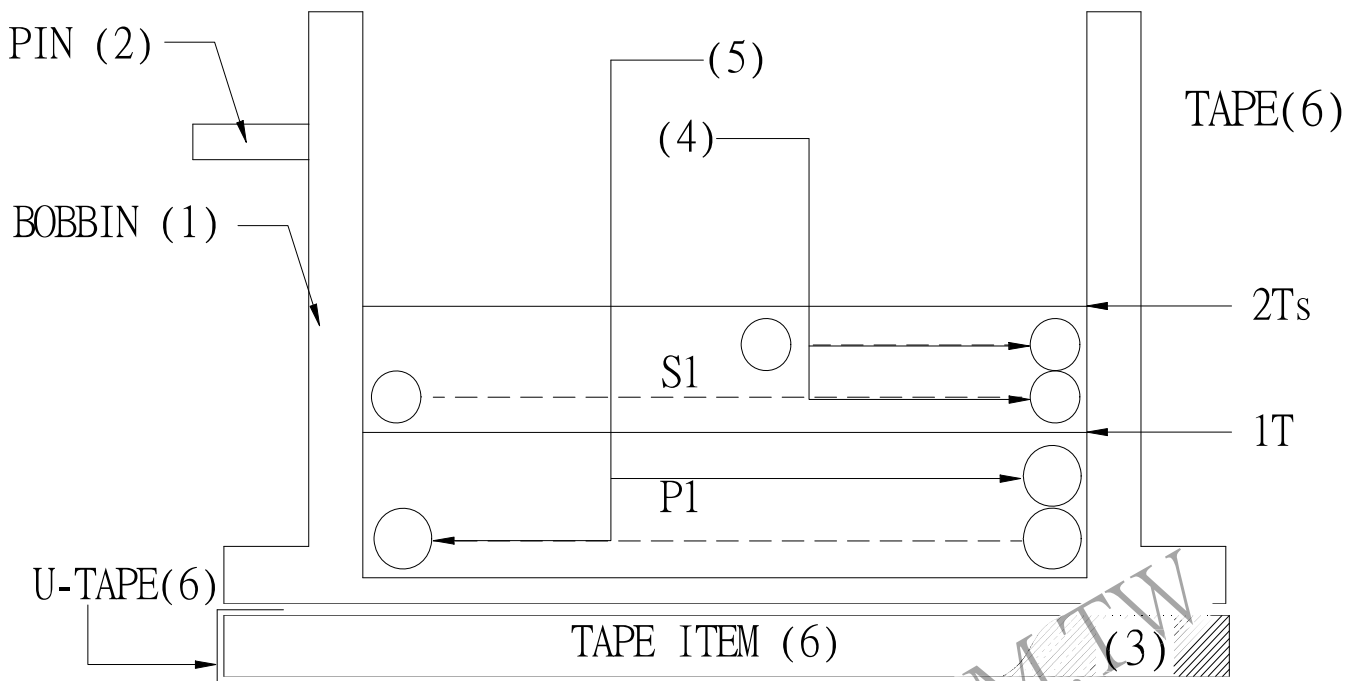

5. SCHEMATIC:

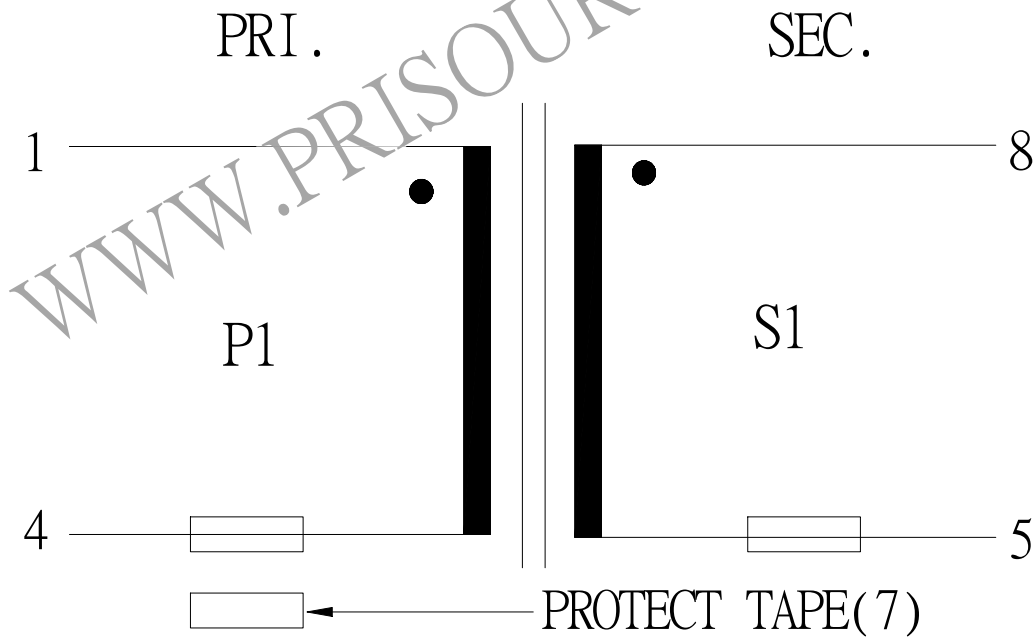

| | | | | | |
|-----------|----------|-------------|---------------------|---------|-------|
| REPORT BY | CHECK BY | APPROVED BY | CUSTOMER : | DATE | |
| | | | PART NO : 54P-16046 | REV NO. | |
| | | | ISSUE NO : | PAGE | 4 - 3 |