

1. MECHANICAL & ASSEMBLY :

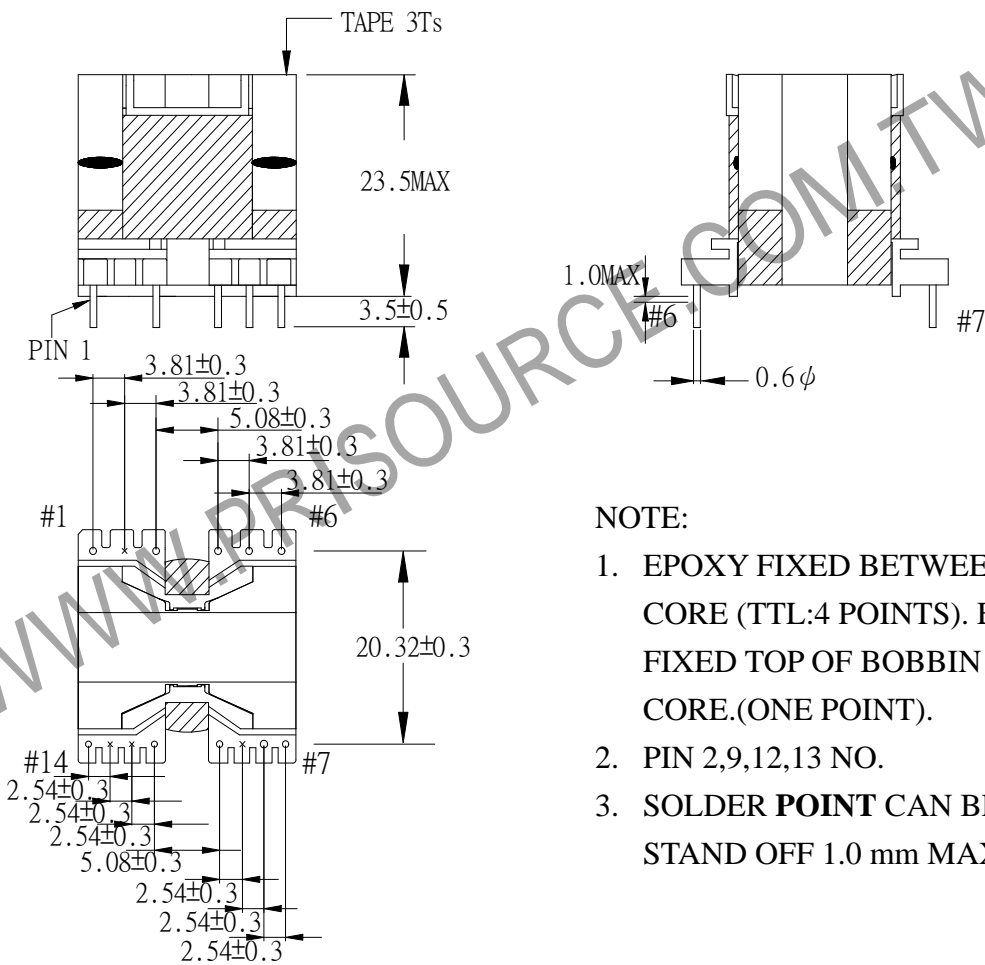
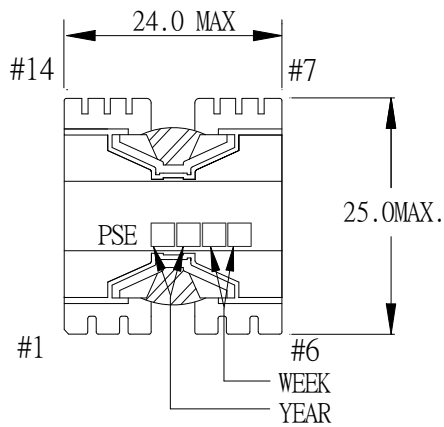

NOTE:

1. EPOXY FIXED BETWEEN CORE & CORE (TTL:4 POINTS). EPOXY FIXED TOP OF BOBBIN & CORE.(ONE POINT).
2. PIN 2,9,12,13 NO.
3. SOLDER POINT CAN BE OVER STAND OFF 1.0 mm MAX

UNIT : mm

REPORT BY	CHECK BY	APPROVED BY	CUSTOMER :	DATE	
			PART NO : 54P-15106	REV NO.	
			ISSUE NO :	PAGE	4 - 1

2. WINDING CONFIGURATION :

STEP	WINDING	MARGIN TAPE	START-FINISH	COPPER WIRE	TURNS	LAYER TAPE	TUBE	METHOD
1	L		8 - 14	0.13 ϕ /12C	85	2Ts	#20	CLOSE
2	S1	2.0mm/~ \times 1T	4 - 10	0.23 ϕ	6.5	1T		CLOSE
3	S2		11 - 6	0.23 ϕ	4.5	3Ts		CLOSE, AFTER S1

NOTE:

3. ELECTRICAL CHARACTERISTICS :

PIN NO.	INDUCTANCE 1.0 KHz, 1.0Vrms	LEAKAGE INDUCTANCE KHz, Vrms	VOLTAGE RATIO(V) f= 20KHz INPUT 1 Vrms	DCR MAX AT 25°C
8 - 14	935.0uH \pm 5.0%			0.48 Ω
4 - 10			0.0752Vrms \pm 5.0%	180.0 m Ω
11 - 6			0.0525Vrms \pm 5.0%	134.0 m Ω

HI-POT TEST : (AT 1 mA, 2SEC)

PRI TO SEC 1800 VAC

PRI, SEC TO CORE. 900 VAC

INSULATION RESISTANCE: (AT DC 1500V)

PRI TO SEC 500 M Ω MIN.

PRI, SEC TO CORE 500 M Ω MIN.

INSULATION CLASS : CLASS E

使用溫度範圍 : -25°C~120°C

保存溫度範圍 : -40°C~85°C

REPORT	BY	CHECK	BY	APPROVED	BY	CUSTOMER :	DATE
						PART NO : 54P-15106	REV NO.
						ISSUE NO :	PAGE
							4 - 2

4. WINDING SEQUENCE :

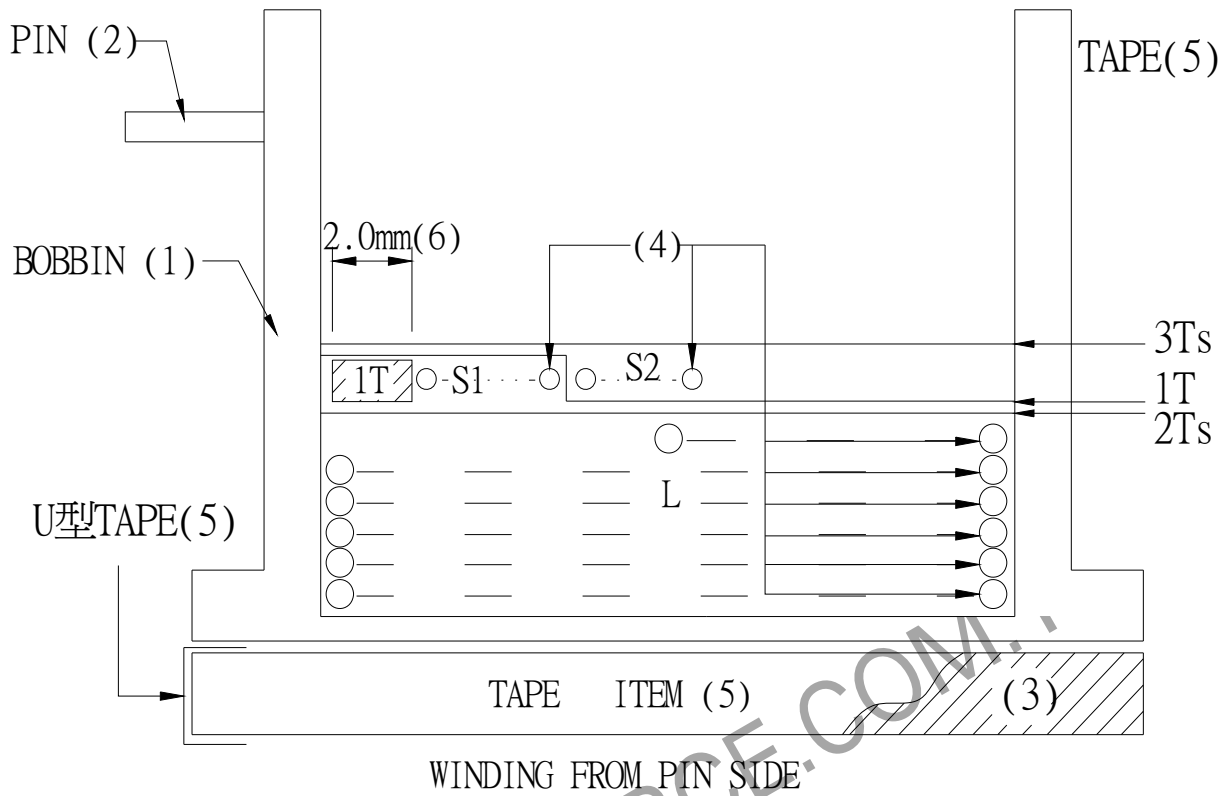

5. SCHEMATIC :

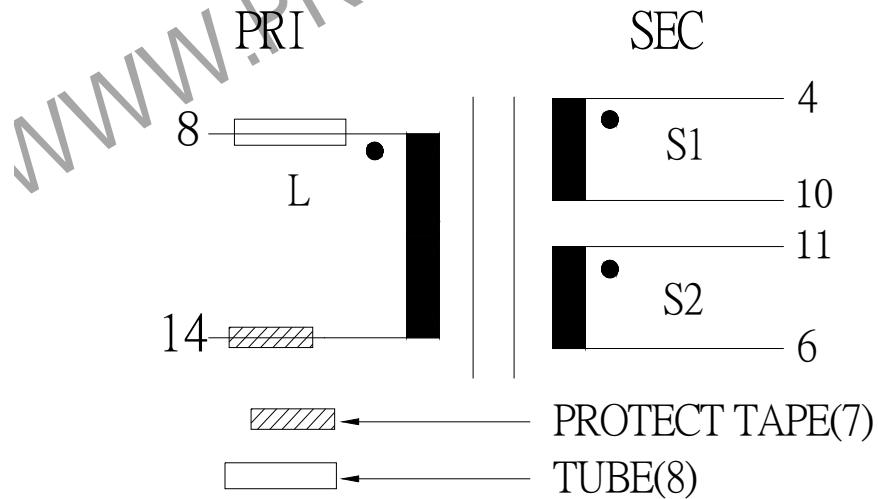

REPORT BY	CHECK BY	APPROVED BY	CUSTOMER :	DATE
			PART NO : 54P-15106	REV NO.
			ISSUE NO :	PAGE 4 - 3

6. MATERIAL LIST :

NO.	DESCRIPTION	ITEM	MATERIAL	LIST OF SAMPLE	UL NO.	MANUFACTURER
1	BOBBIN	(1)	PHENOLIC (PM9820) Thickness:0.30mm Min.	✓	E41429	SUMITOMO
2	PIN	(2)	TINNED COPPER WIRE φ 0.6	✓		WELL FORE
3	CORE	(3)	FERRITE CORE PQ20/20 TP4 CORE GAP :0.79mm	✓		TDG
4	COPPER WIRE	(4)	POLYURETHANE (1UEW) MW75-C TYPU-130	✓	E197768	HENG YA
5	MYLAR TAPE	(5)	POLYESTER FILM #1318-1 Y	✓	E17385	3M
6	MARGIN TAPE	(6)	COMPOSITE FILM #44D-A	✓	E17385	3M
7	PROTECT TAPE	(7)	COMPOSITE FILM #44-A	✓	E17385	3M
8	TUBE	(8)	TEFLON TUBE TFL	✓	E156256	GREAT HOLDING
9	EPOXY		6020H	✓	E229633	WELLS
10	VARNISH		TVB2180T	✓	E83702	KYOCERA

REPORT BY	CHECK BY	APPROVED BY	CUSTOMER :	DATE	
			PART NO : 54P-15106	REV NO.	
			ISSUE NO :	PAGE	4 - 4