

1.MECHANICAL & ASSEMBLY:

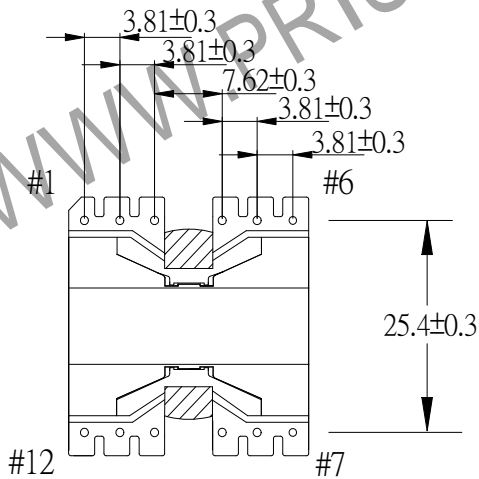
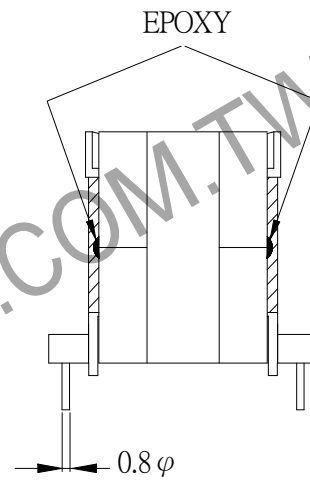
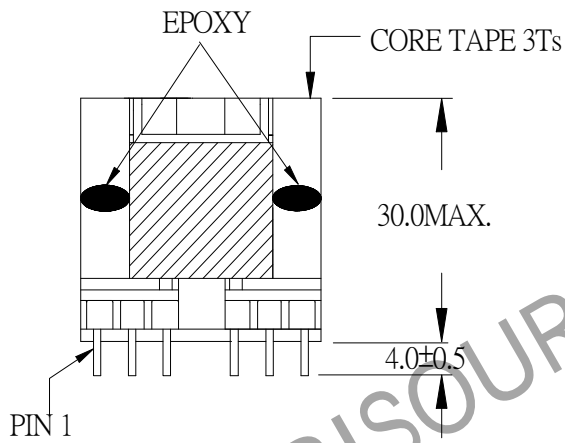
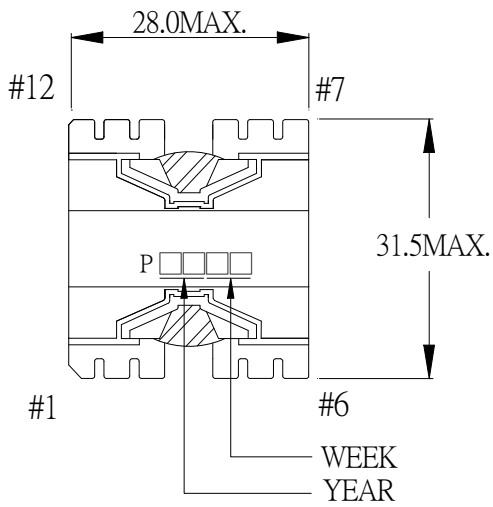

NOTE:

1. EPOXY FIXED BETWEEN CORE & CORE (TTL:4 POINTS)
2. EPOXY FIXED TOP OF BOBBIN & CORE (ONE POINT)

UNIT : mm

REPORT BY	CHECK BY	APPROVED BY	CUSTOMER :	DATE
			PART NO : 54P-15098	REV NO.
			ISSUE NO :	PAGE
				4 - 1

2. WINDING CONFIGURATION :

STEP	WINDING	MARGIN TAPE	START-FINISH	COPPER WIRE	TURNS	LAYER TAPE	METHOD
1		#44D-A 13.0mm				4Ts	
2	N		2,3 - 4,5	0.12/80φ×2	8	2Ts	CLOSE

NOTE:

3. ELECTRICAL CHARACTERISTICS :

PIN NO.	INDUCTANCE 1.0 KHz, 1.0Vrms	LEAKAGE INDUCTANCE KHz, mVrms	VOLTAGE RATIO(V) f= 20KHz	DCR MAX AT 25°C
2,3 - 4,5	5.5 ~ 6.4uH			6.5 mΩ

HI -POT TEST : (AT 1 mA, 2 SEC.)

PRI TO CORE 1200VAC

INSULATION RESISTANCE: (AT DC 1000V)

PRI TO CORE 100 MΩ MIN.

REPORT BY	CHECK BY	APPROVED BY	CUSTOMER :	DATE	
			PART NO : 54P-15098	REV NO. NO.	
			ISSUE NO :	PAGE	4 - 2

4. WINDING SEQUENCE:

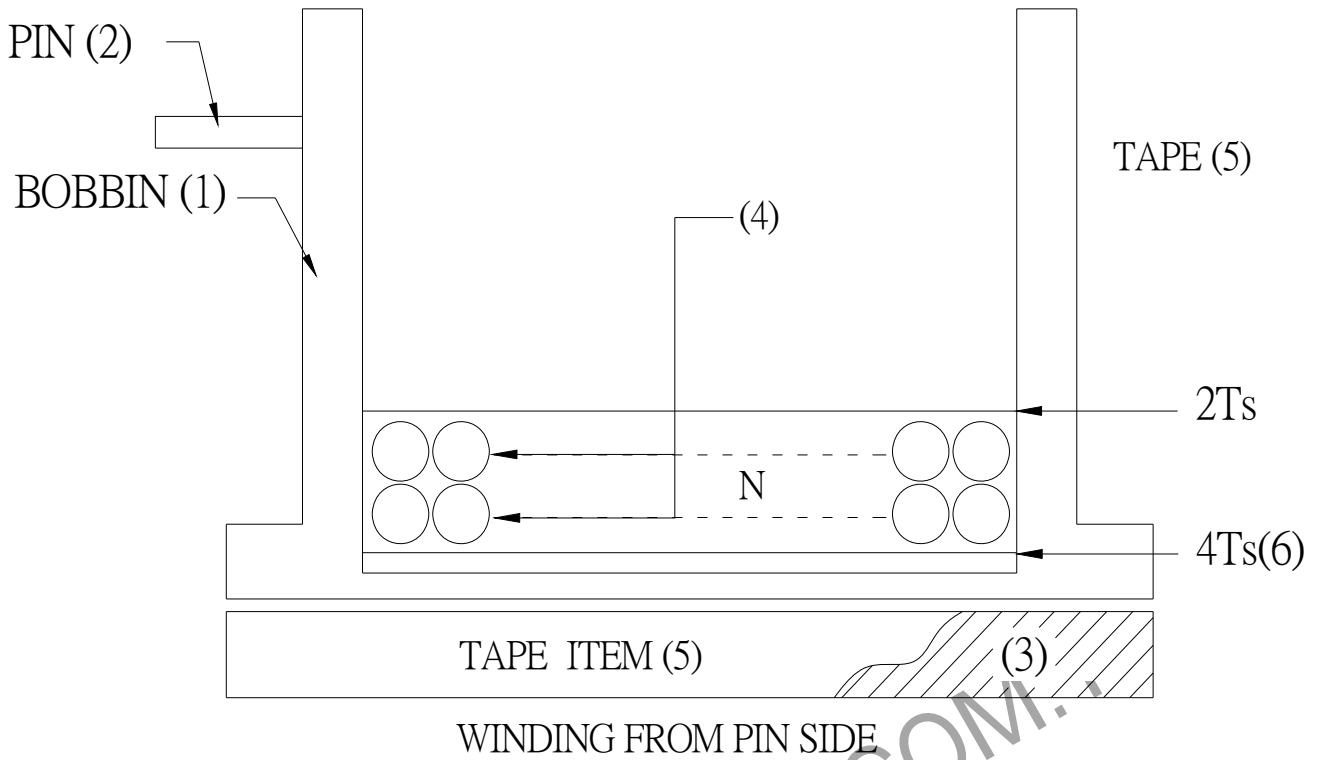

5. SCHEMATIC:

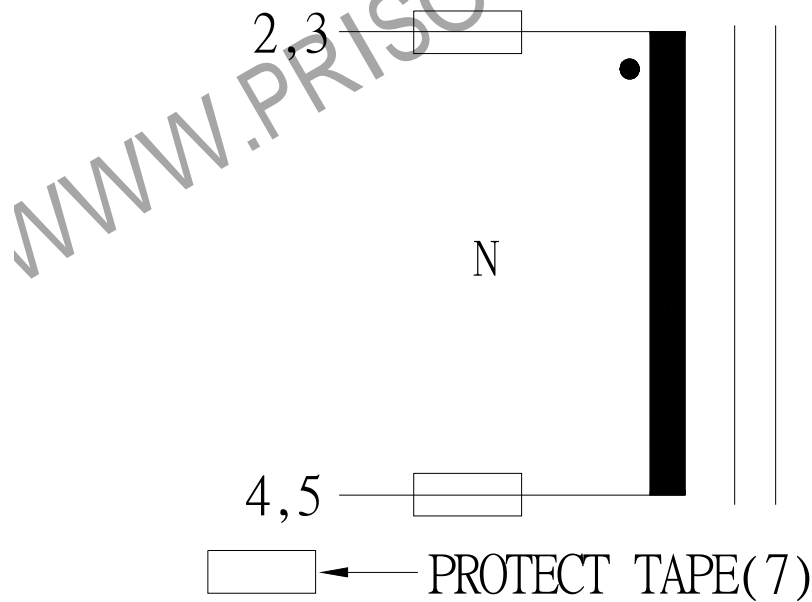

REPORT BY	CHECK	APPROVED BY	CUSTOMER :	DATE	
			PART NO : 54P-15098	REV NO.	
			ISSUE NO :	PAGE	4 - 3

6 . MATERIALS LIST :

NO	DESCRIPTION	ITEM	MATERIAL	LIST OF SAMPLE	UL NO.	MANUFACTURE
1	BOBBIN	(1)	PHENOLIC (PM9820) Thickness:0.30 mm Min.	√	E41429	SUMITOMO
2	PIN	(2)	TINNED C.P WIRE 0.8 φ	√		WELL FORE
3	CORE	(3)	FERRITE CORE PQ2625 TP4	√		TDG
4	COPPER WIRE	(4)	POLYURETHANE (2UEW) TYPU-130 MW75-C	√	E197768	HENG YA
5	MYLAR TAPE	(5)	POLYESTER FILM #1318-1(Y)	√	E17385	3M
6	MARGIN TAPE	(6)	COMPOSITE FILM #44D-A	√	E17385	3M
7	PROTECT TAPE	(7)	COMPOSITE FILM #44-A	√	E17385	3M
8	EPOXY		6020H	√	E229633	WELLS
9	VARNISH		TVB2180T	√	E83702	KYOCERA
REPORT BY	CHECK BY	APPROVED BY	CUSTOMER :		DATE	
			PART NO : 54P-15098		REV NO.	
			ISSUE NO :		PAGE	4 - 4