

# 1. MECHANICAL & ASSEMBLY :

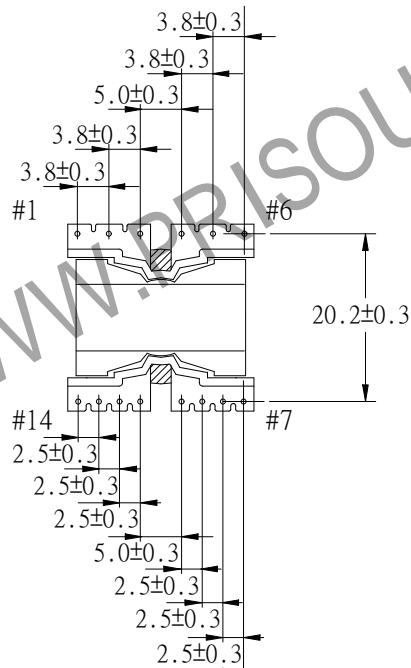
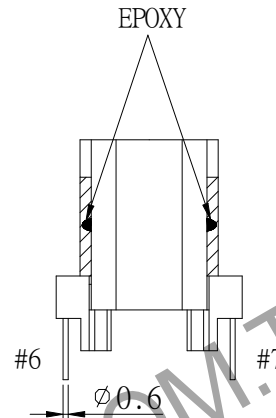
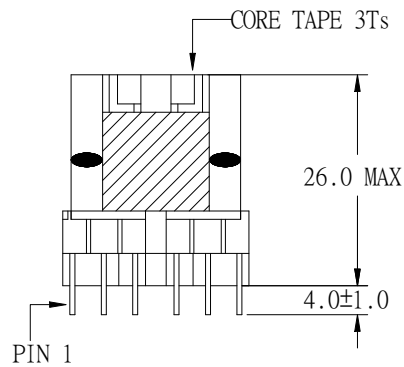
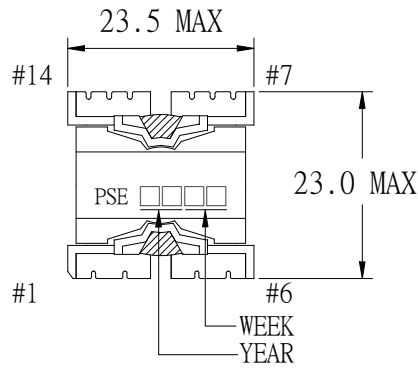

## NOTE:

1. EPOXY FIXED BETWEEN CORE & CORE (TTL:4 POINTS) EPOXY FIXED TOP OF BOBBIN & CORE.(ONE POINT).

UNIT: inch

REPORT BY	CHECK BY	APPROVED BY	CUSTOMER :	DATE	
			PART NO : 54P-15004	REV NO.	
			ISSUE NO :	PAGE	4 - 1

## 2. WINDING CONFIGURATION :

STEP	WINDING	MARGIN TAPE	START-FINISH	COPPER WIRE	TURNS	LAYER TAPE	TUBE	METHOD
1	P1		3 - 4	φ0.4×2	12	3Ts	#18	CLOSE
2	S1		9 - 12	φ0.37	28	1T		CLOSE
3	S2		10 - 11	φ0.37	28	3Ts		CLOSE
4	P2		3 - 4	φ0.4×2	12	1T	#18	CLOSE
5	P3		5 - 6	φ0.4×2	12	1T		CLOSE
6	P4		1 - 2	φ0.2×2	7	3Ts		SPACE

NOTE: P1,S1,S2,P2,P4 WITH 1PC CROSS TAPE : 3M SUPER #10

## 3. ELECTRICAL CHARACTERISTICS :

PIN NO.	INDUCTANCE 1 KHz, 1.0 Vrms	LEAKAGE INDUCTANCE 1.0KHz, 1.0Vrms	VOLTAGE RATIO(V) F= 20KHz	DCR.MAX AT 25°C
9 - 12		SHORT	INPVT 1Vrms	235.0 mΩ
10 - 11		SHORT	1.0000 Vrms ± 3%	255.0 mΩ
3 - 4	388uH MIN	0.8uH MAX	0.4285 Vrms ± 4%	24.0 mΩ
1 - 2			0.2500 Vrms ± 4%	144.0 mΩ
5 - 6			0.4285 Vrms ± 4%	56.0 mΩ

HI-POT TEST :( AT 2 mA , 2 SEC. )

PRI.	TO	SEC.	600 VAC
PRI.	TO	CORE.	600 VAC
SEC.	TO	CORE.	600 VAC
PRI.	TO	PRI.	600 VAC

INSULATION RESISTANCE:(AT DC 500V)

PRI.	TO	SEC.	100 MΩ MIN.
PRI.	TO	CORE.	100 MΩ MIN.
SEC.	TO	CORE.	100 MΩ MIN.

REPORT BY	CHECK BY	APPROVED BY	CUSTOMER :	DATE	
			PART NO : 54P-15004	REV NO.	
			ISSUE NO :	PAGE	4 - 2

#### 4. WINDING SEQUENCE:

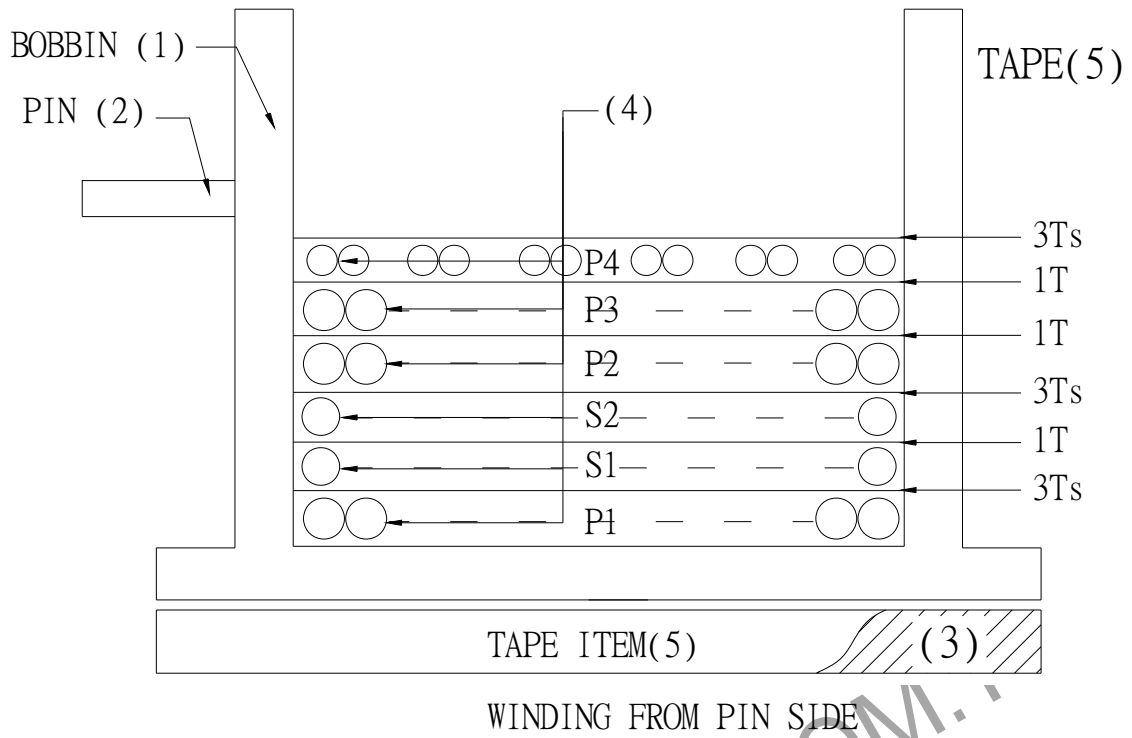

#### 5. SCHEMATIC:

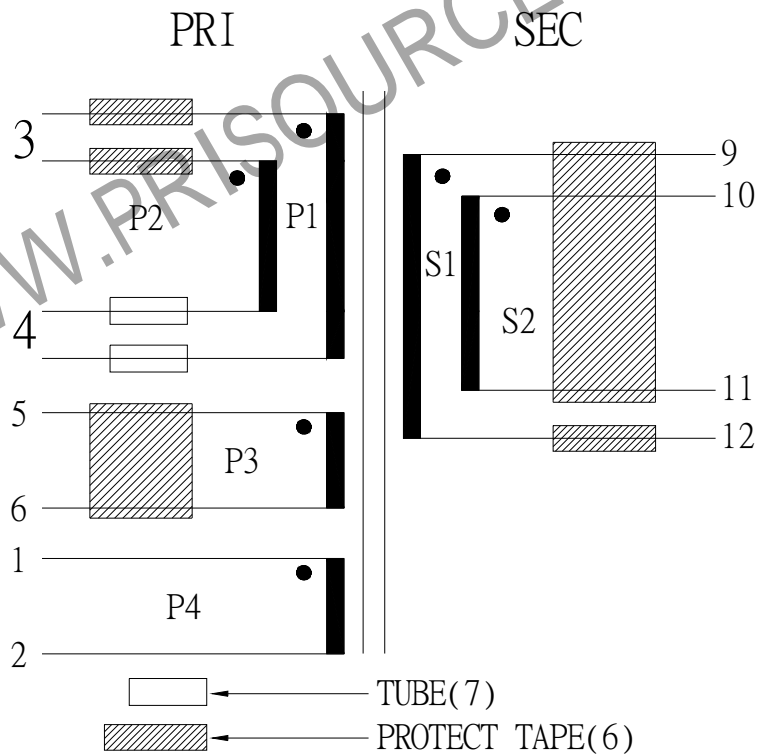

REPORT BY	CHECK BY	APPROVED BY	CUSTOMER :	DATE	
			PART NO : 54P-15004	REV NO.	
			ISSUE NO :	PAGE	4 - 3

## 6 . MATERIAL LIST :

NO	DESCRIPTION	ITEM	MATERIAL	LIST OF SAMPLE	UL NO.	MANUFACTURE
1	BOBBIN	(1)	PHENOLIC(PM9820) Thickness : 0.30mm MIN	√	E41429	SUMITOMO
2	PIN	(2)	TINNED COPPER WIRE 0.6 φ	√		
3	CORE	(3)	FERRITE PQ20/20 (NO GAP) DMR95	√		DMEGC
4	COPPER WIRE	(4)	POLYURETHANE (2UEW) TYPU-130 MW75-C	√	E197768	HENG YA
5	MYLAR TAPE	(5)	POLYESTER FILM #1318-1(Y)	√	E17385	3M
6	PROTECT TAPE	(6)	COMPOSITE FILM SUPER #10 w=5.0	√	E17385	3M
7	TUBE	(7)	TEFLON TUBE TFL	√	E156256	GREAT HOLDING
8	EPOXY		6020H	√	E229633	WELLS
9	VARNISH		TVB2180T	√	E83702	KYOCERA

REPORT BY	CHECK BY	APPROVED BY	CUSTOMER :	DATE
			PART NO : 54P-15004	REV NO.
			ISSUE NO :	PAGE 4 - 4