

1. MECHANICAL & ASSEMBLY :

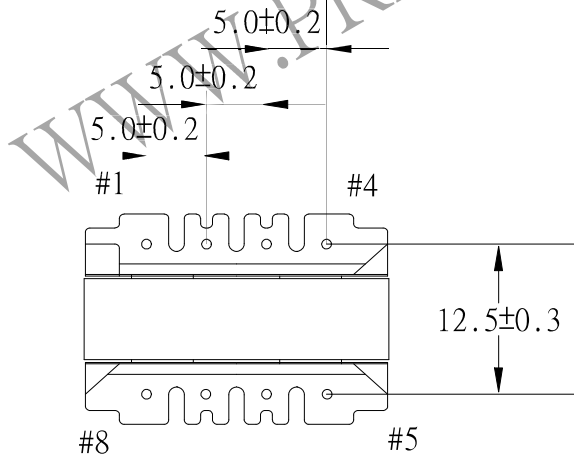
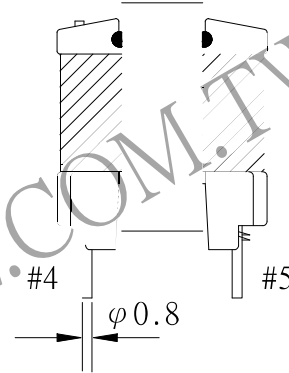
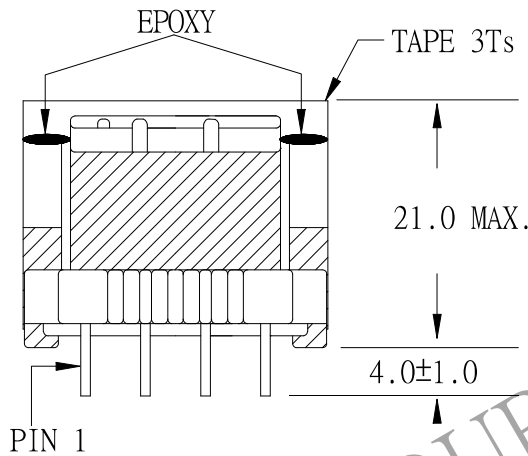
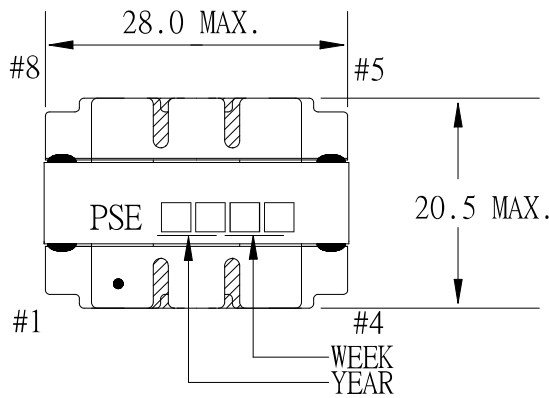

NOTE:

1. EPOXY FIXED BETWEEN CORE & CORE (TTL:4 POINTS) EPOXY FIXED TOP OF BOBBIN & CORE.(ONE POINT AT PIN1-4 SIDE).

UNIT : m / m

REPORT BY	CHECK BY	APPROVED BY	CUSTOMER :	DATE	
			PART NO : 54P-13044	REV NO.	
			ISSUE NO :	PAGE	4 - 1

2. WINDING CONFIGURATION :

STEP	WINDING	MARGIN TAPE	START-FINISH	COPPER WIRE	TURNS	TUBE	LAYER TAPE	METHOD
1	P1-1	~3.0mm×1T	1 - A	0.10φ	108	#24	1T/1T	CLOSE
2	S1	~1.5mm×5Ts	7 - 8	TEX-E 0.20φ	69	#24	1T	CLOSE
3	P1-2	~3.0mm×1T	A - 2	0.10φ	108	#24	1T/1T	CLOSE
4	S2	~1.5mm×5Ts	5 - 6	TEX-E 0.20φ	69	#24	1T	CLOSE
5	P2	~3.0mm×1T	3 - 4	0.10φ×2	18		1T	CLOSE

NOTE: A WIRE NEED TO RETROFLEX PIN SIDE AND THEN IT COVERED WITH LAYER TAPE 2Ts.

3. ELECTRICAL CHARACTERISTICS :

PIN NO.	INDUCTANCE 1 KHz, 1Vrms	LEAKAGE INDUCTANCE KHz, Vrms	VOLTAGE RATIO(V) f= 20KHz INPUT 1V	DCR MAX. AT 25°C
1 - 2	9.331mH±10%			26.0 Ω
3 - 4			0.0833Vrms±7.0%	1.5 Ω
7 - 8			0.3190Vrms±4.0%	2.0 Ω
5 - 6			0.3190Vrms±4.0%	2.5 Ω

HI-POT TEST : (AT 1 mA, 2 SEC)

PRI	TO	SEC	3600VAC
PRI	TO	CORE	1800VAC
SEC	TO	CORE	1800VAC

INSULATION RESISTANCE: (AT DC 1500V)

PRI	TO	SEC	100 MΩ	MIN.
PRI	TO	CORE	100 MΩ	MIN.
SEC	TO	CORE	100 MΩ	MIN.

REPORT BY	CHECK BY	APPROVED BY	CUSTOMER :	DATE	
			PART NO : 54P-13044	REV NO.	
			ISSUE NO :	PAGE	4 - 2

4. WINDING SEQUENCE:

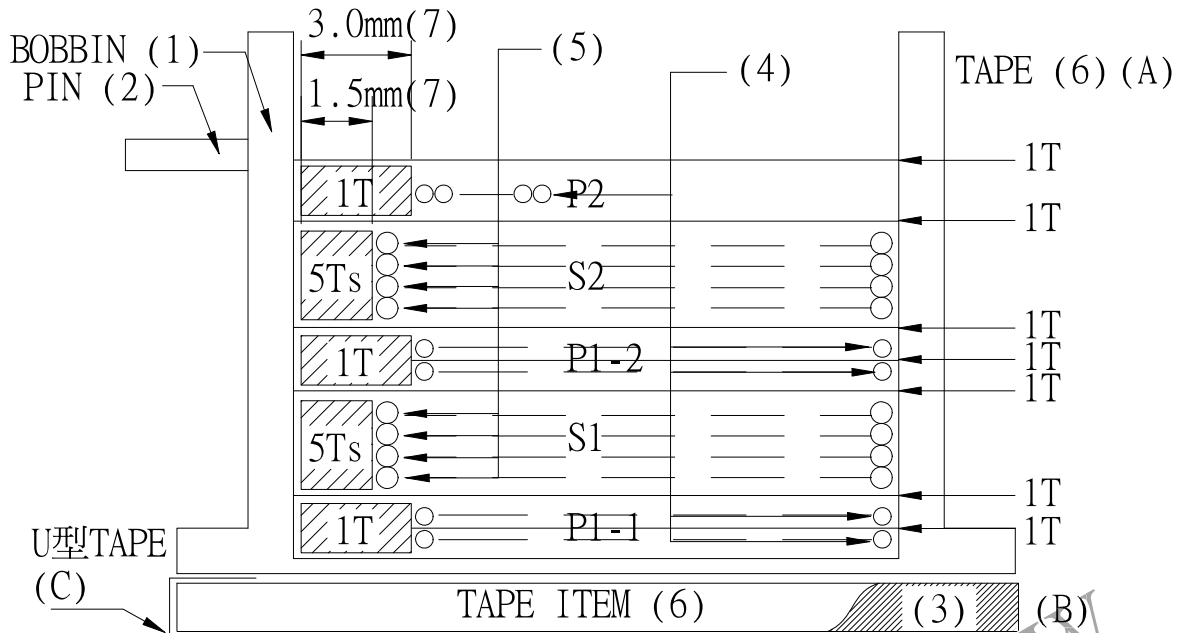

P1-1, S1, S2, P2 WONDING FROM PIN SIDE
P1-2 WONDING FROM TOP SIDE

5. SCHEMATIC:

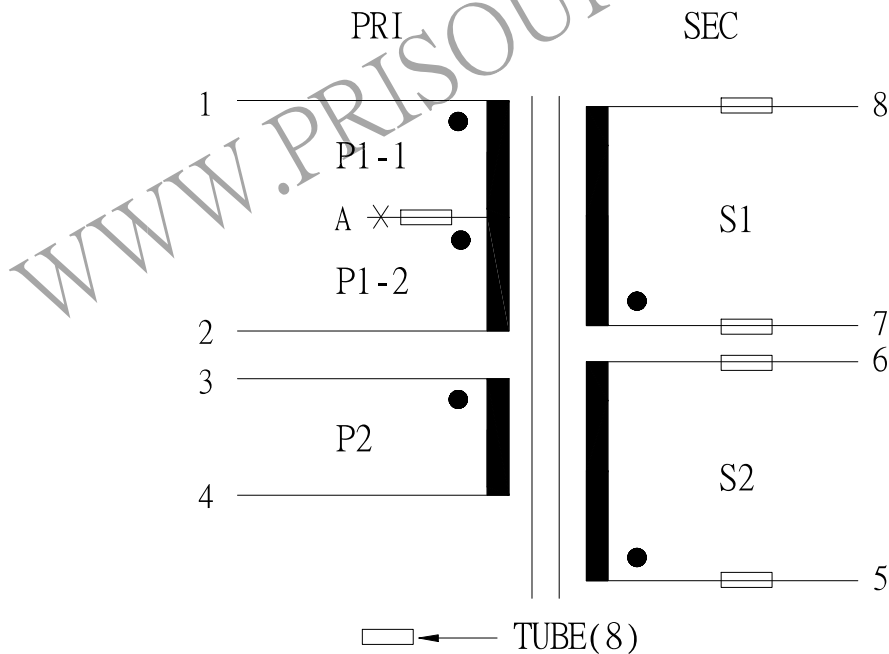

REPORT BY	CHECK BY	APPROVED	CUSTOMER :	DATE
			PART NO : 54P-13044	REV NO.
			ISSUE NO :	PAGE
				4 - 3