

# 1. MECHANICAL & ASSEMBLY :

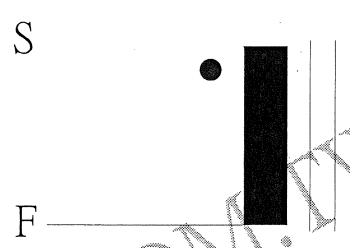
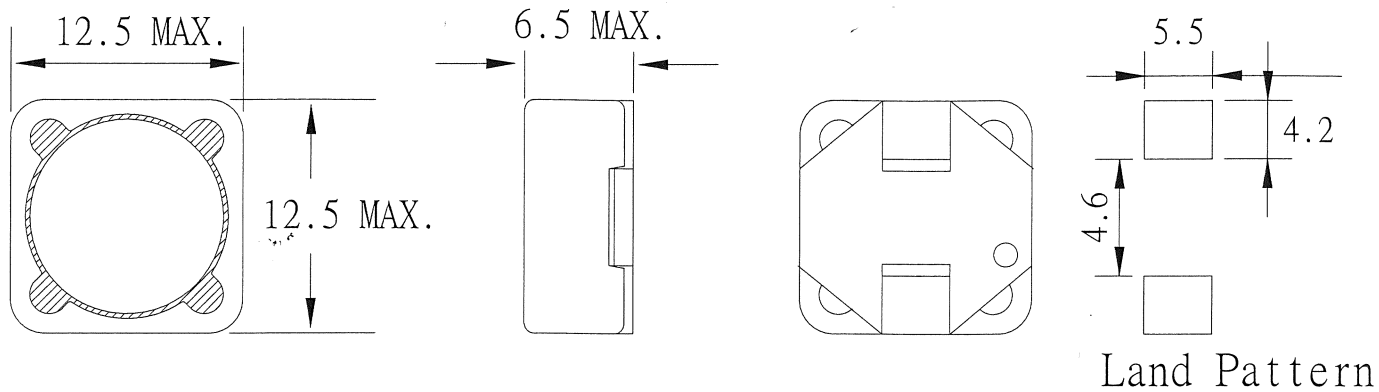

UNIT : m/m

# 2. WINDING CONFIGURATION:

STEP	WINDING	MARGIN TAPE	START-FINISH	COPPER WIRE	TURN	LAYER TAPE	METHOD
1		~	S - F	0.20	116.5Ts		CLOSE

# 3. ELECTRICAL CHARACTERISTICS:

PIN NO.	INDUCTANCE 10 KHz, 0.25 V	INDUCTANCE 10KHz, 0.25Vrms+DC0.3A	VOLTAGE RATIO(V)	DCR(MAX.) AT 25°C
S - F	1.0 mH ±20%	1.0 mH ±20%		1.78 OHM